



**CORONAS GIRATORIAS
SLEWING BEARINGS**



**CATÁLOGO TÉCNICO GENERAL
GENERAL TECHNICAL CATALOGUE**



01.07.12

TIPOLOGÍAS/SERIES OVERVIEW

ZK

Dentada interior / Int. toothed



NK

No dentada / Untoothed



EBL SERIES

Dentada exterior / Ext. toothed



EBL.20 S
EBL.20 P
EBL.30 S
EBL.30 P

ZBL SERIES

Dentada interior / Int. toothed



ZBL.20 S
ZBL.20 P
ZBL.30 S
ZBL.30 P

NBL SERIES

No dentada / Untoothed



NBL.20 S
NBL.20 P
NBL.30 S
NBL.30 P

EB1 SERIES

Dentada exterior / Ext. toothed

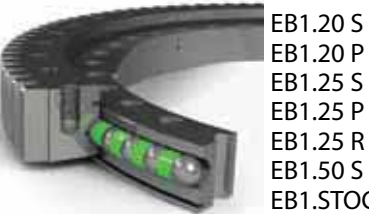

EB1.20 S
EB1.20 P
EB1.25 S
EB1.25 P
EB1.25 R
EB1.50 S
EB1.STOCK

ZB1 SERIES

Dentada interior / Int. toothed



ZB1.20 S
ZB1.20 P
ZB1.25 S
ZB1.25 P
ZB1.25 R
ZB1.50 S
ZB1.STOCK

NB1 SERIES

No dentada / Untoothed



NB1.20 S
NB1.20 P
NB1.25 S
NB1.25 P
NB1.STOCK

EB2 SERIES

Dentada exterior / Ext. toothed



ZB2 SERIES

Dentada interior / Int. toothed



ER1 SERIES

Dentada exterior / Ext. toothed



ER1.14 S
ER1.14 PR
ER1.16 S
ER1.20/30
ER1.36/50

ZR1 SERIES

Dentada interior / Int. toothed



ZR1.14 S
ZR1.14 PR
ZR1.16 S
ZR1.20/25
ZR1.30/50

NR1 SERIES

No dentada / Untoothed



NR1.14 S
NR1.14 PR
NR1.16 S

ER3 SERIES

Dentada exterior / Ext. toothed



ER3.20/25
ER3.32/40

ZR3 SERIES

Dentada interior / Int. toothed



ZR3.20/25
ZR3.32/40

CRBH, RB, YRT

Rodamientos de precisión
Precision bearings



RB, RE
RU, CRBH
CRBC, SX
YRT, YRTS
ZKLF

PROGRAMA GENERAL DE VENTAS - GENERAL SALES PROGRAM



RODAMIENTOS Y COMPONENTES *
BEARINGS AND COMPONENTS *



SOPORTES AUTOALINEANTES *
SELF-ALIGNING BEARING UNITS *



RÓTULAS - CABEZAS DE ARTICULACIÓN - HORQUILLAS *
SPHERICAL PLAIN BEARINGS - ROD ENDS - CLEVISES *



CASQUILLOS*
BUSHES *



CORONAS GIRATORIAS *
SLEWING BEARINGS *



ELECTRICAL MOTORS
STANDARD
RODAMIENTOS PARA APLICACIONES "BAJA RUMOROSIDAD" *
BEARINGS FOR "LOW NOISE" APPLICATIONS *



RODAMIENTOS DE AGUJAS *
NEEDLE BEARINGS *

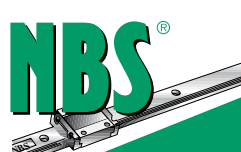

COMPONENTES PARA SISTEMAS LINEALES*
COMPONENTS FOR LINEAR MOTION *

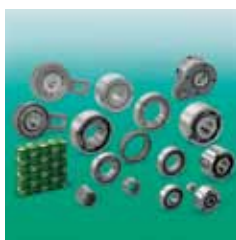

RUEDAS LIBRES *
FREE WHEELS *

Disponibile un stock amplio y completo de rodamientos con entrega inmediata.
Wide and complete assortment of bearings with prompt delivery.



RODAMIENTOS SKF - FAG
SKF - FAG BEARINGS



CATÁLOGO TÉCNICO GENERAL
GENERAL TECHNICAL CATALOGUE

Distribuidor / Distributor



PAÍSES DONDE ESTAMOS PRESENTES

COUNTRIES WHERE WE ARE REPRESENTED

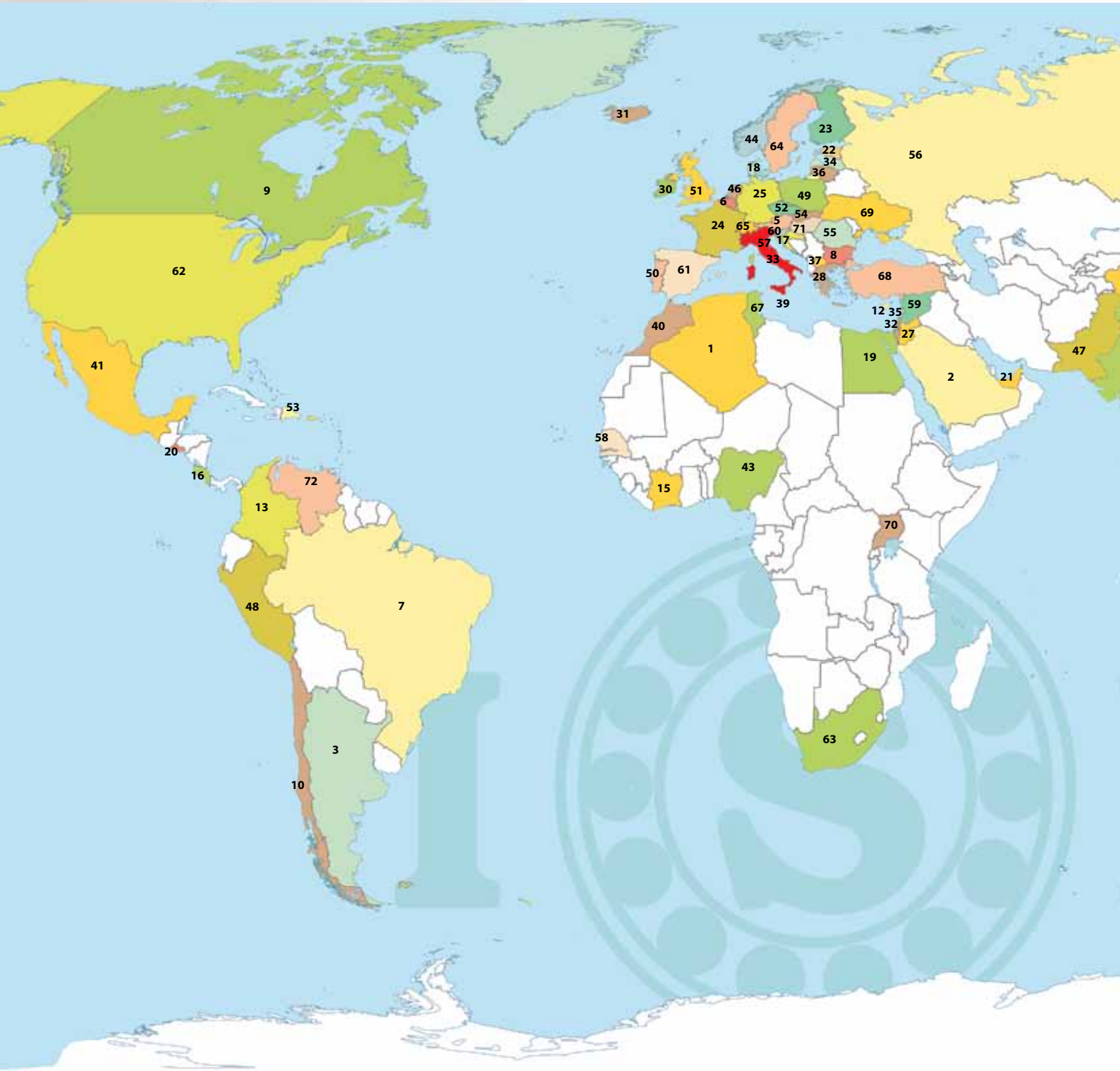

***hora legal (período de marzo a octubre en Italia)**

*summer time (from March to October in Italy)

hora solar (-1)

standard time (-1)

para las capitales con el horario indicado en rojo no existe una hora legal

time is indicated in red for capitals with no daylight saving time (DST)

PRODUCCIÓN

Todos los productos **ISB®** son fabricados exclusivamente por empresas que cuentan con Sistema de Calidad certificado según las normas **UNI EN ISO 9001:2008**.



PRODUCTION

All **ISB®** products are manufactured exclusively by companies with **UNI EN ISO 9001:2008** certified Quality System.

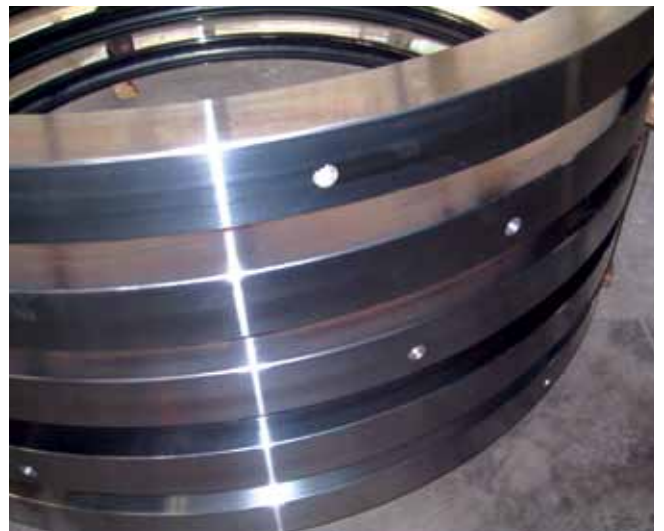

PRODUCCIÓN

Todos los productos **ISB®** son fabricados exclusivamente por empresas que cuentan con Sistema de Calidad certificado según las normas **UNI EN ISO 9001:2008**.



PRODUCTION

All **ISB®** products are manufactured exclusively by companies with **UNI EN ISO 9001:2008** certified Quality System.

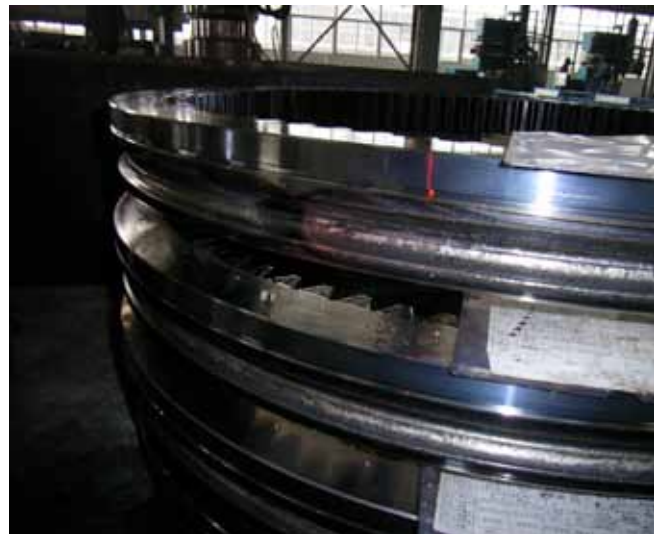

CONTROL DE CALIDAD EN ITALIA

... centro de control de calidad en nuestra sede en ITALIA.

... un staff de Ingenieros técnicos de la Calidad, a su servicio.



CONTROL DE CALIDAD EN ASIA

... laboratorios externos especializados y dotados de modernos instrumentos de medición y control realizan una serie de comprobaciones adicionales.

Laboratorio Control Calidad.



ITALY QUALITY CONTROL

... a quality control centre is located in our headquarter in ITALY.

... our staff of technical engineers at your service, for Quality.



ASIA QUALITY CONTROL

... an additional series of tests are conducted by specialised third party Laboratories using the latest instruments.

Quality Control Laboratory.



GAMA DE PRODUCTOS ISB - PRODUCTS RANGE ISB



**RODAMIENTOS
BEARINGS**



**RODAMIENTOS PARA
APLICACIONES "BAJA
RUMOROSIDAD"
BEARINGS FOR "LOW NOISE"
APPLICATIONS**



**SOPORTES AUTOALINEANTES
SELF-ALIGNING BEARING UNITS**



**RÓTULAS
CABEZAS DE ARTICULACIÓN -
HORQUILLAS
SPHERICAL PLAIN BEARINGS
ROD ENDS - CLEVISES**



**CASQUILLOS
BUSHES**



**RODAMIENTOS DE GRANDES
DIMENSIONES
LARGE BEARINGS**



**CORONAS GIRATORIAS
SLEWING BEARINGS**



**RODAMIENTOS DE BOLAS EN
MATERIALES POLIMÉRICOS
POLYMERIC BALL BEARINGS**



**RODAMIENTOS BONDERIZADOS
PARA ALTAS TEMPERATURAS
BONDERIZED BEARINGS FOR
HIGH TEMPERATURES**



**BOLAS TRANSPORTADORAS
BOLAS DE PRECISIÓN
RODILLOS Y AGUJAS DE
PRECISIÓN
BALL TRANSFER UNITS
PRECISION BALLS
PRECISION ROLLERS
AND NEEDLES**



**OBTURACIONES METÁLICAS
PARA RODAMIENTOS
METALLIC SEALS FOR
BEARINGS**



**PRODUCTOS DE ACERO
INOXIDABLE
STAINLESS STEEL PRODUCTS**

La gama de productos ISB® está en continuo desarrollo y será en breve ampliada con la incorporación de nuevas referencias.
The ISB® range is continuously in evolution and shortly will be widened by the addition of new items.



ÍNDICE

PARTE 1	
APLICACIONES Y TECNOLOGÍA DE LAS CORONAS GIRATORIAS	
Sectores de aplicación	pág. 13
Componentes de la corona giratoria	» 14
Materiales de los aros	» 23
Temple por inducción de los caminos de rodadura	» 26
Temple por inducción de los dientes	» 28
Tipología de juegos	» 29
Sistemas de protección superficial	» 30
PARTE 2	
ELECCIÓN DE LA CORONA GIRATORIA	
Introducción	» 35
Capacidad estática	» 36
Factor de seguridad estático	» 37
Resistencia de los bulones de fijación	» 41
Utilización del diagrama de carga	» 42
Verificación en presencia de carga radial	» 44
Cálculo de la vida útil a fatiga	» 46
Resistencia del dentado	» 47
Fricción y lubricación	» 49
PARTE 3	
CATÁLOGO GENERAL DE LAS CORONAS GIRATORIAS	
Tipologías	» 53
Codificación	» 54
Coronas giratorias serie ligera de una hilera de bolas ZK - NK	» 56
Coronas giratorias con bridas de una hilera de bolas, dentado exterior EBL.20 S - EBL.20P - EBL.30 S - EBL.30 P	» 57
Coronas giratorias con bridas de una hilera de bolas, dentado interior ZBL.20 S - ZBL.20P - ZBL.30 S - ZBL.30 P	» 61
Coronas giratorias con bridas de una hilera de bolas, sin dentado NBL.20 S - NBL.20P - NBL.30 S - NBL.30 P	» 67
Coronas giratorias con bridas de una hilera de bolas, dentado exterior EB1.20 S - EB1.20P - EB1.25 S - EB1.25 P EB1.25 R - EB1.50 S - EB1 STOCK	» 73
Coronas giratorias de una hilera de bolas, dentado interior ZB1.20 S - ZB1.20P - ZB1.25 S - ZB1.25 P ZB1.25 R - ZB1.50 S - ZB1 STOCK	» 79

INDEX

PART 1	
APPLICATIONS & TECHNOLOGY OF SLEWING BEARINGS	
<i>Applicazion fields</i>	<i>pag. 13</i>
<i>Slewing bearing components</i>	» 14
<i>Rings material</i>	» 23
<i>Raceway induction hardening</i>	» 26
<i>Gear induction hardening</i>	» 28
<i>Clereances types</i>	» 29
<i>Surface protection systems</i>	» 30
PART 2	
SLEWING BEARING SELECTION	
<i>Introduction</i>	» 35
<i>Static capacity</i>	» 36
<i>Static safety factor</i>	» 37
<i>Bolts resistance</i>	» 41
<i>Use of load diagram</i>	» 42
<i>Verification in presence of radial load</i>	» 44
<i>Rating life calculation</i>	» 46
<i>Gear resistance</i>	» 47
<i>Friction & lubrication</i>	» 49
PART 3	
GENERAL CATALOGUE OF SLEWING BEARINGS	
<i>Overview</i>	» 53
<i>Designation</i>	» 54
<i>Light series one row ball bearings ZK - NK</i>	» 56
<i>One row ball flanged bearing, external toothed EBL.20 S - EBL.20P - EBL.30 S - EBL.30 P</i>	» 57
<i>One row ball flanged bearing, internal toothed ZBL.20 S - ZBL.20P - ZBL.30 S - ZBL.30 P</i>	» 61
<i>One row ball flanged bearing, untoothed NBL.20 S - NBL.20P - NBL.30 S - NBL.30 P</i>	» 67
<i>One row ball flanged bearing, external toothed EB1.20 S - EB1.20P - EB1.25 S - EB1.25 P EB1.25 R - EB1.50 S - EB1 STOCK</i>	» 73
<i>One row ball bearing, internal toothed ZB1.20 S - ZB1.20P - ZB1.25 S - ZB1.25 P ZB1.25 R - ZB1.50 S - ZB1 STOCK</i>	» 79

Coronas giratorias de una hilera de bolas, sin dentado »	101	<i>One row ball bearing, untoothed</i>	» 101
NB1.25 S - NB1.25 P - NB1.25 R - NB1 STOCK		NB1.25 S - NB1.25 P - NB1.25 R - NB1 STOCK	
Coronas giratorias de dos hileras de bolas, dentado exterior »	111	<i>Double row ball bearing, external toothed</i>	» 111
EB2		EB2	
Coronas giratorias de dos hileras de bolas, dentado interior »	115	<i>Double row ball bearing, internal toothed</i>	» 115
ZB2		ZB2	
Coronas giratorias de una hilera de rodillos cruzados, dentado exterior »	119	<i>One row crossed roller bearing, external toothed</i>	» 119
ER1.14 S - ER1.14 PR - ER1.16 S ER1.16/25 - ER1.36/50		ER1.14 S - ER1.14 PR - ER1.16 S ER1.16/25 - ER1.36/50	
Coronas giratorias de una hilera de rodillos cruzados, dentado interior »	125	<i>One row crossed roller bearing, internal toothed</i>	» 125
ZR1.14 S - ZR1.14 PR - ZR1.16 S ZR1.16/25 - ZR1.30/50		ZR1.14 S - ZR1.14 PR - ZR1.16 S ZR1.16/25 - ZR1.30/50	
Coronas giratorias de una hilera de rodillos cruzados, sin dentado »	131	<i>One row crossed roller bearing, untoothed</i>	» 131
NB1.14 S - NB1.14 PR - NB1.16 S		NB1.14 S - NB1.14 PR - NB1.16 S	
Coronas giratorias de tres hileras de rodillos, dentado exterior »	135	<i>Triple row roller bearing, external toothed</i>	» 135
ER3.20/25 - ER3.32/40		ER3.20/25 - ER3.32/40	
Coronas giratorias de tres hileras de rodillos, dentado interior »	139	<i>Triple row roller bearing, internal toothed</i>	» 139
ZR3.20/25 - ZR3.32/40		ZR3.20/25 - ZR3.32/40	
Serie de rodillos cruzados para rotación de precisión »	143	<i>Crossed roller series for precision rotation</i>	» 143
RB - RE - RU - CRBH - CRBC - CRB - SX		RB - RE - RU - CRBH - CRBC - CRB - SX	
Rodamientos de precisión YRT, para mesas giratorias »	153	<i>Tunable precision bearing YRT</i>	» 153
YRT - YRTS - ZKLDF		YRT - YRTS - ZKLDF	
PARTE 4		PART 4	
INSTALACIÓN Y MANTENIMIENTO »	159	INSTALLATION AND MAINTENANCE »	159
Control planeidad »	160	Flatness check »	160
Apriete de la tornillería »	161	Bolts tightening »	161
Operaciones preliminares »	162	Preliminary operations »	162
Montaje »	163	Installation »	163
Lubricación de los caminos de rodadura »	165	Raceway lubrication »	165
Lubricación del dentado »	166	Gear lubrication »	166
Manipulación y almacenaje »	167	Handling and storage »	167
PARTE 5		PART 5	
TABLAS DE EQUIVALENCIA		CROSSED REFERENCE TABLES	
DE CORONAS GIRATORIAS »	169	FOR SLEWING BEARINGS »	169
Listado de coronas giratorias para excavadoras »	170	List of slewing ring for excavator »	170
Listado de equivalencia de los coronas giratorias»	171	Slewing bearing cross reference list »	171
Módulo de solicitud cliente »	184	Customer request module »	184



PARTE 1 - APLICACIONES Y TECNOLOGÍA DE LAS CORONAS GIRATORIAS

PART 1 - APPLICATIONS & TECHNOLOGY OF SLEW BEARINGS

SECTORES DE APLICACIÓN DE LAS CORONAS GIRATORIAS SLEW BEARING APPLICATION FIELDS

Las coronas giratorias son necesarias cuando en el interior de una máquina o de una aplicación, una parte estructural tiene que girar respecto a otra parte, sobre un único eje, garantizando el vínculo entre dichas partes.

La corona, con la rigidez máxima aportada por su propio diseño, tiene que soportar y transmitir las cargas operativas de la estructura a la que está unida y debe garantizar además el grado de precisión requerido para la aplicación en cuestión, el respeto de los parámetros de funcionamiento y el ciclo de duración de vida necesario. Resulta evidente por lo tanto cómo el rodamiento constituya un componente fundamental y cómo su selección deba responder a atentos estudios técnicos. Italcuscinetti SpA ofrece asistencia para la elección del rodamiento ideal para cada aplicación.

The slewing bearing has to be adopted when, in a machinery or in mechanical plant, a structural part must rotate opposed to another part, along a fixed axis, ensuring the axial and radial link between the two parts. The slew bearing, with the maximum stiffness offered by its design, must bear and transmit the operative loads of the structure it is linked to, and also it must guarantee the required motion precision, the respect of operational parameters, and the required lifetime.

It is evident how the slewing bearing is a fundamental component and its choice must be done according to specific technical studies. Italcuscinetti SPA can assist your Company in the choice of the suitable bearing.

Las aplicaciones más comunes son:

- excavadoras
- hormigoneras
- vehículos elevadores
- camiones grúas
- grúas para la construcción y grúas para puertos
- compactadoras
- turbinas eólicas
- radares
- manipuladores, posicionadores
- carruseles para embotelladoras
- mesas giratorias

Common application are:

- excavators
- concrete pumps
- boomlift, manlift
- crane truck
- civil and harbour crane
- compactors
- wind turbines
- radar
- manipulators
- filling carousels
- rotary tables

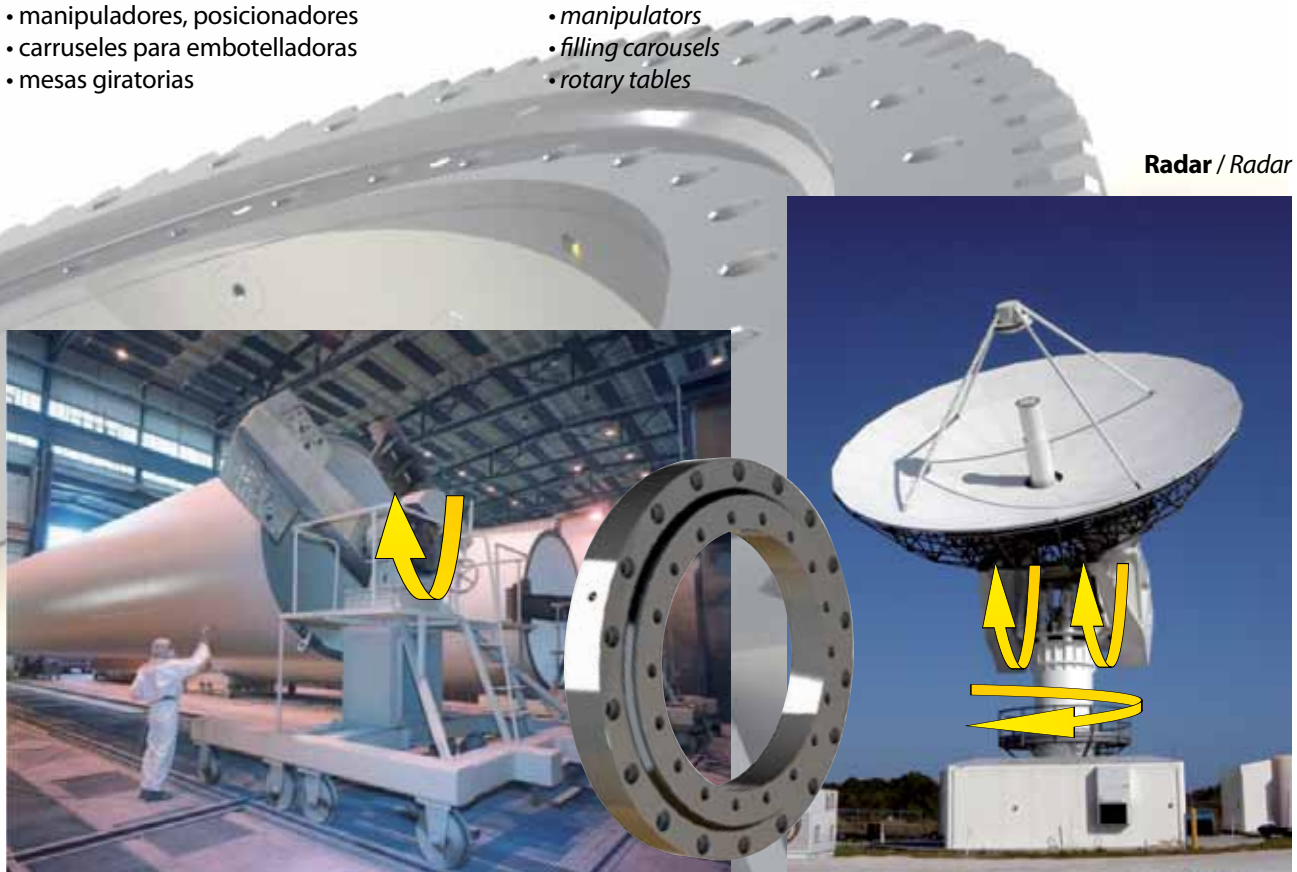

Radar / Radar

Manipulador / Manipulator

Pinzas de demolición / Demolitions calipers

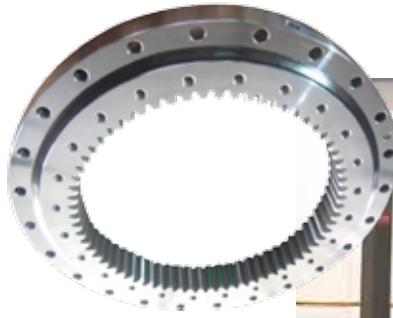

Máquinas envolvedoras
Wrapping machines

Máquinas para la madera
Forest machines

Grúas para la construcción / Civil cranes



Camión grúa / Crane truck



EXCAVADORAS / EXCAVATORS

En esta aplicación, por la tipología de las cargas transmitidas en fase operativa, la corona giratoria debe tener elevadas características de rigidez para poder contrastar las repentinas variaciones de carga, contar con buenas capacidades rotacionales - para permitir una cómoda rotación de la superestructura - y presentar además buena resistencia a eventuales golpes contra el camino de rodadura y contra el dentado. La elección de la corona giratoria ISB idónea constituye un valor añadido a la calidad general de su proyecto.

In this type of application, according to the typology of load and environmental conditions, the slew bearing must have high stiffness features, for counteracting fast load variations, good rotational features, for easy rotation of the superstructure, resistance to impact stresses in raceways and gear, in order to preserve its lifetime. The correct choice of suitable ISB slew bearings is an added value to the general quality of your project.

CONTROLAR CÓDIGOS REPUESTOS PÁG / CHECK SPARE PARTS TABLE PAG.

SERIE DE REFERENCIA REFERENCE SERIES

ER1/ZR1

Rodamiento de una hilera de rodillos cruzados
One row crossed roller bearing

EB1/ZB1

Rodamiento de una hilera de bolas con 4 puntos de contacto
One row 4 contact point ball bearing

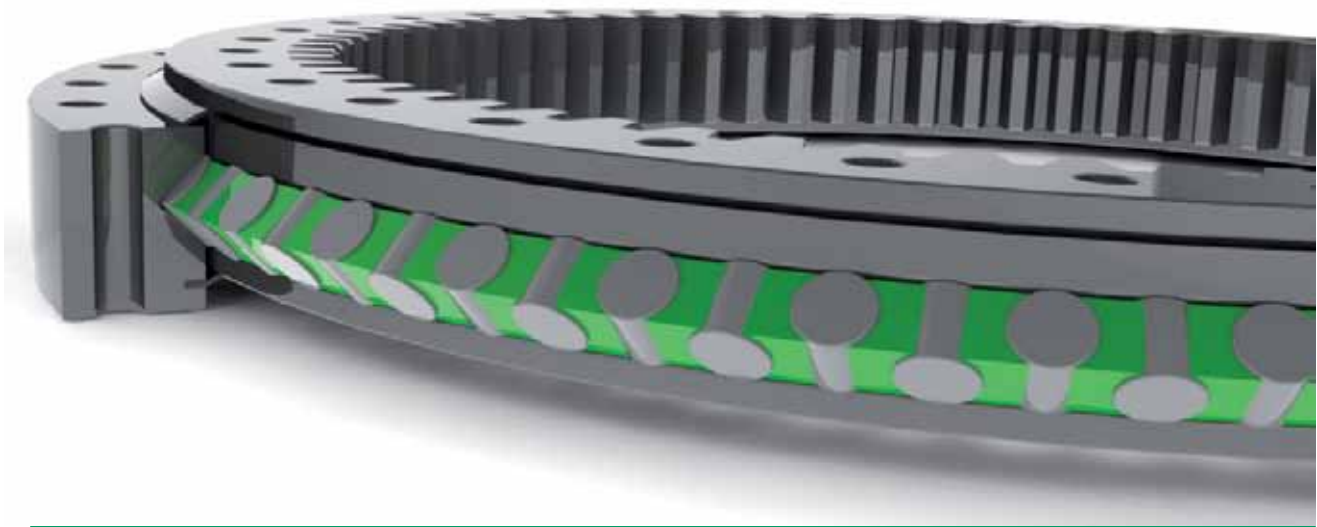

HORMIGONERAS / CONCRETE PUMPS

La corona giratoria en las hormigoneras soporta la extensión del brazo y permite a la vez su rotación. Por lo tanto está sujeta a un elevado par de vuelco. Debe también contar con una estructura compacta y permitir el montaje en vehículos. La elección en este caso recae generalmente en dos hileras de bolas con ocho puntos de contacto; también podrá elegirse una única hilera, cuando los esfuerzos lo permitan.

The slew bearing in concrete pumps supports the boom elongation also allowing its rotation, and for this reason it is subject to a huge tilting moment. It must also have a compact structure in order to be mounted on road vehicles. A common choice is a double row ball bearings, 8-contact points, otherwise if loads are much lower, it could be one-row ball bearing.



SERIE DE REFERENCIA / REFERENCE SERIES

EB1/ZB1

Rodamiento de una hilera de bolas con 4 puntos de contacto
4 contact point one row ball bearing

EB2/ZB2

Rodamiento de dos hileras de bolas con 8 puntos de contacto
8-point contact double row ball bearing



CARRUSELES PARA EMBOTELLADORAS - FILLING CAROUSELS

En los carruseles para embotelladoras la corona giratoria puede variar su diámetro, que puede ser pequeño o grande, pero las características fundamentales deben ser siempre de elevada precisión constructiva y alta velocidad de rotación; estas características deberán estar garantizadas en modo continuativo.

In filling carousels, slew bearing dimensions could vary from small to large diameter, but common characteristics are high precision construction and high continuous rotational speed.



SERIE DE REFERENCIA REFERENCE SERIES

Serie EB1 / EB1 series

Rodamiento de una hilera de bolas con 4 puntos de contacto
One row 4 contact point ball bearing

Serie EBL / EBL series

Rodamiento de una hilera de bolas con 4 puntos de contacto
- Serie con bridas
One row 4 contact point ball bearing
- Flanged series

COMPACTADORAS - COMPACTORS

Para las compactadoras, considerada la reducida velocidad de rotación del rodillo y el elevado nivel de esfuerzo por la presencia de vibraciones, la utilización de dos coronas giratorias que soporten el rodillo constituye la solución ideal.

In compactor rollers, due to low rotation speed of the roller and to the relevant stress condition in presence of vibrations, the use of a pair of slew bearings supporting the roller is an ideal solution.



SERIE DE REFERENCIA / REFERENCE SERIES

Serie NB1 / NB1 series

Rodamiento de una hilera de bolas con 4 puntos de contacto, sin dentado
One row 4 contact point ball bearing, untoothed

VEHÍCULOS ELEVADORES - *BOOMLIFT, MANLIFT*

Aplicación típica de la corona giratoria. El rodamiento giratorio soporta toda la carga saliente de la plataforma aérea.

This is a typical application of the slewing bearing. The whole overhang load of the aerial platform is entirely supported by the bearing.



SERIE DE REFERENCIA REFERENCE SERIES

Serie EB1/ZB1 EB1/ZB1 series

Rodamiento de una hilera de bolas con 4 puntos de contacto
One row 4 contact point ball bearing

Serie EB2/ZB2 EB2/ZB2 series

Rodamiento de dos hileras de bolas con 8 puntos de contacto
Double row 8 contact point ball bearing

PINZAS DE ELEVACIÓN GIRATORIAS - *ROTATING CLAMP*

En las carretillas elevadoras muchas veces es necesario contar con pinzas de elevación capaces de girar el objeto levantado, por razones tales como el vertido del contenido de la carga o para permitir su manipulación dentro de los ciclos de producción y de almacenaje.

On the forklifts it is often necessary to have a lifting clamp able to rotate the lifted object, with the possibility to pour its content or else to allow its handling in the production and storage cycles.



SERIE DE REFERENCIA / REFERENCE SERIES

Serie EB1 / EB1 series

Rodamiento de una hilera de bolas con 4 puntos de contacto, dentado exterior
One row 4 contact point ball bearing, external toothed

POSICIONADORES PARA SOLDADURA - WELDING POSITIONERS

Se monta un rodamiento en la base del brazo de los robots de soldadura para soportar la estructura saliente y permitir la acción rotativa; en esta aplicación se requiere además una elevada rigidez, para garantizar la necesaria precisión en el posicionamiento.

A slew bearing is applied to the base of the arm of welding robots, in order to support the overhang structure and allow its rotational motion; moreover, high stiffness is required in order to ensure precision in positioning.



SERIE DE REFERENCIA
REFERENCE SERIES

MESAS GIRATORIAS - ROTARY TABLES

ZR1/ZB1

En las máquinas herramientas, donde resulta necesario un control micrométrico de la posición de la pieza, en la base de las mesas giratorias se monta un rodamiento YRT. Este rodamiento responde a los máximos requisitos de precisión, no presenta juegos y está completamente rectificadas, interna y externamente. El suministro estándar incluye certificados de control dimensional.

In machining centers, where a micrometric control of piece positioning is required, a YRT type bearing is installed on the turntable base. YRT is produced according to the highest precision requirements, completely grinded internally and externally, and assembled without any radial and axial clearance. The standard supply of this product also provides dimensional check certificates.



SERIE DE REFERENCIA / REFERENCE SERIES

Serie YRT / YRT series

Rodamientos estándares para mesas giratorias
Standard rotary table bearings.

Serie YRTS / YRTS series

Agrega alta velocidad, bajo par de fricción
Adding high speed, low frictional torque



GRÚAS PARA PUERTOS Y NAVALES - *HARBOUR & DECK CRANES*

Las grúas para puertos y las grúas navales representan uno de los campos de aplicación fundamentales de las coronas giratorias: su utilización resulta imprescindible para soportar la estructura, sujeta a exigentes condiciones de carga, características de la manipulación de los materiales de los containers. Italcuscinetti SpA ofrece a sus clientes un estudio técnico de diseño o de verificación del rodamiento en todas sus partes y además suministra todos los certificados de conformidad/materiales que deben acompañar este tipo de suministros.

Harbour and deck cranes represent one of the most important application field for slew bearings: their use is fundamental to support the structure subject to extreme load conditions, such as the handling of containers. Italcuscinetti SPA is able to design or to verify the suitable slew bearing in each part it is composed, and also to provide the compliance/material certificate usually required in this type of supply.



SERIE DE REFERENCIA REFERENCE SERIES

Serie ER3 y ZR3

ER3 & ZR3 series

Rodamiento de tres hileras de rodillos cruzados

Triple-row crossed roller bearing

Serie ER1 y ZR1

ER1 & ZR1 series

Rodamiento de una hilera de rodillos cruzados

One-row crossed roller bearing

TURBINAS EÓLICAS - *WIND TURBINES*

En este tipo de aplicación las coronas giratorias constituyen componentes funcionales fundamentales y su diseño varía en base a la función que cumple la torre eólica. El primer tipo de rodamiento se llama Blade Bearing "B" y está fijado en la base de cada pala y permite su orientación. El segundo tipo se llama Yaw Bearing "Y" y está fijado en la base de la unidad, permitiendo la orientación de toda la turbina. El tercer tipo se llama Main Bearing "M" y permite la transferencia del movimiento giratorio de la turbina al alternador.

For this type of application the slew bearings are extremely important functional component and their design changes according to their position in the wind turbine. The first type is called Blade Bearing "B", it is fixed in the base of each blade allowing its orientation. The second type is the Yaw Bearing "Y", it is fixed on the base of the nacelle and it allows the orientation of the whole turbine. The third type is called Main Bearing "M" and it allows the motion transfer from the turbine to the generator.

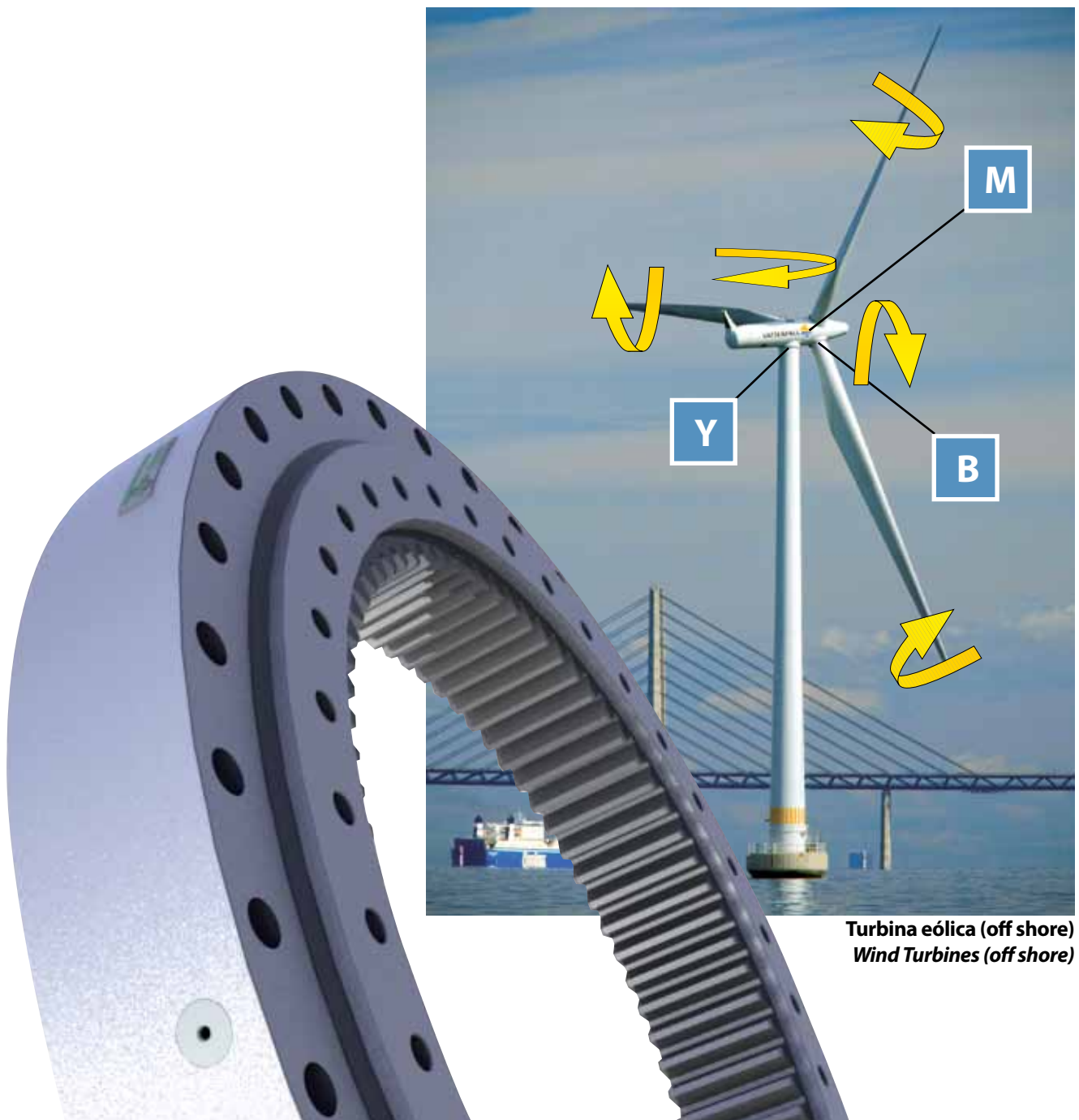

**Turbina eólica (off shore)
Wind Turbines (off shore)**

COMPONENTES DE LA CORONA GIRATORIA - *SLEW BEARINGS COMPONENTS*

Normalmente las coronas están formadas por dos anillos de acero de alta resistencia cuyo movimiento rotativo viene facilitado a través de la creación de pistas de rodadura que contienen las bolas o los rodillos cilíndricos. Las pistas de rodadura son el corazón de la estructura del rodamiento y los elementos a los cuales hay que prestar la mayor atención durante el ciclo de producción. Deberán ser tratadas térmicamente, no sólo en superficie sino también en profundidad, para permitirle soportar las pesadas cargas que les suelen ser conferidas dotándolas de integridad en el tiempo.

The slew bearing is normally composed of two rings made of high resistance steel, and their relative rotating motion is allowed by the creation of raceways hosting the rolling elements, which can be balls or cylindrical rollers. The roller raceways are the structural heart of the bearing and require the major attention during the production cycle. An induction hardening treatment must be applied on raceways in order to increase their hardness both on the surface and in depth. This allows the bearing to endure the huge loads it is usually subject to, ensuring structural integrity over time.



Serie EBL / EBL series

Rodamiento de una hilera de
bolas con 4 puntos de contacto
One row 4 contact point ball

Rodamiento con bridas
Flanged bearing

Componentes estándares de una corona giratoria Standard components of a slewing bearing

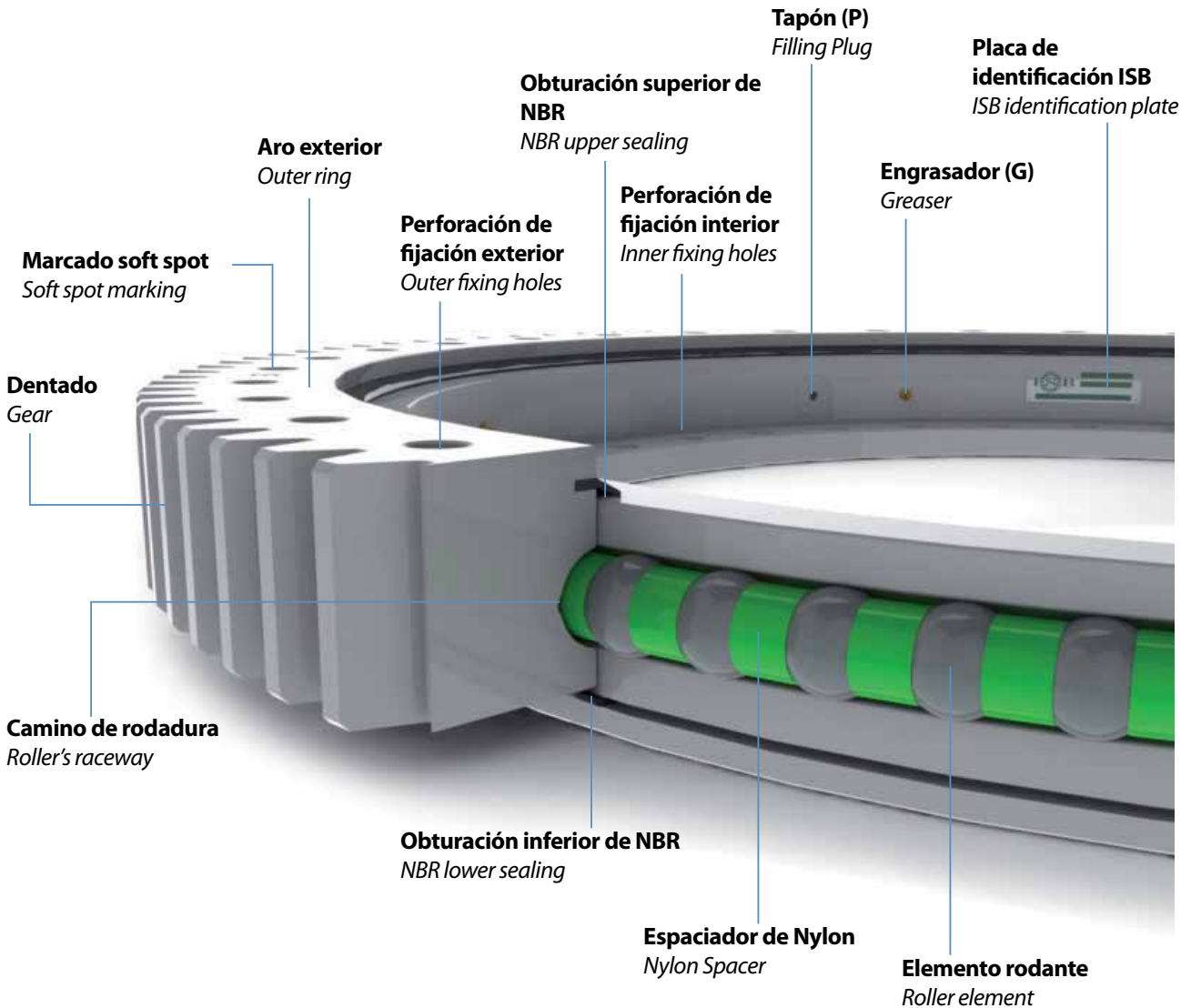

Elementos rodantes Rolling elements

Bolas DIN 5401 se utilizan para rodamientos de cuatro puntos de contacto mientras rodillos cilíndricos DIN 5402 para rodamientos de rodillos: ambos componentes están realizados con material 100 Cr6. La dimensión de las bolas o de los rodillos se puede identificar fácilmente gracias a la sigla misma presente en el rodamiento (véase pag. 56).

DIN5401 balls are used for four point contact bearings while DIN5402 cylindrical rollers are used for crossed roller bearings: both types of rolling elements are made of 100 Cr6 material. Rolling element diameter can be taken from the code of the slew bearing as per the designation (see pag. 56).

Espaciadores

Spacers

Se emplean espaciadores de nylon para mantener los componentes para la rotación (bolas, rodillos) separados entre sí, evitando cualquier contacto entre los mismos.

Nylon spacers are used to guide the rolling elements, to hold them at an equal distance from each other and to prevent them from coming into contact with each other.

Obturaciones

Sealing

El material utilizado para la obturación es la goma NBR. La obturación cierra el vacío que se crea entre un aro y otro, evitando la entrada de suciedad, polvo y humedad. Una correcta lubricación incrementa la eficacia de la obturación (véase Lubricación de los caminos de rodadura pág. 145)

Seals made from NBR rubber protect the gap in the bearing on both sides from the ingress of dirt, dust and moisture. Please note that a correct lubrication increases the effectiveness of the seals (see Raceway Lubrication page 145)

Grasa

Grease

Nuestros rodamientos se suministran con una lubricación inicial de los caminos de rodadura y del dentado con grasas específicas enumeradas en la sección Lubricación, parte 4 Instalación y Mantenimiento. Seguir atentamente las instrucciones suministradas para preservar la vida del rodamiento.

Our bearings are delivered with an initial lubrication of raceways and gear, using grease listed in the lubrication section , part 4 Installation and Maintenance. Strictly follow the instructions supplied in order to preserve the lifecycle of the bearing.

Engrasadores

Greasers

Están emplazados en el diámetro del aro sin dentado (para los rodamientos sin dentado están ubicados en el aro exterior) y sirven para engrasar el alojamiento de rodadura de los elementos rodantes.

They are located on the diameter of the ungeared ring (for the bearings without gear teeth they are located on the outer ring) and they are used to grease the raceway.

MATERIALES PARA LOS AROS - RINGS MATERIAL

Los materiales con los cuales se realizan las coronas giratorias pueden ser aceros al carbono, como el C45, o bien aceros aleados como el 42CrMo4. La elección entre los dos materiales está esencialmente relacionada con las características mecánicas requeridas, como por ejemplo la tenacidad y la dureza, como así también con factores tecnológicos. El 42CrMo4 ofrece la posibilidad de obtener una mayor profundidad de la capa de temple de los caminos de rodadura y por lo tanto mayores capacidades de carga. El C45 (o equivalente) es el material con el que se construyen la mayor parte de los rodamientos estándares de diámetro medio-reducido, el 42CrMo4 se emplea para diámetros medio-elevados y para múltiples construcciones especiales.

The materials used to produce slew bearings can be carbon steel, as C45, or alloy steel, as 42CrMo4. The choice between these two types of steel is related to the required mechanical performances, like core-tenacity and hardness, but also to other technological factors, as hardenability. The 42CrMo4 allows a deeper thickness of the hardened layer than C45, ensuring higher load capacity. The C45 (or equivalent) is the material used for the production of the major part of standard medium- low diameter bearing, the 42CrMo4 is used for medium-high diameters, and for many different special applications.



	UNI Italia Italy	DIN Alemania Germany	EURO NORM Europa Europe	AISI -SAE USA	GB China China	BS 970 Inglaterra England	JIS Japón Japan
Aceros al carbono Carbon steel	C45	C45, CK45	C45	1045	C45, 50Mn	EN8D	S45C S48C
Acero aleado Alloyed steel	42CrMo4	42CrMo4	42CrMo4	4140	42CrMo	En19A	SCM440

Tabla 1 - correspondencia en las diferentes unificaciones de las denominaciones de los aceros para coronas giratorias
Form 1 - correspondance of steel used for slewing bearing production, in various normative

Después del forjado y la laminación, el material es sometido a un tratamiento térmico, que puede ser de bonificación o de normalización, para incrementar todas sus características mecánicas, como por ejemplo la resistencia a la tracción, la tenacidad, la dureza y la templabilidad. El ciclo de bonificación, que prevé un tratamiento de temple y uno de revenido, confiere al material una dureza y una resistencia mayor de la normalización, características necesarias para dentados sujetos a máximos esfuerzos mecánicos y ambientales.

After forging and ring mill, a heat treatment, either core-hardening or normalization, must be applied in order to increase all mechanical proprieties of the material, such as tensile strength, tenacity, hardness. The core-hardening process, composed by a succession of quenching and tempering heat treatments, confers to the material higher hardness and higher core-resistance values than normalization, proprieties required in case of heavy stress conditions on the gear.



TEMPLE POR INDUCCIÓN DE LAS LOS CAMINOS DE RODADURA - INDUCTION HARDENING OF RACEWAYS

El tratamiento de temple de los caminos de rodadura, elevando el respectivo valor de dureza superficial y profunda entre 55 y 62 HRC, sirve para aumentar la capacidad de carga del rodamiento y para preservar los caminos de rodadura de fenómenos de plastificación debidos a las presiones de contacto con los elementos rodantes. Este tratamiento consiste en el acercamiento del camino de rodadura a un inductor de cobre atravesado por corriente alterna de gran amperaje. El acercamiento del campo magnético variable al camino de rodadura metálico induce corrientes parásitas locales, las cuales, por efecto joule, recalientan inmediatamente la zona interesada más allá de la temperatura de austenización, la cual luego es enfriada en salida para permitir la formación de martensitas y carburos. La elección de un acero al carbono como el C45 o aleado como el 42CrMo4 está precisamente supeditada a la obtención de los mejores resultados metalúrgicos durante este procedimiento.

The heat treatment of rollerways, increasing the hardness value on surface and in depth up to a value range of 55 ÷ 62 HRC, involves a higher load capacity of the bearing and avoid plastic deformation along rollers contact points. This heat treatment consists in bringing a copper made inductor crossed by high amperage alternate current nearer to the rollerways. The proximity of magnetic field to the metallic rollerway induces parasite currents and Joule effect that produces an instantaneous heating of interested regions leading to the austenite temperature field. The following quick cooling produces the formation of martensite and carbides.

The choice of a carbon steel, as C45, as well as an alloy steel, as 42CrMo4, allows to obtaining best metallurgical results during this process.



Soft spot "S"

El soft spot (punto blando) es un punto de los caminos de rodadura de ambos aros que no ha sido templado por inducción, ya que al finalizar el proceso de temple no resulta posible superponer las separaciones del temple mismo porque se corre el riesgo de agrietamientos o incluso rotura de la pieza. Para el aro no dentado es conveniente hacer coincidir el soft spot con el punto de inserción de las bolas, es decir con el tapón, que se mecaniza conjuntamente con los caminos de rodadura.

Para el aro dentado se hace en cambio necesaria la indicación con una letra "S" impresa en la cara superior del aro, en la zona del soft spot.

The soft spot is a raceway point that has not been induction hardened, due the fact at the end of hardening process it isn't possible to overlay the hardening ends, the risk is to generate cracks or directly to produce the breaking of the piece. For the untoothed ring is a common rule to make the soft spot coincident with the filling plug, the inserting point of roller elements, machined together to the raceways. In order to identify the soft spot on the geared ring it is necessary to stamp a "S" letter on the upper surface of the bearing, in corresponding position.

TEMPLE POR INDUCCIÓN DE LOS DIENTES - *INDUCTION HARDENING OF THE GEAR*

La dureza superficial estándar del material bonificado utilizado llega a un máximo de 30 HRC (42CrMo4). Este valor de dureza no siempre resulta aceptable para preservar la vida útil del dentado en algunas aplicaciones. Un par de rotación elevado que produce un elevado esfuerzo (de fricción) sobre el diente, altas velocidades de rotación, condiciones ambientales desfavorables con presencia de polvo o elementos abrasivos, como así también la necesidad de llevar el ciclo de vida útil de la corona giratoria a su máximo nivel, exigen que el temple por inducción se efectúe también en el dentado. El tratamiento puede efectuarse sólo en el costado del diente o bien en el costado y en el fondo del diente, según las cargas y el tipo de aplicación, llevando el valor de dureza superficial hasta un máximo de aproximadamente 60 HRC.

The standard surface hardness of core-hardened steel used for bearing could be 30 HRC at maximum (42CrMo4). This value of hardness could not be enough to preserve the lifetime of the gear in some applications. A high rotational torque producing a high load (and friction) on the tooth, high rotational speed, heavy duty environmental condition including dust and abrasive elements, or the necessity to extend the lifecycle of the bearing to the maximum, any of those aspects may require a gear induction hardening. The heat treatment could be only flank or flank & root of the teeth, according to loads and application type, and it leads the surface hardness value to a maximum value of about 60 HRC.



Temple del diente en el costado y en el fondo

Gear hardening flank and root of the teeth

TIPOLOGÍAS DE JUEGOS - CLEARANCE TYPE

El juego de una corona giratoria es la medida del movimiento libre del aro exterior respecto al interior (y viceversa), evaluado en dos direcciones: en sentido axial, es decir en la dirección definida por el eje de rotación, y radial, es decir en cualquier dirección perpendicular al eje mismo. El juego de la corona giratoria está determinado por el acoplamiento de los elementos rodantes con los caminos de rodadura de los aros componentes, cada uno de ellos con su respectiva tolerancia. La corona giratoria se puede presentar con cuatro tipologías de juegos diferentes, ya sea que presente bolas o rodillos. La determinación de los juegos se define con la elección del tipo de corona giratoria y depende del campo de aplicación de la corona giratoria misma.

Clearance of a slew bearing is the measure of the motion freedom of the outer ring compared to the inner ring (and vice versa), evaluated in two directions: along the axial direction, defined by the revolution axis of the bearing, and along radial direction, any direction perpendicular to the first one. When assembling, the plays of the bearing is determined by matching rings raceways with rollers, each component having its tolerance. The slew bearing can show four different types of clearances, both ball and crossed roller bearing. The type choice is done simultaneously to bearing type selection, and mainly depends on the application field.

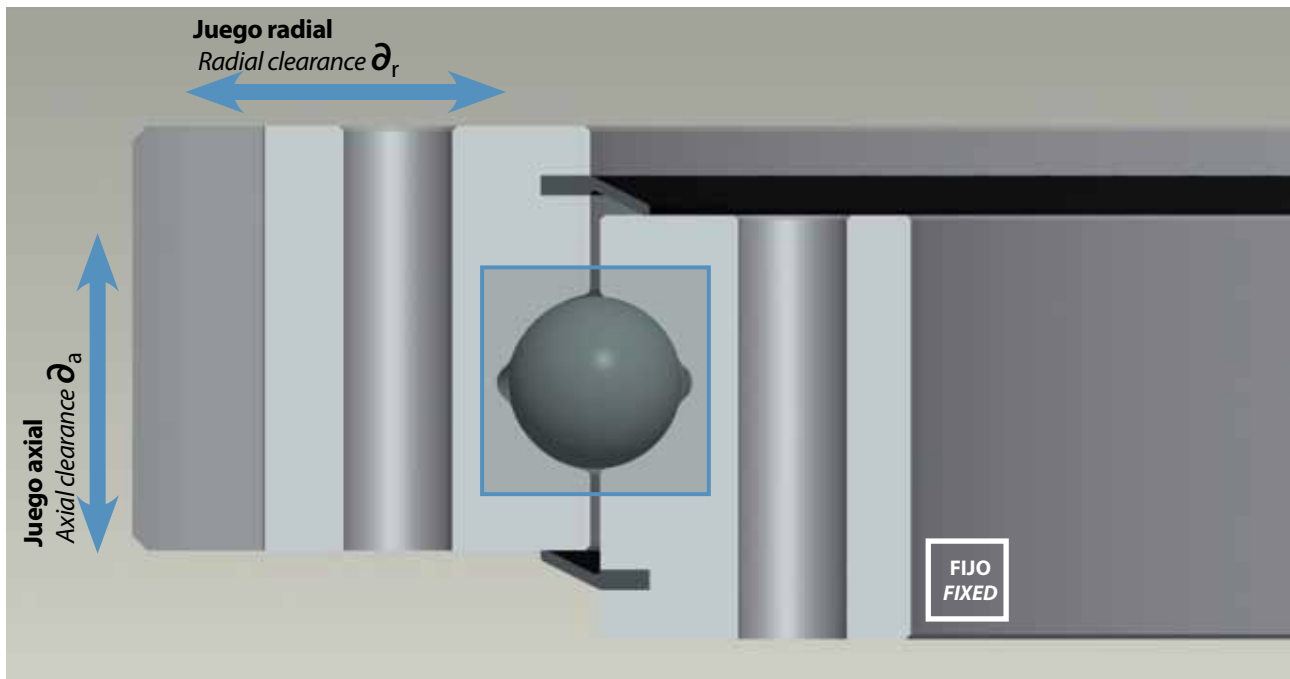

Representación del juego axial y radial de la corona giratoria
Slew bearing axial and radial clearance representation

A continuación se describen los diversos casos para que Usted pueda efectuar la elección ideal para su aplicación. Está de todos modos siempre a su disposición para cualquier consulta la oficina Técnica ISB.

On the following page you can find the description of the different cases so that you can make the best choice for your application. ISB technical center is always available to support you.

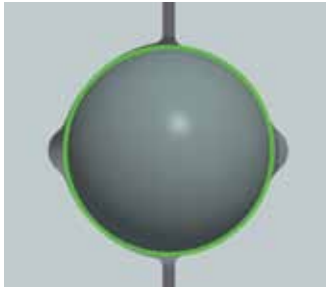

→ Catálogo Estándar
Catalogue Standard
Serie / Series

Juegos estándares / Standard Clearance $\partial_a, \partial_r \rightarrow 0,10 \div 0,35 \text{ mm}$

Normalmente en una corona giratoria se prevén juegos estándares axiales y radiales que pueden variar, según el tipo de rodamiento, de 1 a 4 décimas de milímetro. La presencia de los centrados en los aros está en función de la aplicación y/o del tipo de corona giratoria: en la serie estándar de bolas, por ejemplo, los centrados son opcionales, en los rodillos en cambio son de serie.

Usually in a slew bearings axial and radial clearance can vary from 0,1 to 0,4 mm. Pilots are function of application and/or type of bearings: on standard balls series, for example, pilots are optional, in standard roller series pilots are for standard construction.

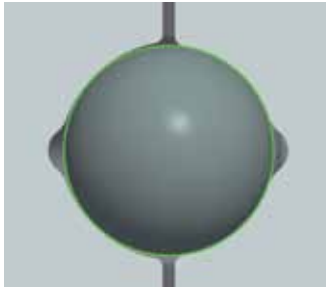

→ Catálogo de precisión
Catalogue Precision
Serie / Series

Juegos reducidos / Reduced Clearance $\partial_a, \partial_r \rightarrow 0 \div 0,10 \text{ mm}$

Cuando la aplicación requiere la máxima precisión durante la fase operativa, conservando siempre una elevada velocidad de rotación, el diseño de la corona giratoria cambia en favor de una reducción del juego axial y radial. Los juegos pueden variar desde un valor nulo a pocas centésimas con signo positivo. Las series de precisión adoptan las dimensiones generales de las series estándares y presentan centrados centesimales en ambos aros.

When the application requires the maximum precision during operation, with high values of rotational speed, the slew bearing design changes in favor of a reduction of axial and radial plays. Clearance can vary from null value to few hundreds of millimeter, in positive value. Precision series adopt general dimensions of standard series and show pilots on both rings.

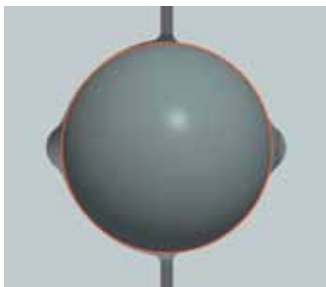

Diseño especial
Special design

Ligera pre-carga / Slight preload $\partial_a, \partial_r \rightarrow 0 \div - 0,03 \text{ mm}$

Cuando la aplicación requiere la ausencia de holguras, tanto radiales como también axiales, por ejemplo para eliminar toda imprecisión en el posicionamiento o porque la corona giratoria trabaja en posición vertical, se anula el juego y la construcción se denomina "con precarga". Cuando la precarga es ligera, es decir con interferencias que varían de un valor nulo a un valor negativo a pocas centésimas, la corona giratoria logra conservar una adecuada capacidad de rotación, incluso con intensos ciclos de funcionamiento y con limitados pares de fricción. Este tipo de construcción no es estándar y se deberá requerir específicamente.

When the application requires the absence of any plays, radial and axial, in order for example to avoid any positional error or because the bearing works in vertical position, the clearance is eliminated and the construction is called "with preload". When the condition is slight preload the design interference between rollers and raceways can vary from zero to few hundreds of millimeter: the slew bearing shows anyway an adequate rotational speed, even on intense operational cycles, with a limited friction torque. This type of construction is not standard and must be specifically requested.

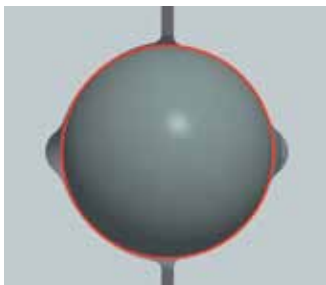

Diseño especial
Special design

Pre-carga / Preload $\partial_a, \partial_r \rightarrow \leq - 0,03 \text{ mm}$

Cuando el tipo de esfuerzos prevé fuertes pares de vuelco que pueden invertir en modo imprevisto la dirección y existe también la posibilidad de esfuerzos por vibraciones en los caminos de rodadura, la construcción de la corona giratoria presentará una elevada pre-carga. Los valores de interferencia, siempre negativos, se calcularán en modo tal de garantizar la funcionalidad del rodamiento y al mismo tiempo respetando valores límites de diseño en lo que respecta al par de fricción, estático y dinámico. Este tipo de construcción no es estándar y se deberá requerir específicamente.

When load conditions includes relevant tilting moments that may quickly invert their direction and the eventual presence of vibration which involves rollerways, the slew bearing construction must be strongly preloaded. Interference range shows only negative values and its calculation is performed to guarantee the functionality of the bearing and, at the same time, to observe design limit values of static and dynamic friction torque. This type of construction is not standard and must be specifically requested.

SISTEMAS DE PROTECCIÓN SUPERFICIAL - SURFACE PROTECTION SYSTEM

El tratamiento de protección superficial preserva las superficies metálicas exteriores de la oxidación por efecto de agentes atmosféricos o químicos, durante la vida de funcionamiento del rodamiento o simplemente durante su período de almacenaje. Podemos efectuar los siguientes tratamientos de protección superficial, según sus exigencias.

The external surface protection treatment protects metallic surfaces from their oxidation caused by atmospheric or chemical agents, during operational lifetime or simply during the storage period.

We can apply the following different surface protection treatments, according to your needs.

Aceite protectorio - Protective Oil Estándar - Standard

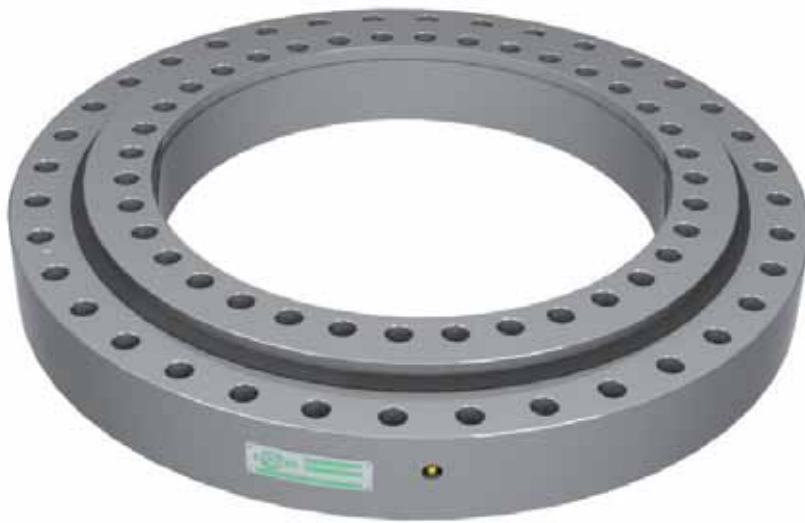

Todas las coronas giratorias ISB están protegidas con aceite protectorio aplicado sobre las superficies, las obturaciones y los dentados. Esto garantiza una protección constante durante el transporte y el almacenaje por aproximadamente 1 año.

All ISB slew bearings are protected with applying oil to surfaces, seals and gear. It allows a constant protection for about 1 year.

Pintado - Painting

Bajo demanda / On request

Bajo demanda del cliente se podrá efectuar un tratamiento de pintado protectorio de las superficies expuestas.

Exposed surfaces can be protected by painting, on customer request.



SISTEMAS DE PROTECCIÓN SUPERFICIAL - SURFACE PROTECTION SYSTEM

Cincado galvánico - Zinc based galvanized coating

Bajo demanda / On request

En caso de agentes atmosféricos y químicos agresivos se podrá aplicar un recubrimiento químico a base de Hierro-Cinc. La capa será de pocos centésimos pero permitirá una protección resistente con su típico color amarillo iridiscente.

In case of atmospheric or chemical agents a Fe-Zn galvanized layer can be applied. The thickness is just few hundreds of mm but it allows a durable protection with its typical iridescent yellow color.

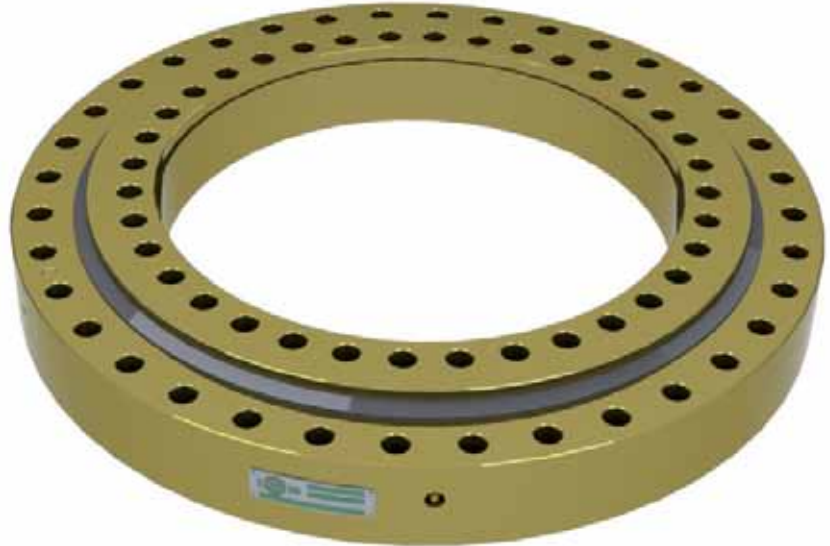

Galvanizado spray en caliente - Hot flame spray zinc coating

Bajo demanda / On request

Galvanizado spray en caliente: la capa de protección puede alcanzar algunas décimas de espesor y resulta ideal para contrastar cualquier tipo de agente atmosférico, ya que es resistente también a acciones de abrasión y golpes sobre las superficies.

This treatment can apply a protective layer up to 3 ten of millimeter thickness. It resists to any type of atmospheric agent and also to abrasive action on surface.

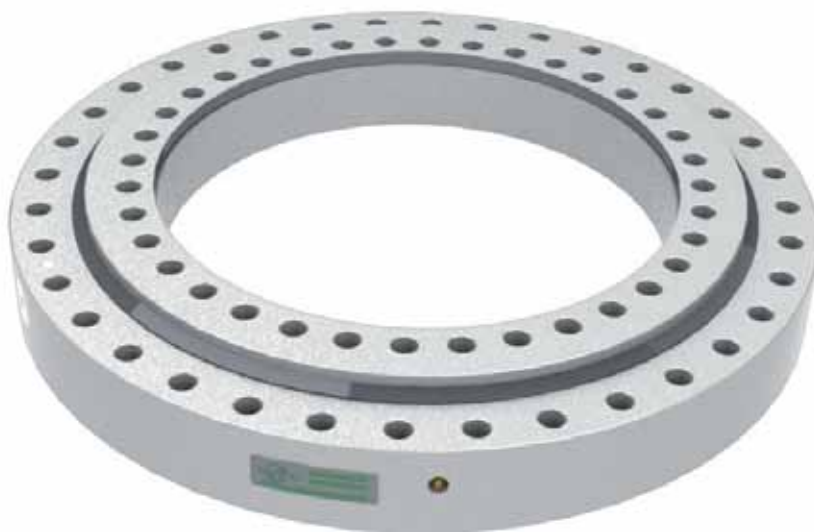





PARTE 2 - ELECCIÓN DE LA CORONA GIRATORIA

PART 2 - SLEW BEARING SELECTION

INTRODUCCIÓN - INTRODUCTION

La elección del rodamiento para una determinada aplicación no puede prescindir, además de consideraciones de tipo general sobre la tipología y las características macro-geométricas, de las siguientes verificaciones:

- capacidad estática y dinámica del sistema de rodadura **(A)**
- resistencia del sistema de fijación en la estructura **(B)**
- resistencia del acoplamiento con un eventual piñón **(C)**

El análisis de estas temáticas puede ser afrontado desde un punto de vista teórico sobre la base de las propiedades mecánicas del rodamiento y de los esfuerzos y deformaciones que se crean luego de la aplicación de las cargas.

The choice of the bearing for each application depends not only on its macro-geometric specifications but also on the evaluation of the following elements:

- *the static and dynamic capacity of the rolling system **(A)***
- *the resistance of the fixing system to the structure **(B)***
- *the resistance of the gear coupling with a pinion **(C)***

From a theoretical point of view these topics could be analyzed considering the mechanical features of the bearing and the stress and strain due to the application of loads.

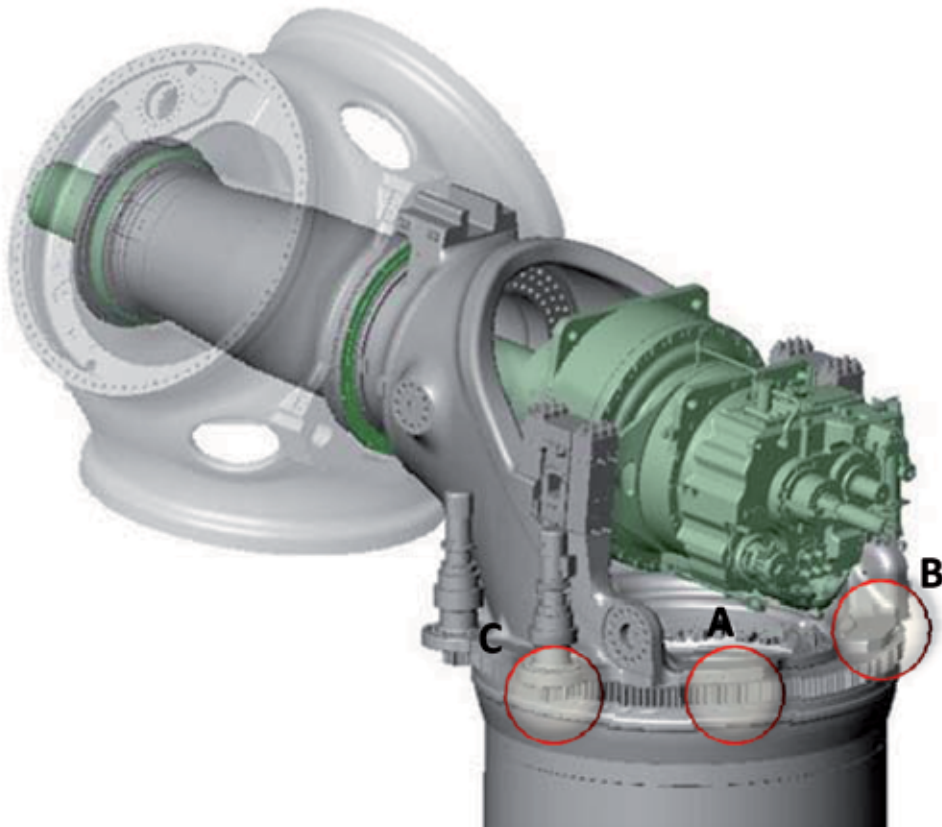

CAPACIDAD ESTÁTICA - STATIC CAPACITY

Un rodamiento está normalmente sujeto a una condición de carga compuesta por una carga axial uniformemente distribuida (F_a), un momento de flexión de vuelco (M_f) y una carga radial (F_r).

Usually, a bearing is subject to a load case which includes an axial load uniformly distributed (F_a), a tilting moment (M_f) and a radial load (F_r).

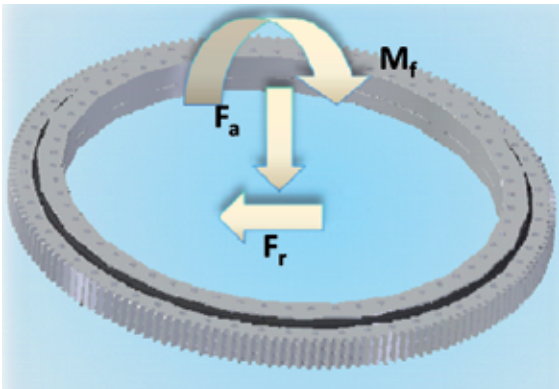

La verificación estática se efectúa a través del cotejo de la máxima carga equivalente que incide sobre cada cuerpo rodante respecto a la carga máxima admisible; el cálculo se efectúa sobre la base de las especificaciones contenidas en el estándar internacional ISO 76.

The static capacity is based on the comparison between the maximum equivalent load on the single rolling element and the maximum allowable load. The calculation is done according to the specifications listed in the international standard ISO 76.

La carga equivalente (Q_{eq}), es decir la máxima carga incidente sobre el cuerpo rodante en dirección normal en la superficie de contacto, está supeditada a las cargas incidentes sobre el rodamiento a través de los coeficientes C_1 , C_2 y C_3 que dependen de la tipología (bolas o rodillos), de la dimensión y la geometría del rodamiento mismo y de las características mecánicas:

The equivalent load (Q_{eq}), the maximum load applied to the single rolling element along the perpendicular direction to the contact surface, is a function of the loads applied to the bearing through some coefficients C_1 , C_2 and C_3 which depend on the type and dimension of the bearing itself:

$$Q_{eq} = C_1 \frac{F_a}{z} + C_2 \frac{M_f}{D_L z} + C_3 \frac{F_r}{z}$$

z = número de bolas-rodillos
number of balls-rollers

D_L = Diametro de rodadura
rolling diameter

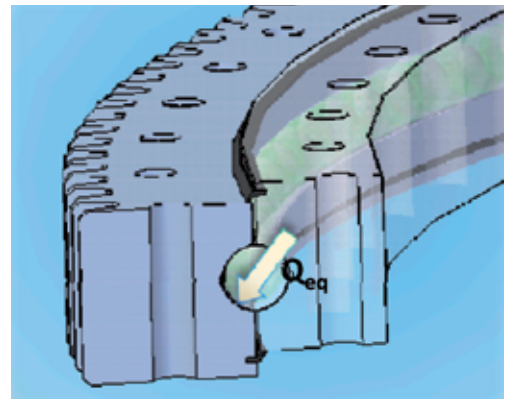

El cálculo de la carga admisible presupone en cambio un preciso estudio de esfuerzos de las solicitaciones de la zona de contacto entre el cuerpo rodante y el camino de rodadura.

El análisis de los esfuerzos y de las deformaciones se efectúa sobre la base de la teoría elástica del contacto de Hertz.

En la zona de contacto, en el centro del área interesada por el estado de deformación, se crea un estado de esfuerzo que tiene la siguiente evolución :

For the estimation of the allowable load, it's necessary a deep study of the state of stress in the contact area between the rolling element and the raceway.

The analysis of stresses and strain is based on the elastic theory of the Hertzian contact.

In the contact area, in the middle of the area subject to the state of deformation, a stress distribution is produced, which has a trend similar to the one reported in the following:

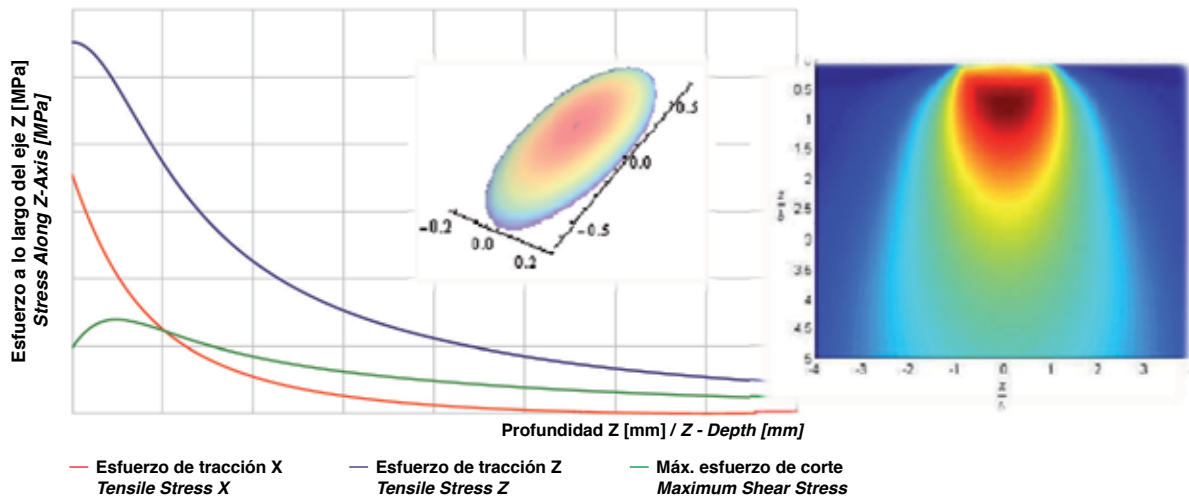

La carga admisible se evalúa por lo tanto suponiendo que la deformación plástica de la zona de contacto entre cuerpo rodante y camino de rodadura no supere el 0,01% del diámetro de la bola o del rodillo⁽¹⁾. Dicha situación límite garantiza en efecto la funcionalidad del rodamiento en términos de nivel de ruido y durabilidad a la fatiga teórica:

The allowable load is calculated considering that the plastic deformation of the contact area between the rolling element and the raceway is less than 0,01% of the ball/roller diameter⁽¹⁾. It guarantees the functionality of the bearing both in terms of noise and life rating:

$$Q_0 = kD_w^2$$

El factor k depende del curvado de cuerpo rodante y camino de rodadura y de las características mecánicas de los materiales en juego.

Factor k depends on the radius of curvature of both the rolling element and the raceway and on the mechanical characteristics of the materials.

⁽¹⁾ Condición válida para aros templados en profundidad. / Condition valid for through hardened bearings.

Ya que los materiales utilizados para la mayor parte de las aplicaciones mecánicas no cuentan con temple profundo, para mejorar las características mecánicas del camino de rodadura y aumentar así la capacidad estática y dinámica del rodamiento se realiza un tratamiento térmico de temple por inducción, capaz de garantizar una dureza del material equivalente al de los cuerpos rodantes (aprox. 60 HRC) hasta una cierta distancia de la superficie de contacto:

Since the materials used for most of the mechanical applications aren't usually core-hardened, an induction hardening heat treatment is applied in order to improve the mechanical proprieties of the raceways and, in that way, to increase the static and dynamic capacity of the bearing. This treatment guarantees a material hardness equivalent to the value of the rolling elements (about 60 HRC), up to a certain depth of the contact surface.



La profundidad de temple se define de vez en vez en base a la verificación "core-crashing" del rodamiento. La norma de referencia es la ASME 77-DE-39.

Bajo la superficie de contacto del camino de rodadura se crea un estado de esfuerzo compuesto, cuya evolución se deduce en base a la teoría elástica de Hertz o en base a los más modernos métodos de cálculo de elementos acabados.

En coincidencia con la transición entre la zona templada y el "corazón" del aro se presenta una repentina disminución de las propiedades mecánicas del material. Es precisamente en esta zona que se pueden producir micro-fracturas debidas a la deformación plástica del material, las cuales aflorando determinan visibles facturas perpendiculares a la superficie de contacto.

The hardening depth is defined in each bearing according to the "core-crashing" verification of the bearing. The reference normative is ASME 77-DE-39.

Under the contact surface of the raceway it appears a composite stress condition, and its distribution can be calculated by using the Elastic Theory of Hertz or the modern finite element simulation. In correspondence of the transition of the hardened zone and the "heart" of the bearing there is a quick decrease of mechanical proprieties of the material. In that zone, due to the plastic deformation of the material, micro fractures can appear rising up to the surface showing perpendicular fracture lines on contact surface.

Para evitar este fenómeno es por lo tanto necesario extender la zona templada alcanzando una profundidad tal que evite la deformación plástica del material de base que comprometería la resistencia misma del rodamiento:

To avoid this phenomenon it is necessary to extend the hardened layer of the material up to a depth which is enough to prevent plastic deformation which would compromise the resistance of the bearing itself.

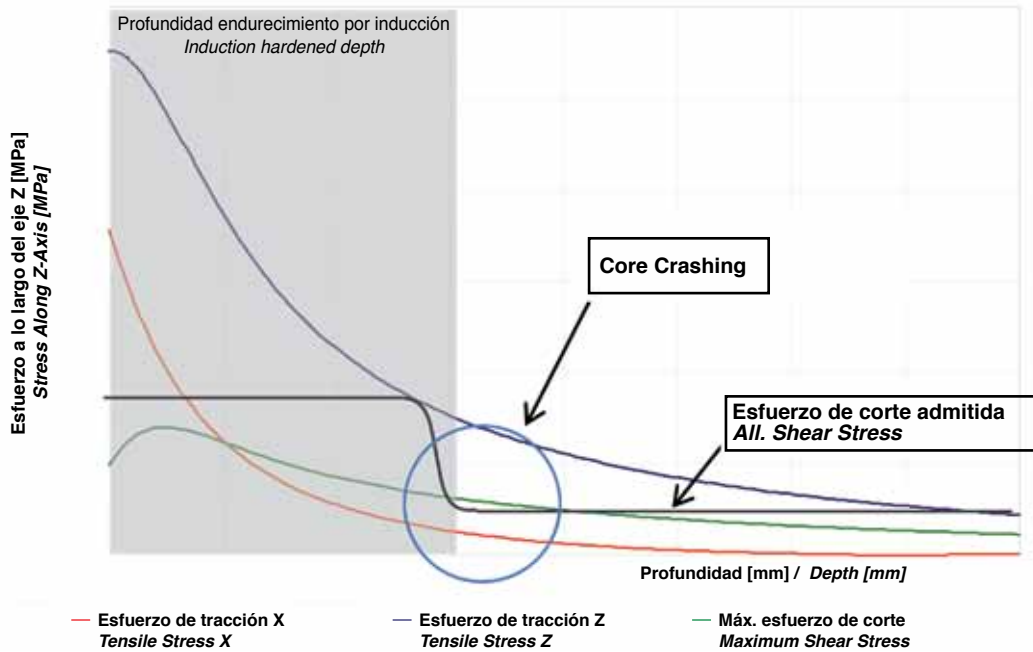

La elección del material resulta por lo tanto importante tanto para garantizar la templabilidad del camino de rodadura hasta profundidades incluso elevadas, como también para garantizar las características de resistencia requeridas en el corazón del aro.

The choice of the material is therefore important both to ensure the hardenability of the raceways to the desired depth and to ensure the strength characteristics required in the core of the ring.:

$$\tau_{hertz}(z = RHT) < \tau_{core all.}$$

FACTOR DE SEGURIDAD ESTÁTICO - STATIC SAFETY FACTOR

La relación entre carga límite y carga máxima equivalente se define como coeficiente de seguridad estático:

The ratio between the maximum load and the maximum equivalent load is defined as static safety coefficient:

$$S_f = \frac{Q_0}{Q_{eq}} > 1$$

En base al ámbito de utilización del rodamiento, se aplican los siguientes factores de seguridad, con los cuales es posible efectuar una primera selección:

Considering the context in which the bearing will be used, it's possible to make a first selection applying the following safety values:

APLICACIÓN - APPLICATION	S_f
Posicionador soldadura - <i>Welding positioner</i> Plataforma aérea - <i>Aerial platform</i> Mesa giratoria - <i>Turntable</i> Radar (rotación lenta) - <i>Radar (slow rotation)</i> Carretilla elevadora - <i>Fork lift truck</i> Grúa de brazo - <i>Slewing crane</i>	1,35
Grúa de cuchara - <i>Grab crane</i> Grúa de gancho - <i>Heavy handling crane</i> Grúa de camión - <i>Truck crane</i> Grúa a bordo - <i>Ship crane</i> Grúa ferroviaria - <i>Railway crane</i>	1,5
Hormigoneras - <i>Concrete pump</i> Camión grúas telescópicos - <i>Telescopic mobile crane</i> Perforadora - <i>Bucket</i> Excavadora de cable - <i>Cable shovel</i> Excavadora de cuchara - <i>Grab shovel</i> Robótica - <i>Robotic</i> Grúa de torre (brazo giratorio) - <i>Tower crane (slewing jib)</i> Grúa de puerto - <i>Dock crane</i>	1,65
Compactadora - <i>Compactor</i> Grúa offshore - <i>Offshore crane</i> Grúa de torre (torre giratoria) - <i>Tower crane (slewing tower)</i>	1,8
Excavadora hidráulica - <i>Hydraulic shovel</i> Mezcladora de hormigón - <i>Concrete mixer</i> Generador eólico - <i>Windturbine</i> Radar (rotación rápida) - <i>Radar (rapid rotation)</i> Excavadora para minería - <i>Mine digging machine</i>	2

CÁLCULO DE RESISTENCIA DE LOS BULONES DE FIJACIÓN

FIXING BOLTS RESISTANCE CALCULATION

Ya que la función del rodamiento es la de permitir el movimiento de los elementos de la estructura en la cual está instalado y con la cual está conectado a través de una serie de elementos de fijación, la capacidad del sistema no puede prescindir de la verificación de la tornillería misma en las reales condiciones de trabajo.

Since the function of the bearing is to permit the relative rotation of the elements of the structure on which it has been installed and to which is linked through fixing elements, the capacity of the system depends on the verification of the bolts in real working conditions.

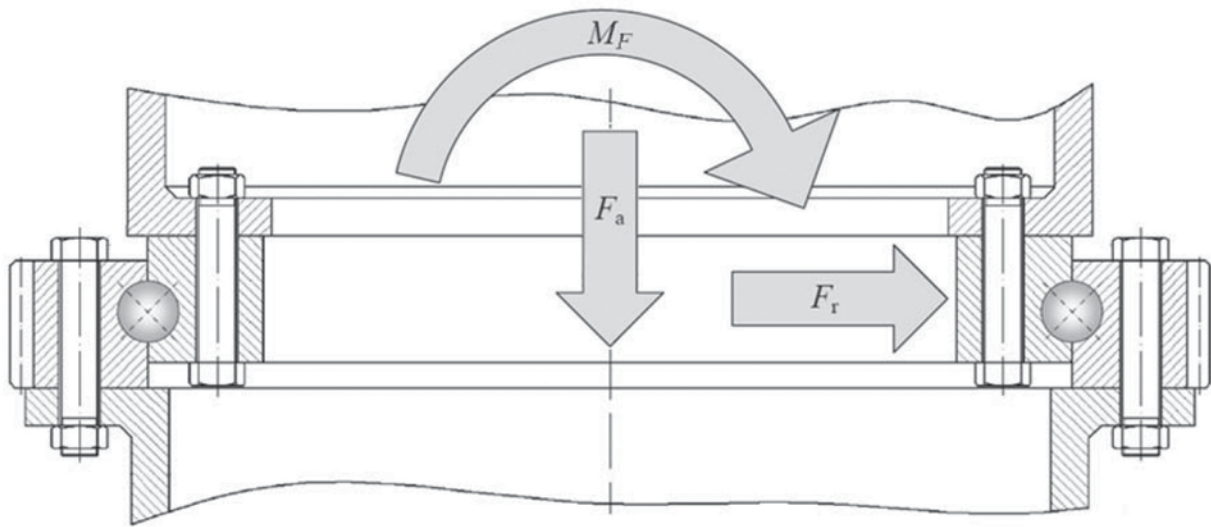

El control de los bulones se efectúa sobre la base de las especificaciones de la norma alemana VDI2230, la cual, en función del estado de carga del rodamiento y tomando en cuenta el comportamiento estático y dinámico de los bulones, define las cargas máximas de tracción sobre cada uno de los bulones.

En particular se controla que la pre-carga del bulón resulte suficiente para garantizar la resistencia del sistema de fijación bajo carga y que el bulón mismo pueda soportar la carga total aplicada.

The bolts verification is done according to the German standard VDI2230 which, in function of the load case of the bearing and considering the static and dynamic behavior of the bolts, leads to define the maximum tensile loads on the single bolt. In particular, it's verified that the preload on the single bolt is greater than the value required to ensure the integrity of the whole tightening system under loads, and it is also verified that the single bolt is able to resist to the total applied load.

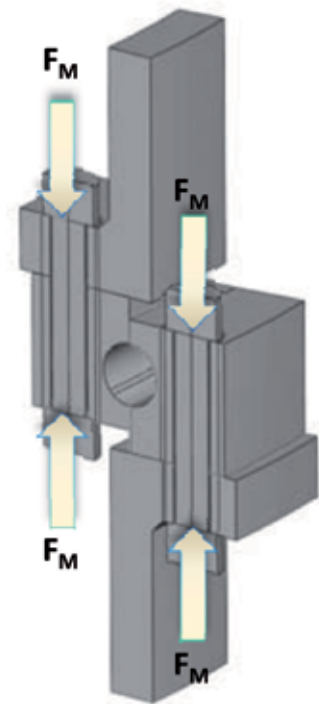

$$F_M > F_{MMax} = \alpha_A \cdot [F_{Kerf} + F_{PA} + F_Z]$$

$$F_{SA} < 0.1 \cdot R_{P0.2} \cdot A_S$$

F_M = Pre-carga del bulón - *Bolt preload*

F_{MMax} = Máxima pre-carga requerida - *Maximum preload required*

α_M = Factor de apriete - *Tightening factor*

F_{Kerf} = Mínima pre-carga para garantizar la sujeción del bulón
Minimum bolt preload required

$F_{PA} + F_Z$ = Reducción de la pre-carga de servicio
Loss of preload in service

F_{SA} = Fuerza(s) resultante(s) de la aplicación de la carga F_A
Resulting load from application force F_A

$R_{P0.2}$ = Carga de alargamiento del bulón
Bolt Yield strength

A_S = Área resistente del bulón
Cross section area under stress

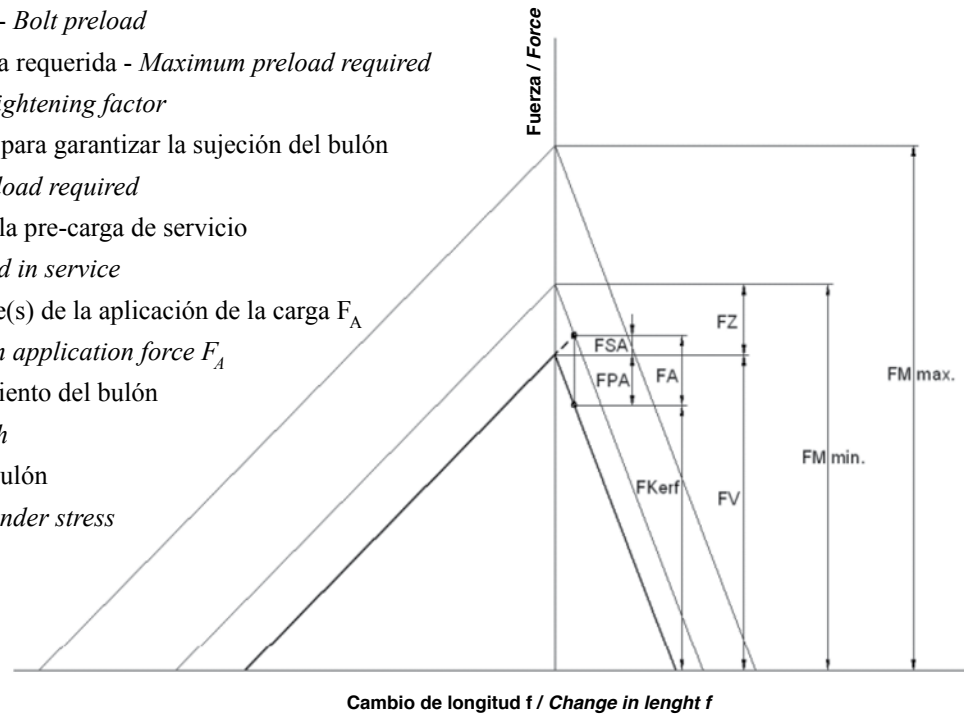

La pre-carga y el par de apriete del bulón se calculan del siguiente modo:

The preload and tightening torque of bolts are calculated as follows:

$$F_M = \sigma_M \cdot A_S$$

$$\sigma_M = \frac{v \cdot R_{P0.2}}{\sqrt{1+3 \left[\frac{4}{1+d_3/d_2} \left(\frac{P}{\pi \cdot d_2} + 1.155 \mu_G \right) \right]^2}}$$

σ_M = Esfuerzo medio de tracción en el bulón
Mean tensile stress of the bolt

v = Porcentaje de alargamiento de pre-carga
Degree of exploitation of the yield load during tightening

d_2 = Diámetro primitivo del bulón
Pitch diameter of the bolt

d_2 = Diámetro del núcleo de la rosca
Minor diameter of bolt thread

μ_G = Coeficiente de fricción de la rosca
Coefficient of friction in thread

$$M_A = F_M \left[0.16P + 0.58d_2\mu_G + \frac{D_{km}}{2} \mu_K \right]$$

$$D_{km}/2 = (d_w + d_h)/4$$

M_A = Par de apriete
Tightening torque

d_w = Diámetro exterior de contacto de la cabeza del bulón
Outer diameter of the plane head bearing surface

d_h = Diámetro de perforación de los elementos embulonados
Bore diameter of the clamped parts

μ_K = Coeficiente de fricción de la cabeza del bulón - superficie de contacto
Coefficient of friction for bolt head - contact surface

Consultar la parte 4 "Instalación y Mantenimiento" para conocer los valores de par de apriete y las instrucciones operativas de montaje.

Please check part 4 "Installation & Maintenance" for tightening torque values and installation operative instructions.

UTILIZACIÓN DEL DIAGRAMA DE CARGA - USE OF LOAD DIAGRAM

Si no se considera la componente radial del estado de carga del rodamiento es posible representar en un diagrama cartesiano, en cuyo eje X se expone el valor de la carga axial F_a y en el eje Y el par de vuelco M_f , las condiciones límite de funcionamiento, expresadas por la curva límite del rodamiento.

La curva de carga máxima admisible para una específica aplicación se obtiene transfiriendo la curva límite de una cantidad proporcional a su relativo factor de seguridad S_f (pág. 43).

According to the load equations, without considering the radial component of the load case of the bearing, it's possible to represent in a Cartesian diagram where X and Y axes represent respectively the axial load F_a and the tilting moment M_f , the working limit conditions, expressed by the survival curve.

The allowable load curve for a specific application is obtained from the translation of the survival load curve of a quantity proportional to its safety factor S_f (page 43).

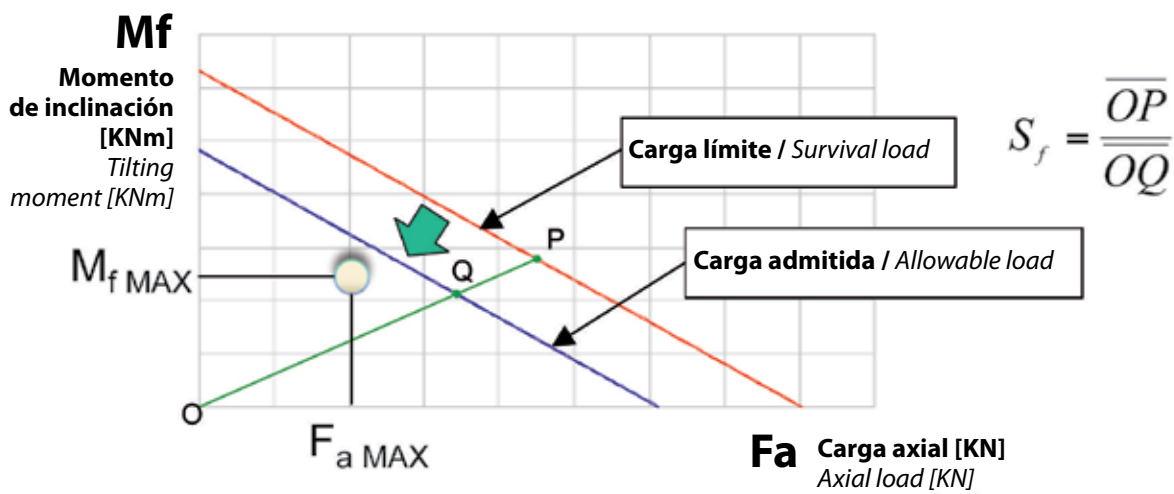

Lo dicho anteriormente equivale a considerar un incremento sobre las cargas incidentes sobre el rodamiento igual al **FACTOR DE SEGURIDAD S_f** , en modo tal que resulte posible utilizar fácilmente los gráficos.

*This is equivalent to consider an increase of the loads exactly equal to **SAFETY FACTOR S_f** , in order to simplify the use of load diagrams.*

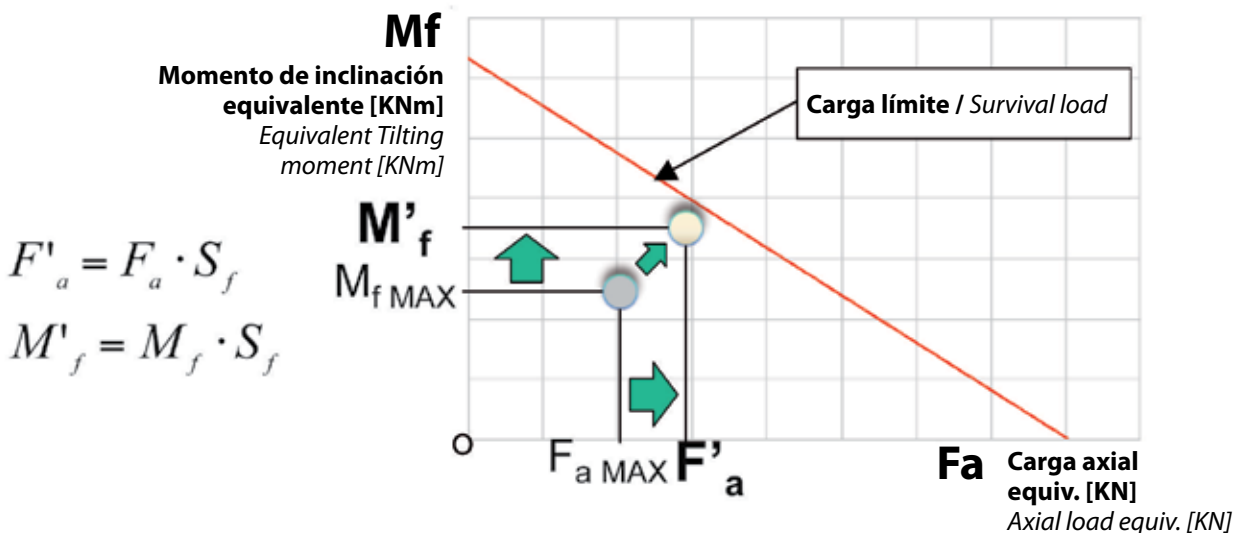

Resulta posible definir un gráfico análogo para la tornillería: también en este caso, volcando en el mismo diagrama cartesiano las condiciones límites de funcionamiento del sistema de fijación se obtiene una curva que tiene el siguiente desarrollo:

El diagrama tiene validez para fuerzas axiales F_a exclusivamente de compresión.

Para otras condiciones de carga contactar nuestra oficina técnica.

The same graph could be done for the bolts: also in this case, tracing the limit working conditions of the fixing system on the same Cartesian diagram, we obtain a curve similar to the following.

The diagram has validity only for compressive axial forces F_a .

For different load cases contact our technical office.

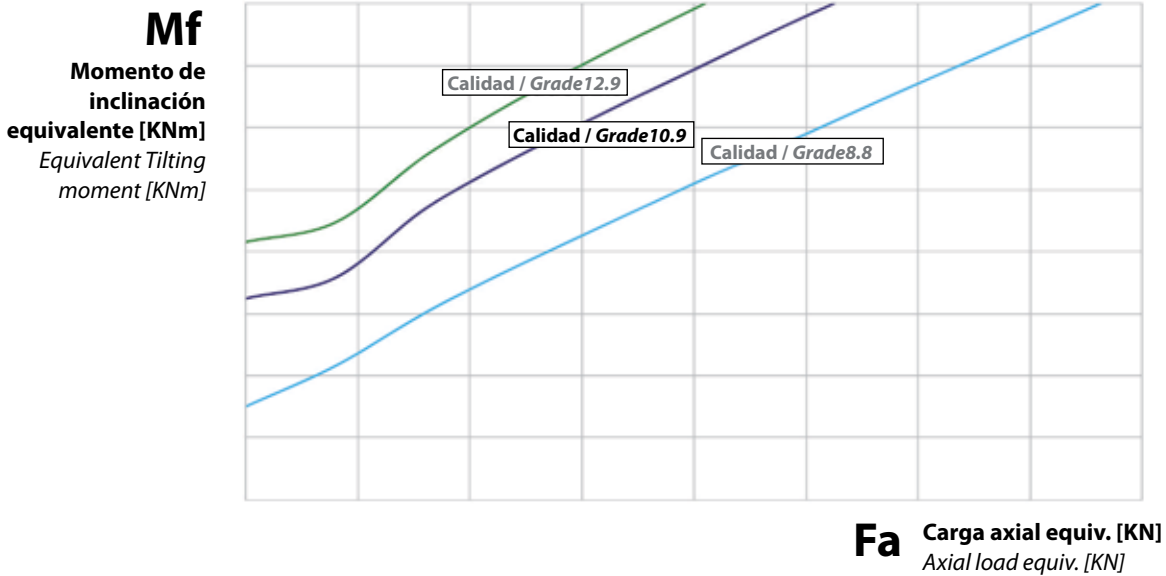

El área definida de las curvas límites representa la zona de funcionamiento del rodamiento.

The area defined by the limit curves is the working area of the bearing.

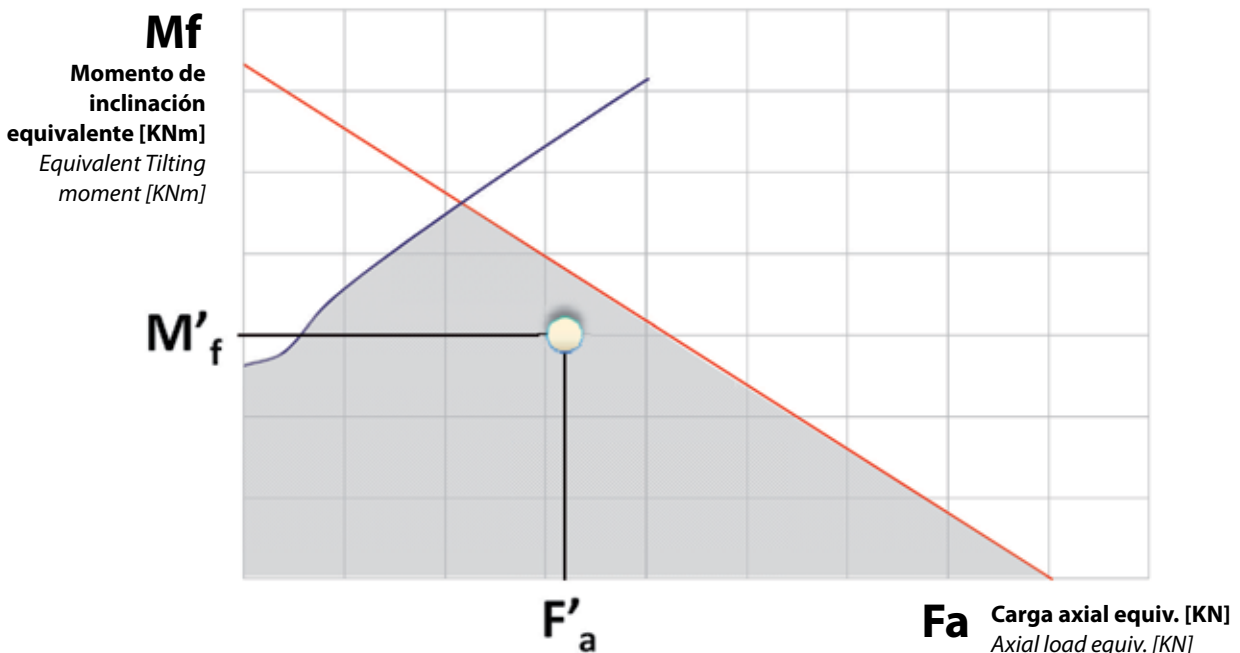

VERIFICACIÓN EN PRESENCIA DE CARGA RADIAL VERIFICATION IN PRESENCE OF RADIAL LOAD

En el caso que exista una carga radial F_r , es posible tenerla en cuenta aplicando las siguientes correcciones:

It's also possible to consider a radial load F_r just applying the following corrections:

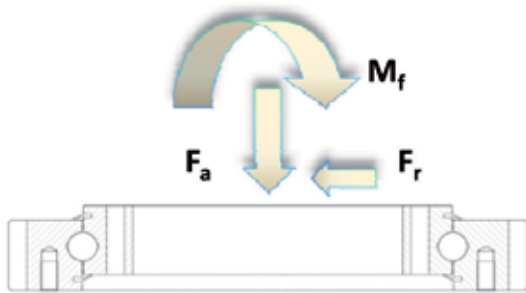

Rodamientos de bolas / Ball bearings:

$$a \begin{cases} F'_a = (F_a + 5,046 \cdot F_r) \cdot S_f \\ M'_f = M_f \cdot S_f \end{cases}$$

$$b \begin{cases} F''_a = (1,225 \cdot F_a + 2,676 \cdot F_r) \cdot S_f \\ M''_f = 1,225 \cdot M_f \cdot S_f \end{cases}$$

Rodamientos de rodillos cruzados / Cross roller bearings:

$$a \begin{cases} F'_a = (F_a + 2,05 \cdot F_r) \cdot S_f \\ M'_f = M_f \cdot S_f \end{cases}$$

En el caso de rodamientos de bolas, por lo menos una de las dos condiciones de carga equivalente deberá resultar inferior a la curva límite.

For ball bearings, at least one of the two equivalent loads cases has to be under the limit curve.

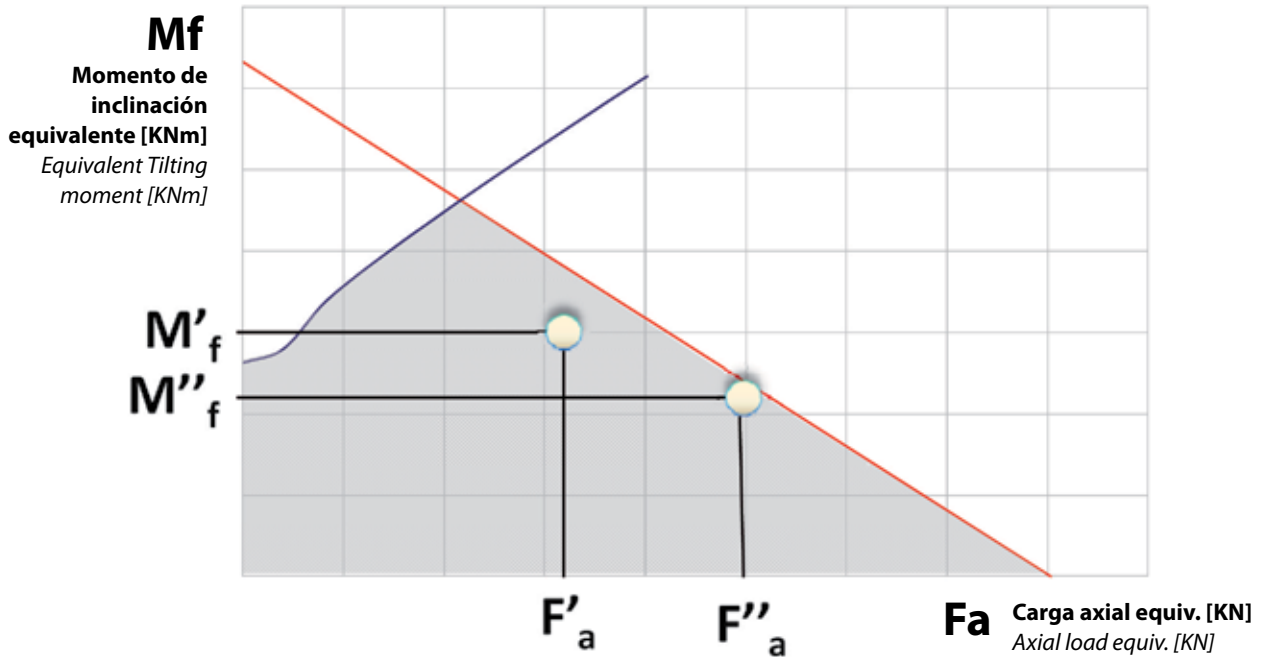

CÁLCULO DE LA VIDA ÚTIL A FATIGA - RATING LIFE CALCULATION

El análisis de la vida útil a fatiga de un rodamiento toma como referencia la norma ISO 281.

Un rodamiento en rotación sujeto a una carga puede presentar, si se lo ha dimensionado en modo erróneo, microdefectos bajo la forma de pequeñas fisuras o grietas bajo la superficie del camino de rodadura que a largo andar aumentan dando vida a una exfoliación del material ("pitting").

La probabilidad que aparezca este defecto en un grupo de rodamientos presenta una dispersión representable con el modelo de distribución de Weibull:

The analysis of the rating life of a bearing is based on the ISO 281 normative.

A rolling bearing subject to a certain load, if not correctly dimensioned, could have some micro-defects in terms of little fractures under the raceway surface which in the next could grow and cause the pitting of the materials.

The probability of this phenomena in a group of bearings could be estimated through the Weibull distribution:

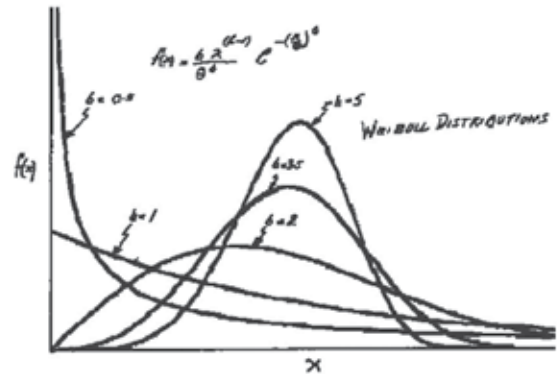

La vida útil a fatiga se define por lo tanto como el número de rotaciones (u horas de funcionamiento) que alcanza el 90% de los rodamientos (de un grupo de rodamientos idénticos entre sí) antes que se manifieste fatiga del material.

Rating life is defined as the number of rotations (working hours) reached by the 90% of the bearings (all the bearings are equal) before fatigue defect signals come out.

$$L_{10}[10^6 \text{ rev.}] = \left(\frac{C}{P}\right)^p \quad L_{10h}[\text{hours}] = \frac{L_{10}}{60 \cdot n}$$

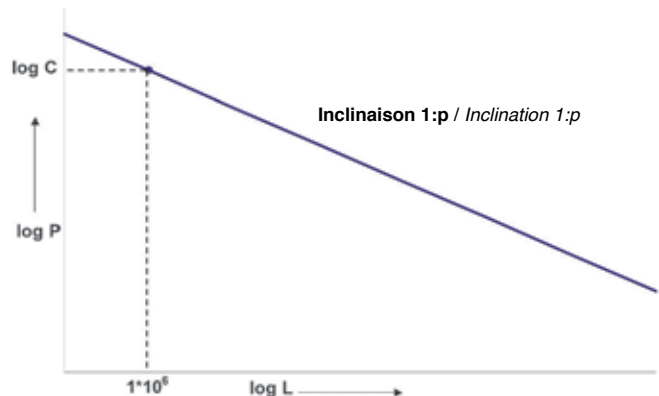

- **C** es el coeficiente de carga dinámica del rodamiento definido como coeficiente de carga básico supeditado a la geometría del rodamiento, al cual se aplican coeficientes de corrección que contemplan las características del material y las condiciones de trabajo.

- **C** is the dynamic working load coefficient of the bearing defined as the basic dynamic load coefficient depending on the bearing geometry, to which some adjustments are applied in order to consider the material features and the working conditions.

- **P** es la carga dinámica equivalente en función de las cargas incidentes sobre el rodamiento F_a , M_f e F_r .

- **P**, the dynamic equivalent load, is a function of the loads applied to the bearing F_a , M_f and F_r .

- **p** es un exponente equivalente a 3 para rodamientos de bola y a 10/3 para rodamientos de rodillos.

- **p** is a coefficient equal to 3 for balls bearings or to 10/3 for roller bearings.

Considerado un campo de carga con un número K de condiciones de carga, la vida útil del rodamiento puede ser calculada del siguiente modo:

Considering a general load condition with a K number of load cases, the bearing life is calculated as follows:

$$\frac{1}{L_{10}[10^6 \text{ rev.}]} = \sum_{i=0}^K \frac{f_{\%i}}{L_{10i}}$$

$f_{\%i}$ = Frecuencia de aplicación de la carga i (%)

Application frequency for load case i

L_{10i} = Vida útil a fatiga (10⁶ rev.) en la condición de carga i

Rating life (10⁶ rev.) for load case i

En función de las cargas incidentes, de su frecuencia de aplicación y de la velocidad de rotación **n** del rodamiento resulta por lo tanto posible estimar la vida útil a fatiga en términos de número de rotaciones (**Nrev**) o, análogamente, en numero de horas de funcionamiento (**Nh**).

Del mismo modo, una vez definida una duración de base requerida del rodamiento es posible exponer en el diagrama **M_f-F_a** la curva limite para un determinado numero de hileras de vida útil a fatiga (**Nrev**).

Depending on the load agents, their application frequency and the rotation speed *n* of the bearing, it is possible to estimate the fatigue life in terms of number of rotations (**Nrev**) or, similarly, in terms of number of operating hours (**Nh**).

In the same way, by defining a basic lifetime of the bearing, it is possible to trace on the diagram **M_f-F_a** the limit curve for a given number of turns of fatigue life (**Nrev**).

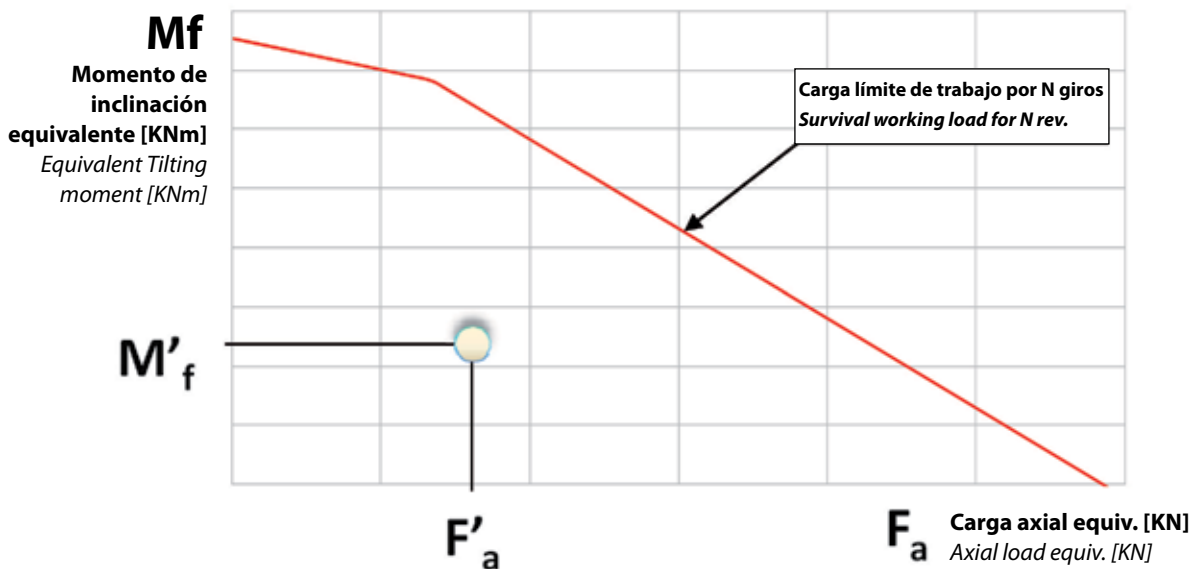

RESISTENCIA DEL DENTADO - GEAR RESISTANCE

La transmisión del movimiento entre las dos partes de la estructura sobre la cual se aplica el rodamiento la puede efectuar directamente el rodamiento mismo mediante engrane de uno de los aros dentados con un piñón vinculado con el segundo aro.

El piñón puede estar vinculado tanto a la parte giratoria como también a la parte fija y el dentado del rodamiento puede ser exterior o bien interior y se dimensiona oportunamente para soportar las sollicitaciones incidentes.

La geometría y las propiedades mecánicas del acoplamiento piñón-rodamiento se calculan sobre la base de las normas DIN vigentes.

The motion transmission between two parts of a structure could be done directly by the bearing through a toothed ring that engages a pinion moving together with the other ring. The pinion could be assembled to the fixed or to the mobile part of the structure, and the gear of the bearing could be external or internal, designed to resist to the load applied.

The geometry and the mechanical proprieties of the coupling pinion-bearing must be calculated basing on current DIN norms.

$$F_t = \frac{M_{t1}}{1/2 d_{p1}} = \frac{M_{t2}}{1/2 d_{p2}} < F_{t \text{ lim}} = \frac{\sigma \cdot m \cdot L}{Y_B \cdot Y_F \cdot Y_S (\cdot Y_E)}$$

$M_{t1/2}$ = Par de rotación en el piñón/rodamiento
Slewing torque on pinion/bearing

$d_{p1/2}$ = Diámetro primitivo del dentado del piñón/rodamiento
Pitch diameter of pinion/bearing toothing

σ = Esfuerzo límite de flexión del diente
Ultimate bending strength of tooth

m = Módulo del dentado
Toothing module

L = Ancho del dentado
Toothing width

Y_B, Y_F, Y_S, Y_E = Factores de reducción geométricos
Geometric scale-down factors

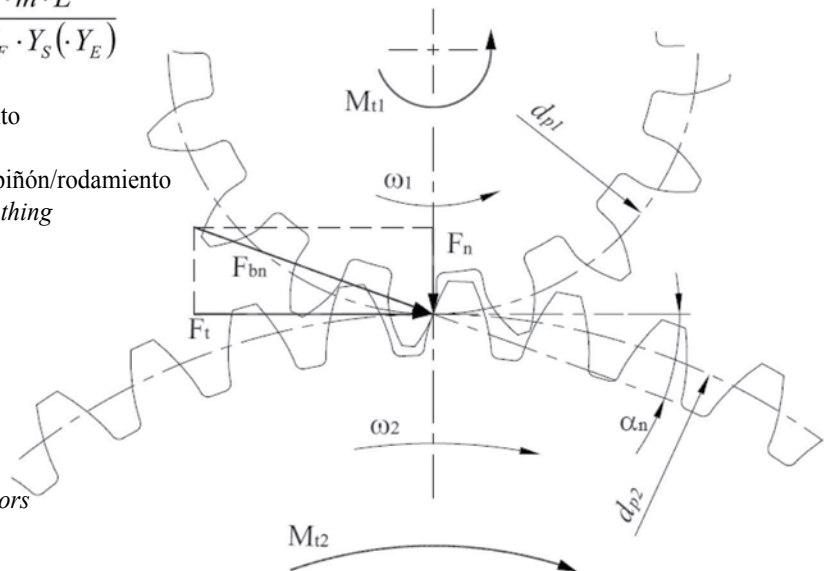

En las tablas se exponen dos valores de esfuerzos tangenciales en el diente, uno admisible **fz norm** y el otro límite **fz max**. El cálculo de la carga sobre el diente, efectuado en las condiciones de normal servicio no debe superar el valor de **fz norm**, en cambio el cálculo efectuado luego de condiciones excepcionales, como sobrecarga o bloqueo de la estructura no debe superar **fz max**.

*In the tables, two values of tangential load on the teeth are listed: the first is the admissible value called **fz norm**, the second is the limit value called **fz max**. The calculation of the tooth load performed on normal working conditions must not be over the value of **fz norm**, instead the calculation performed considering exceptional working conditions, such as overload or the locking of the structure, must not be over **fz max** value.*

PODEMOS BRINDARLES ASISTENCIA EN LA VERIFICACIÓN DEL ENGRANE, DEFINIENDO LOS VALORES DE CORRECCIÓN Y CORTE (Y POR LO TANTO EL INTEREJE) PARA EL PIÑÓN.
WE CAN SUPPORT YOU ON GEARING VERIFICATION, DEFINING CORRECTION AND TRUNCATION VALUES (SO AXIS DISTANCE) FOR THE PINION.

FRICCIÓN Y LUBRICACIÓN - FRICTION AND LUBRICATION

La resistencia que un rodamiento opone a la rotación de la estructura está fundamentalmente causada por la fricción rodante entre bolas o rodillos y el camino de rodadura de los aros además de una pequeña cota de fricción entre cuerpos rodantes y distanciadores.

El par de fricción de un rodamiento bajo carga se puede calcular con la siguiente relación:

The resistance a bearing shows during the structure rotation is determined by the friction between rollers and raceway, plus a small amount of friction between rollers and spacers.

The friction torque of a loaded bearing is well approximated by the following equation:

$$M_T = \frac{\mu}{2} \left(k \cdot M + |F_a| \cdot D_L + \frac{k \cdot F_r \cdot D_L \cdot f}{2} \right)$$

$k = 4.37$ (rodamiento de bolas) (*ball bearing*) - 4.1 (rodamiento de rodillos) (*roller bearing*)

$f = 1.73$ (rodamiento de bolas) (*ball bearing*) - 1 (rodamiento de rodillos) (*roller bearing*)

$\mu = 0.006$ (rodamiento de una hilera de bolas) (*single row balls bearing*)

$\mu = 0.009$ (rodamiento de dos hileras de bolas) (*double row balls bearing*)

$\mu = 0.004$ (rodamiento de rodillos) (*roller bearing*)

La relación semi-empírica expuesta tiene validez para un rodamiento bien lubricado. Una lubricación continua y completa del camino de rodadura resulta en efecto un punto fundamental para garantizar la necesaria durabilidad del rodamiento.

El lubricante actúa idealmente en dos modos, creando una película sutil que evita el contacto directo y la adhesión de las superficies a contacto y disminuye la fricción mediante una consecuente disminución del esfuerzo tangencial en la zona de contacto.

Dicho comportamiento, válido para rodamientos en rotación continua, se denomina lubricación hidrodinámica y depende sustancialmente de la geometría de los sólidos a contacto y de la viscosidad del lubricante y de la velocidad de rotación.

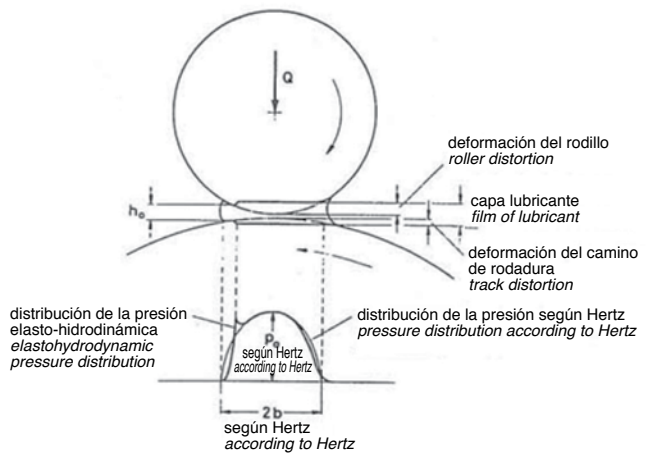

The semi empirical relation above is valid for a well-lubricated bearing. A continuous and complete lubrication is in fact a fundamental factor that guarantees the required lifetime of the bearing. The lubricant operates in two ways: it creates a thin film that prevents direct contact and adhesion of surfaces, and it reduces the roller friction through a corresponding decrease in the tangential stress in the contact area.

This behavior, valid for bearings in continuous rotation, is called hydrodynamic lubrication and largely depends on the geometry of contact elements, the lubricant viscosity, and the rotation speed.

La viscosidad de base del lubricante se calcula en función del diametro de rodadura del rodamiento y de su velocidad de rotación en base al siguiente diagrama:

The viscosity of the lubricant base is then calculated according to the rolling diameter of the bearing and its rotational speed according to the following diagram:

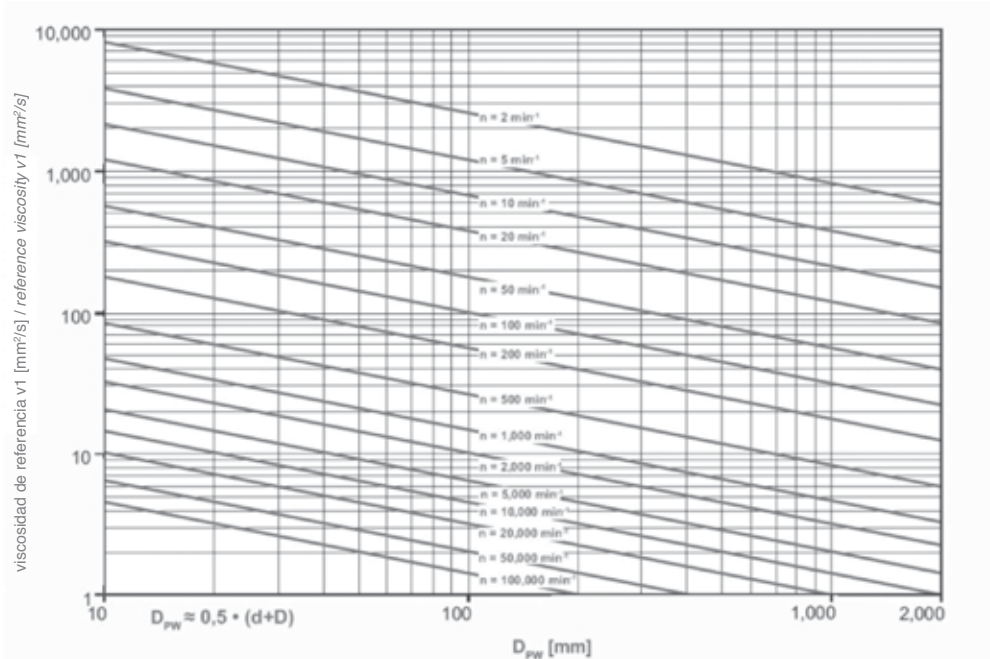

Nota la temperatura de trabajo del rodamiento T_L hace posible conocer, a través del diagrama v-T :la viscosidad efectiva del lubricante:

Note the temperature of T_L from the diagram v-T is possible to set the effective viscosity of the lubricant:

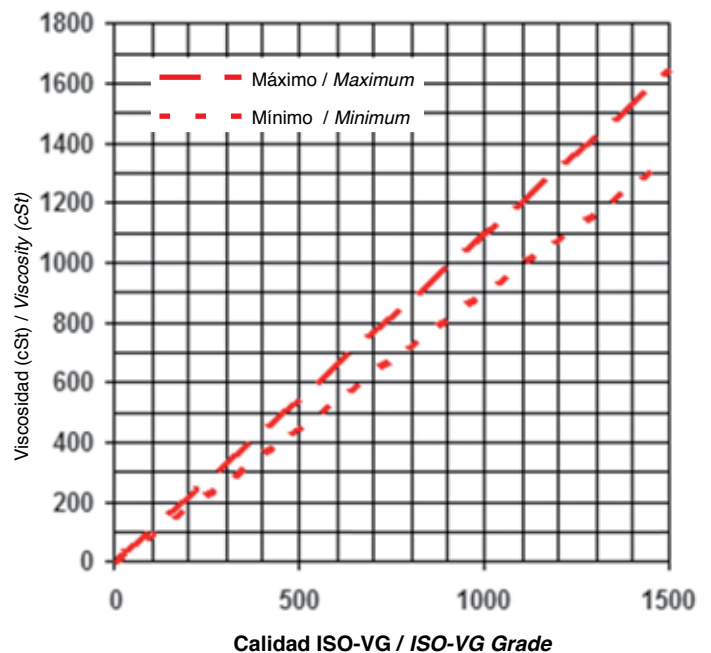
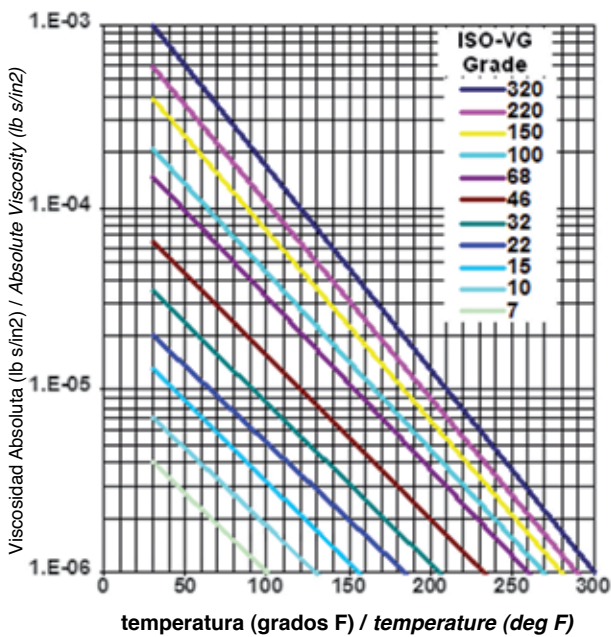



PARTE 3 - CATÁLOGO GENERAL CORONA GIRATORIA

PART 3 - GENERAL SLEWING BEARING CATALOGUE

SERIE LIGERA / LIGHT SERIES

ZK SERIES pag. 58
Dentada interior / Int. toothed



NK SERIES pag. 59
No dentada / Untoothed



SERIE CON BRIDAS / FLANGED SERIES

EBL SERIES pag. 61
Dentada exterior / Ext. toothed



EBL.20 S
EBL.20 P
EBL.30 S
EBL.30 P

ZBL SERIES pag. 67
Dentada interior / Int. toothed



ZBL.20 S
ZBL.20 P
ZBL.30 S
ZBL.30 P

NBL SERIES pag. 73
No dentada / Untoothed



NBL.20 S
NBL.20 P
NBL.30 S
NBL.30 P

SERIE ESTÁNDAR DE UNA HILERA DE BOLAS ONE ROW BALL STANDARD SERIES

EB1 SERIES pag. 79
Dentada exterior / Ext. toothed

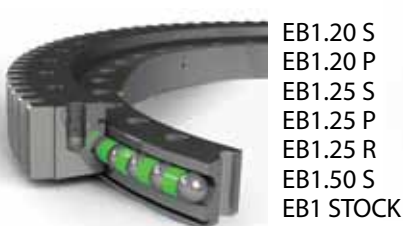

EB1.20 S
EB1.20 P
EB1.25 S
EB1.25 P
EB1.25 R
EB1.50 S
EB1 STOCK

ZB1 SERIES pag. 89
Dentada interior / Int. toothed



ZB1.20 S
ZB1.20 P
ZB1.25 S
ZB1.25 P
ZB1.25 R
ZB1.50 S
ZB1 STOCK

NB1 SERIES pag. 101
No dentada / Untoothed



NB1.20 S
NB1.20 P
NB1.25 S
NB1.25 P
NB1 STOCK

SERIE ESTÁNDAR DE DOS HILERAS DE BOLAS DOUBLE ROW BALL STANDARD SERIES

EB2 SERIES pag. 111
Dentada exterior / Ext. toothed



ZB2 SERIES pag. 115
Dentada interior / Int. toothed



TIPOLOGÍAS/ SERIES OVERVIEW

SERIE DE UNA HILERA DE RODILLOS CRUZADOS ONE ROW CROSSED ROLLER SERIES

ER1 SERIES pag. 119
Dentada exterior / *Ext. toothed*



ER1.14 S
ER1.14 PR
ER1.16 S
ER1.20/30
ER1.36/50

ZR1 SERIES pag. 125
Dentada interior / *Int. toothed*



ZR1.14 S
ZR1.14 PR
ZR1.16 S
ZR1.16/25
ZR1.30/50

NR1 SERIES pag. 131
No dentada / *Untoothed*



NR1.14 S
NR1.14 PR
NR1.16 S

SERIE DE TRES HILERAS DE RODILLOS TRIPLE ROW ROLLER SERIES

ER3 SERIES pag. 135
Dentada exterior / *Ext. toothed*



ER3.20/25
ER3.32/40

ZR3 SERIES pag. 139
Dentada interior / *Int. toothed*



ZR3.20/25
ZR3.32/40

SERIE DE RODILLOS CRUZADOS PARA ROTACIÓN DE PRECISIÓN CROSSED ROLLER SERIES FOR PRECISION ROTATION

CRBH, RB, SX SERIES pag. 143



RB
RE
RU
CRB(C)
CRBH
SX

SERIE DE PRECISIÓN PARA MESAS GIRATORIAS TURNABLE PRECISION SERIES

YRT, YRTS, ZKLDF SERIES pag. 153

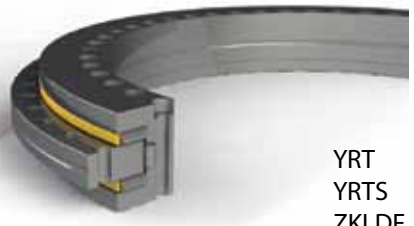

YRT
YRTS
ZKLDF

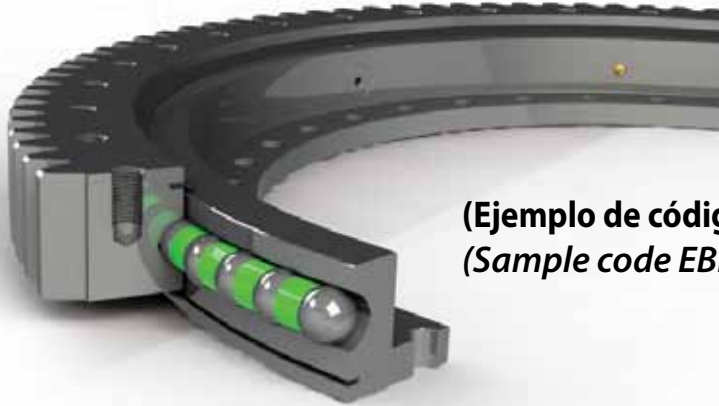

(Ejemplo de código EBL.30.1155.200 -1STPN)
(Sample code EBL.30.1155.200 -1STPN)

SERIE	DIÁMETRO RODILLO/BOLA	DIAMETRO DE RODADURA	MATERIAL ANILLOS	ÍNDICE	JUEGOS	TEMPLE DIENTES	PERFORACIÓN EXT-INT	PROTECCIÓN SUPERFICIAL	
SERIES	BALL/ROLLER DIAMETER	RACEWAY DIAMETER	RINGS MATERIAL	INDEX	CLEARANCES	GEAR HARDENING	FIXING HOLES EXT-INT	SURFACES PROTECTION	
EBL	30	1155	2	00	-	1	S	TP	N
ZR1	20		1	01		1	S	TT	N
ER3	25		2	02		2	F	PP	V
ZB2	30		3	...		3	R	PT	Z
...	...		4	...		4		TP	

NOTAS DE LA CODIFICACIÓN / DESIGNATION LEGENDA

TIPO DE DENTADO (PREFIJO) GEAR TYPE (PREFIX)		JUEGOS CLEARANCES		TEMPLE INDUCCIÓN DE LOS DIENTES INDUCTION TEETH HARDENING	
E	Exterior / External	1	Estándar / Standard	S	Ninguno / None
Z	Interior / Internal	2	Precisión / Precision	F	Sólo lado / Only flank
N	Ninguno / None	3	Ligera pre-carga Light preload	R	Lado y fondo Flank and root
TIPO DE DENTADO (PREFIJO) GEAR TYPE (PREFIX)		MATERIAL AROS RINGS MATERIAL		PERFORACIÓN EXT-INT FIXING HOLES EXT-INT	
K	Ligero una hilera de bolas Light profile, one row of balls	1	C45 Normalizado Normalized	P	Orificios pasantes estándares Through passing holes
BL	Con brida una hilera de bolas Flanged one row of balls	2	C45 Bonificado Quenched & Tempered	T	Orificio roscado Threaded holes
B	De Bolas With balls	3	42CrMo4 Normalizado Normalized	PROTECCIÓN SUPERFICIAL SURFACES PROTECTION	
R	De Rodillos With rollers	4	42CrMo4 Bonificado Quenched & Tempered	N	Aceitado / Oil coating
Nº HILERAS ELEMENTOS RODANTES ROLLING ROWS NUMBER				V	Pintado / Painting
1	Una hilera / One row			Z	Galvanizado / Zinc Coating
2	Dos hileras / Double row				
3	Tres hileras / Triple row				



Coronas giratorias serie ligera de una hilera de bolas

Light series one row ball bearings

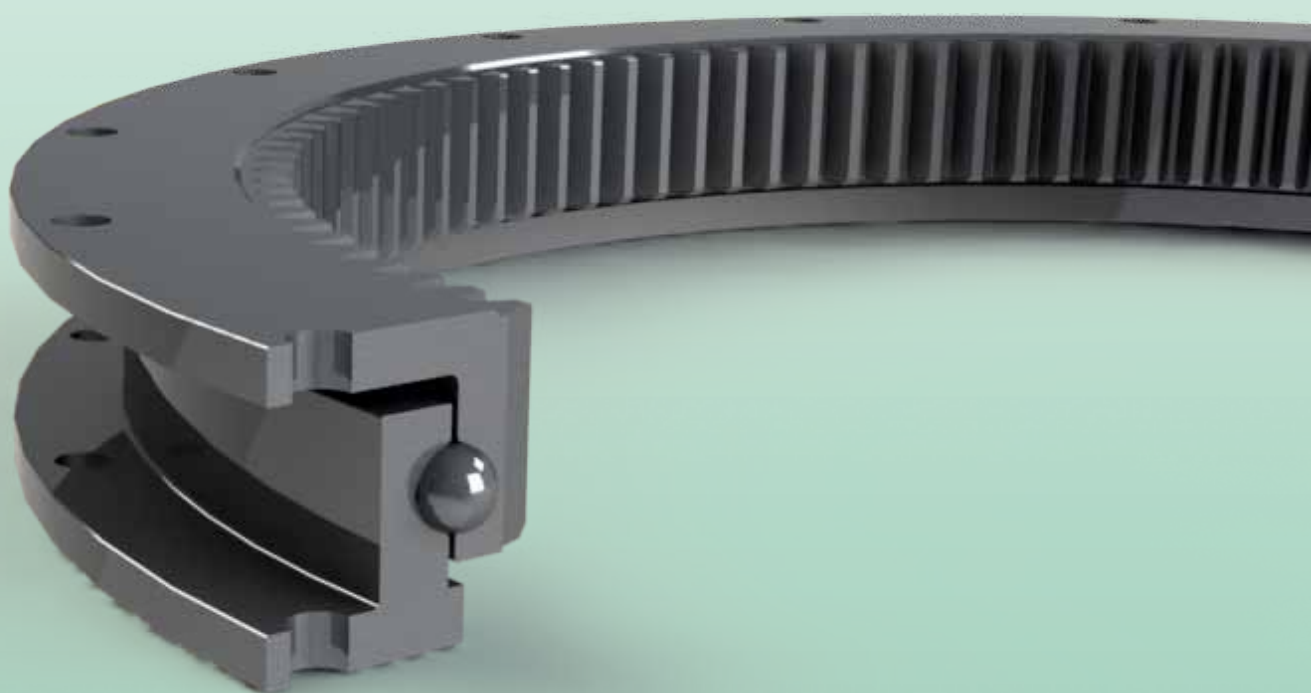

ZK/NK SERIES

ZK

SERIE LIGERA DENTADA, CON O SIN PERFORACIÓN

TOOTHED LIGHT SERIES, WITH OR WITHOUT FIXING HOLES

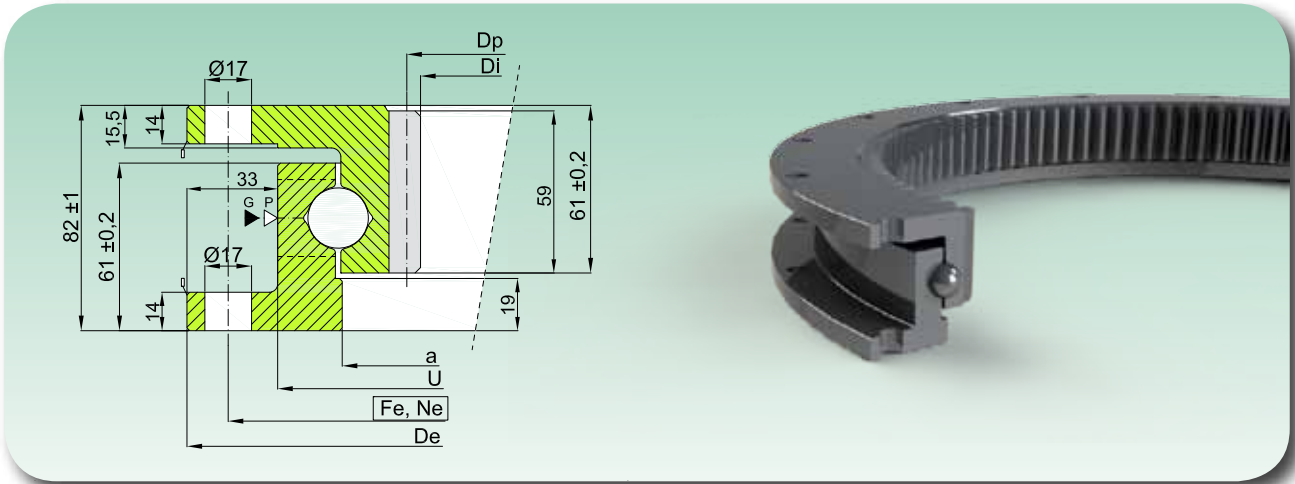

Curva Curve	ZK Código - Code		Dimensiones Dimensions				Perforación Fixing holes		Dentado Gear data					Peso Weight [kg]	
	CON PERFORACIÓN WITH FIXING HOLES	SIN PERFORACIÓN WITHOUT FIXING HOLES	De [mm]	U [mm]	a [mm]	Di [mm]	Fe [mm]	Ne [-]	m [mm]	Z [-]	xm [mm]	Dp [mm]	fz norm [kN]		fz max [kN]
2	ZK.22.0500.100-1SPPN	ZK.22.0500.100-1SN	498	432	384	331	470	16	5	68	-	340	11,3	22,6	37
3	ZK.22.0700.100-1SPPN	ZK.22.0700.100-1SN	700	634	584	530	670	24	5	108	-	540	11,3	22,6	59
4	ZK.22.0800.100-1SPPN	ZK.22.0800.100-1SN	804	738	689	636	774	30	6	108	+1	648	16,3	32,6	67
5	ZK.22.0880.100-1SPPN	ZK.22.0880.100-1SN	880	814	764	708	850	36	6	120	-	720	16,3	32,6	75
6	ZK.22.1000.100-1SPPN	ZK.22.1000.100-1SN	1000	934	884	830	970	36	6	140	-1	840	16,3	32,6	86
7	ZK.22.1100.100-1SPPN	ZK.22.1100.100-1SN	1095	1029	979	924	1065	36	6	156	-	936	16,3	32,6	96

- Material: C45 nor - Material C45 nor
 - Juego axial máx. 0,35 mm - Juego radial máx. 0,25 mm - Axial clearance max. 0,35 mm - Radial clearance max. 0,25 mm
 - Llenos de grasa, protegidos por aceite y envueltos en resistente película plástica - Full of grease, protected by oil and wrapped in resistant plastic film
 ▷ P=tapón inserción bolas / filling plug ▶ G= n.2 engrasadores M8X1 / n.2 greasers M8X1

Mf
Momento de inclinación equivalente [KNm]
Equivalent Tilting moment [KNm]



DIAGRAMA DE CARGA ESTÁTICA PARA ESFUERZOS DE COMPRESIÓN

STATIC LOAD CHARTS VALID FOR COMPRESSIVE LOADS

Fa
Carga axial equivalente [KN]
Equivalent axial load [KN]

Leer las instrucciones técnicas - parte 2 - para la utilización correcta del gráfico

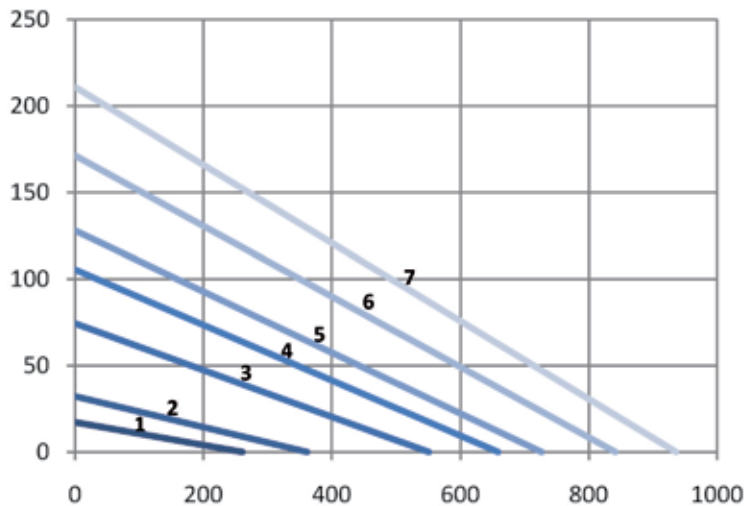
Please read technical instruction part 2 for correct use of load graph.

NK

SERIE LIGERA NO DENTADA, CON O SIN PERFORACIÓN

UNTOOTHED LIGHT SERIES, WITH OR WITHOUT FIXING HOLES

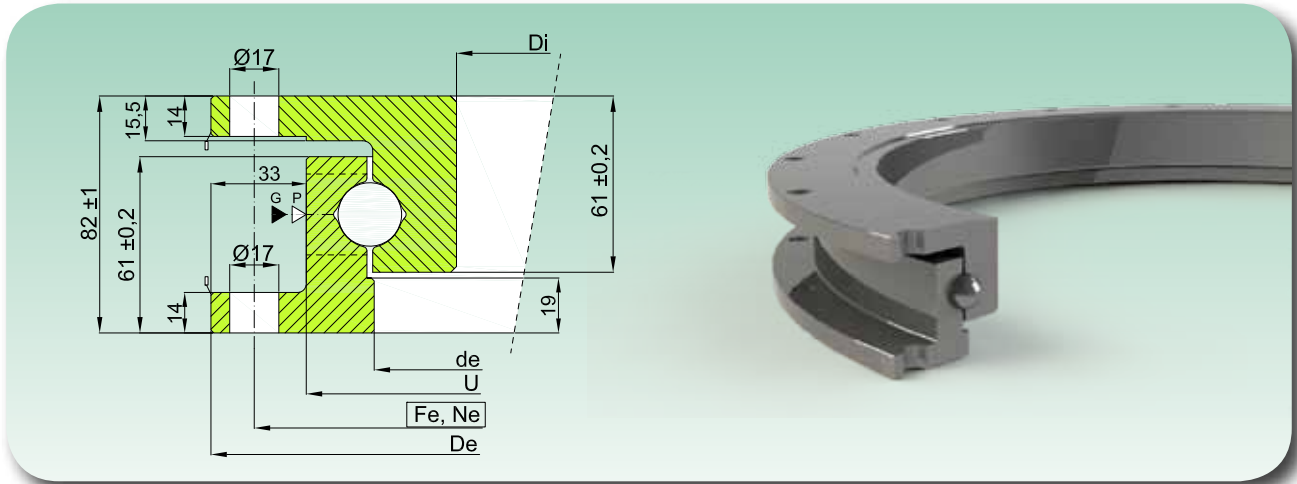

Curva Curve	NK Código - Code		Dimensiones Dimensions				Perforación Fixing holes		Peso Weight [kg]
	CON PERFORACIÓN WITH FIXING HOLES	SIN PERFORACIÓN WITHOUT FIXING HOLES	De [mm]	U [mm]	a [mm]	Di [mm]	Fe [mm]	Ne [-]	
1	NK.22.0400.100-1PPN ⁽¹⁾	NK.22.0400.100-1N ⁽¹⁾	400	351	310	280	376	24	22
2	NK.22.0500.100-1PPN	NK.22.0500.100-1N	498	432	384	331	470	16	39
3	NK.22.0700.100-1PPN	NK.22.0700.100-1N	700	634	584	530	670	24	61
4	NK.22.0800.100-1PPN	NK.22.0800.100-1N	804	738	689	636	774	30	69
5	NK.22.0880.100-1PPN	NK.22.0880.100-1N	880	814	764	708	850	36	77
6	NK.22.1000.100-1PPN	NK.22.1000.100-1N	1000	934	884	830	970	36	88
7	NK.22.1100.100-1PPN	NK.22.1100.100-1N	1095	1029	979	924	1065	36	98

⁽¹⁾ Altura rodamiento giratorio / Bearing height: 69mm
Orificios / Holes: Ø13mm

- Material: C45 nor
- Juego axial máx. 0,35 mm - Juego radial máx. 0,25 mm
- Llenos de grasa, protegidos por aceite y envueltos en resistente película plástica
▷ P=tapón inserción bolas / filling plug ▶ G= n.2 engrasadores M8X1 / n.2 greasers M8X1

- Material C45 nor
- Axial clearance max. 0,35 mm - Radial clearance max. 0,25 mm
- Full of grease, protected by oil and wrapped in resistant plastic film

Mf
Momento de inclinación equivalente [KNm]
Equivalent Tilting moment [KNm]



DIAGRAMA DE CARGA ESTÁTICA PARA ESFUERZOS DE COMPRESIÓN

STATIC LOAD CHARTS VALID FOR COMPRESSIVE LOADS

Fa

Carga axial equivalente [KN]
Equivalent axial load [KN]

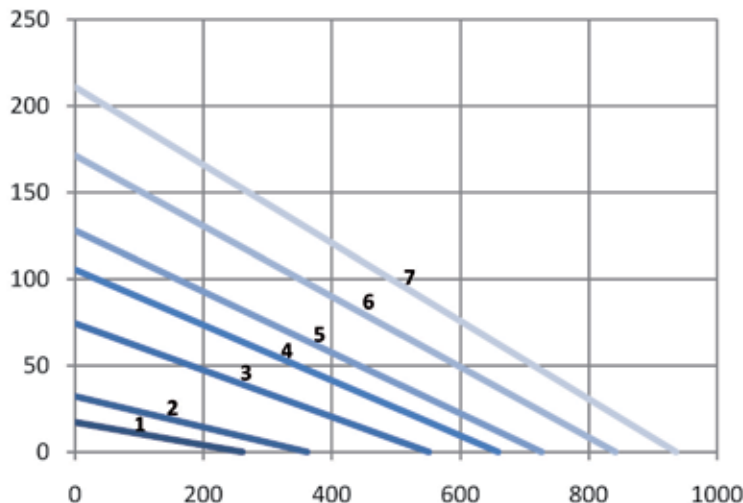
Leer las instrucciones técnicas - parte 2 - para la utilización correcta del gráfico

Please read technical instruction part 2 for correct use of load graph.





Coronas giratorias con bridas de una hilera de bolas, dentado exterior

One row ball flanged bearing, external toothed

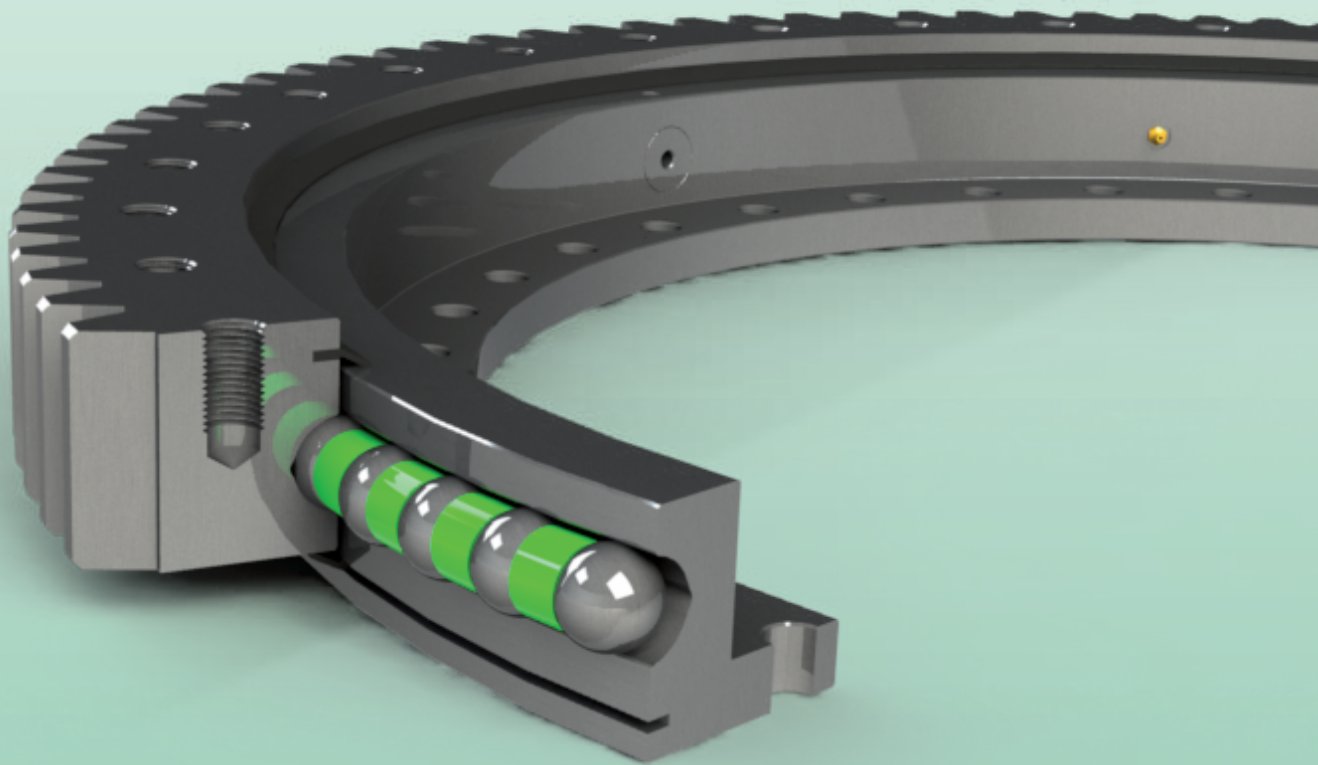

EBL SERIES

EBL.20 S

SERIE CON BRIDAS ESTÁNDAR

FLANGED STANDARD SERIES

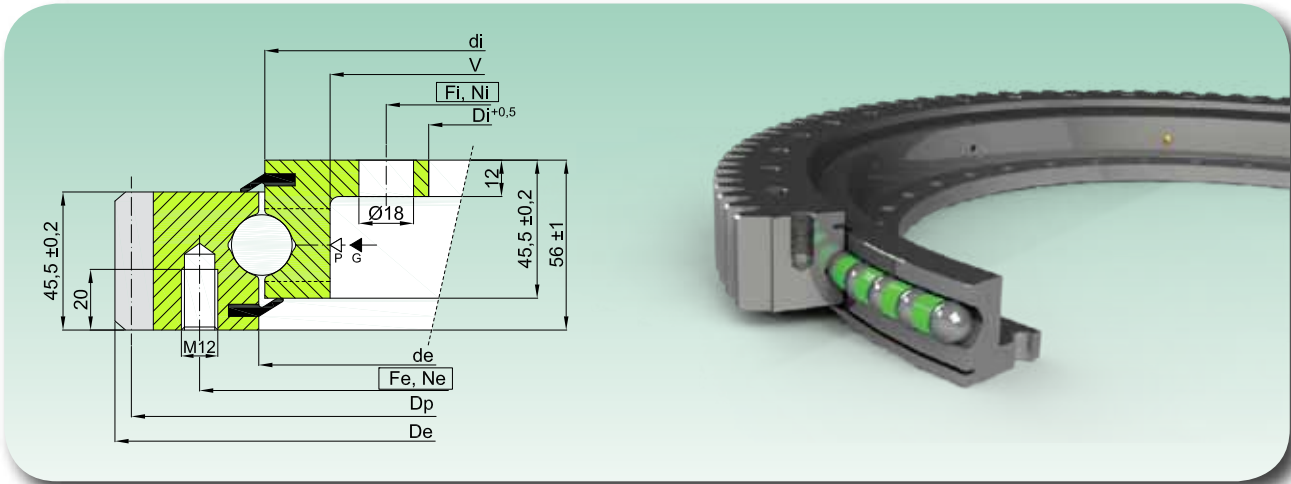

Código Code	Curva Curve	Dimensiones Dimensions					Orificios de fijación Fixing Holes				Dentado Gear data					Peso Weight [kg]
		De [mm]	de [mm]	di [mm]	V [mm]	Di [mm]	Fe [mm]	Ne [-]	Fi [mm]	Ni [-]	m [mm]	Z [-]	Dp [mm]	fz norm [kN]	fz max [kN]	
EBL.20.0314.200 -1STPN	1	404	315,5	312,5	269	204	355	10	232	12	5	79	395	14,96	29,92	23
EBL.20.0414.200 -1STPN	2	504	415,5	412,5	369	304	455	10	332	12	5	99	495	14,96	29,92	30
EBL.20.0544.200 -1STPN	3	640,8	545,5	542,5	499	434	585	14	462	14	6	105	630	17,95	35,9	42
EBL.20.0644.200 -1STPN	4	742,8	645,5	642,5	599	534	685	16	562	16	6	122	732	17,95	35,9	53
EBL.20.0744.200 -1STPN	5	838,8	745,5	742,5	699	634	785	18	662	16	6	138	828	17,95	35,9	56
EBL.20.0844.200 -1STPN	6	950,4	845,5	842,5	799	734	885	18	762	18	8	117	936	23,94	47,87	68
EBL.20.0944.200 -1STPN	7	1046,4	945,5	942,5	899	834	985	20	862	20	8	129	1032	23,94	47,87	75
EBL.20.1094.200 -1STPN	8	1198,4	1095,5	1092,5	1049	984	1135	22	1012	20	8	148	1184	23,94	47,87	87

- Material: C45Q+T

- Juego axial máx. 0,35 mm - Juego radial máx. 0,25 mm

- Llenos de grasa, protegidos por aceite y envueltos en resistente película plástica

▷ P=tapón inserción bolas / filling plug

- Material C45 Q+T

- Axial clearance max. 0,35 mm - Radial clearance max. 0,25 mm

- Full of grease, protected by oil and wrapped in resistant plastic film

▶ G=n.4 engrasadores M8X1 / n.4 greasers M8X1

Mf
Momento de inclinación equivalente [KNm]
Equivalent Tilting moment [KNm]



DIAGRAMA DE CARGA ESTÁTICA PARA ESFUERZOS DE COMPRESIÓN

STATIC LOAD CHARTS VALID FOR COMPRESSIVE LOADS

Fa
Carga axial equivalente [KN]
Equivalent axial load [KN]

Leer las instrucciones técnicas - parte 2 - para la utilización correcta del gráfico

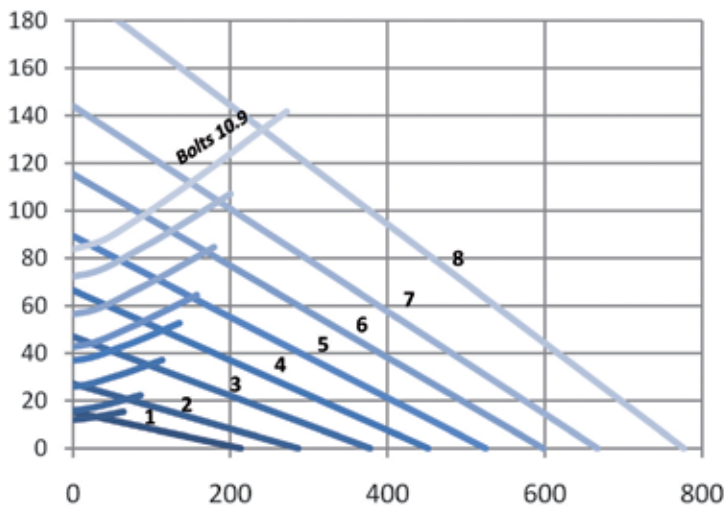
Please read technical instruction part 2 for correct use of load graph.

EBL.20 P

SERIE CON BRIDAS, DE PRECISIÓN

FLANGED PRECISION SERIES

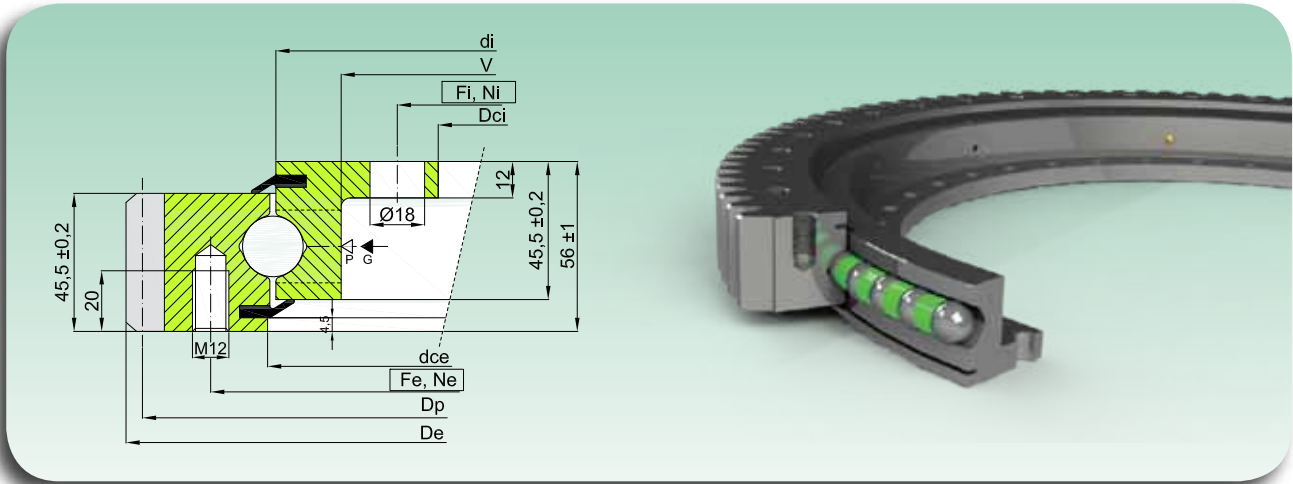

Código Code	Curva Curve	Dimensiones Dimensions					Orificios de fijación Fixing Holes				Dentado Gear data				Juego ax. y radial Axial and Radial Clearance	Peso Weight	
		De	dce	di	V	Dci	Fe	Ne	Fi	Ni	m	Z	Dp	fz norm			fz max
		[mm]	[mm]	[mm]	[mm]	[mm]	[mm]	[-]	[mm]	[-]	[mm]	[-]	[mm]	[kN]	[kN]	[kg]	[kg]
EBL.20.0314.201-2STPN	1	404	317 +0,09	312,5	269	205 +0,07	355	10	232	12	5	79	395	14,96	29,92	0 ÷ 0,03	23
EBL.20.0414.201-2STPN	2	504	417 +0,10	412,5	369	305 +0,09	455	10	332	12	5	99	495	14,96	29,92	0 ÷ 0,03	30
EBL.20.0544.201-2STPN	3	640,8	547 +0,11	542,5	499	435 +0,10	585	14	462	14	6	105	630	17,95	35,9	0 ÷ 0,03	42
EBL.20.0644.201-2STPN	4	742,8	647 +0,13	642,5	599	535 +0,11	685	16	562	16	6	122	732	17,95	35,9	0 ÷ 0,04	53
EBL.20.0744.201-2STPN	5	838,8	747 +0,13	742,5	699	635 +0,13	785	18	662	16	6	138	828	17,95	35,9	0 ÷ 0,04	56
EBL.20.0844.201-2STPN	6	950,4	847 +0,14	842,5	799	735 +0,13	885	18	762	18	8	117	936	23,94	47,87	0 ÷ 0,05	68
EBL.20.0944.201-2STPN	7	1046,4	947 +0,14	942,5	899	835 +0,14	985	20	862	20	8	129	1032	23,94	47,87	0 ÷ 0,05	75
EBL.20.1094.201-2STPN	8	1198,4	1097 +0,17	1092,5	1049	985 +0,17	1135	22	1012	20	8	148	1184	23,94	47,87	0 ÷ 0,06	87

- Material: C45Q+T

- Material C45 Q+T

- Llenos de grasa, protegidos por aceite y envueltos en resistente película plástica

- Full of grease, protected by oil and wrapped in resistant plastic film

▷ P=tapón inserción bolas / filling plug

▶ G= n.4 engrasadores M8X1 / n.4 greasers M8X1

Mf
Momento de inclinación equivalente [KNm]
Equivalent Tilting moment [KNm]



DIAGRAMA DE CARGA ESTÁTICA PARA ESFUERZOS DE COMPRESIÓN

STATIC LOAD CHARTS VALID FOR COMPRESSIVE LOADS

Fa

Carga axial equivalente [KN]
Equivalent axial load [KN]

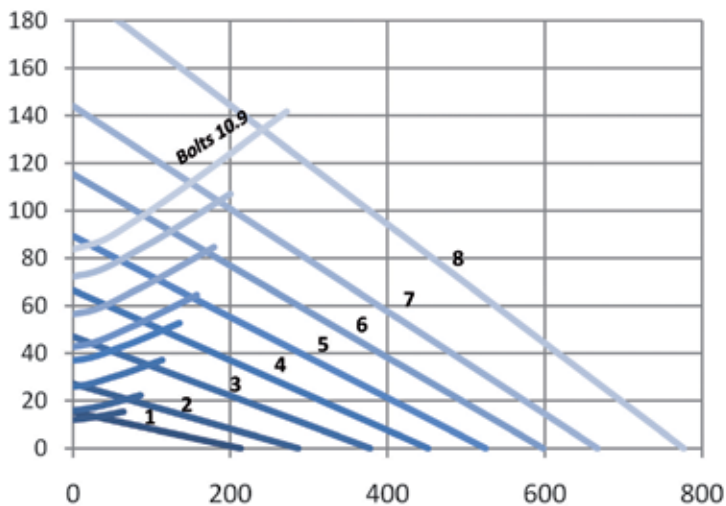
Leer las instrucciones técnicas - parte 2 - para la utilización correcta del gráfico

Please read technical instruction part 2 for correct use of load graph.

EBL.30 S

SERIE CON BRIDAS ESTÁNDAR

FLANGED STANDARD SERIES

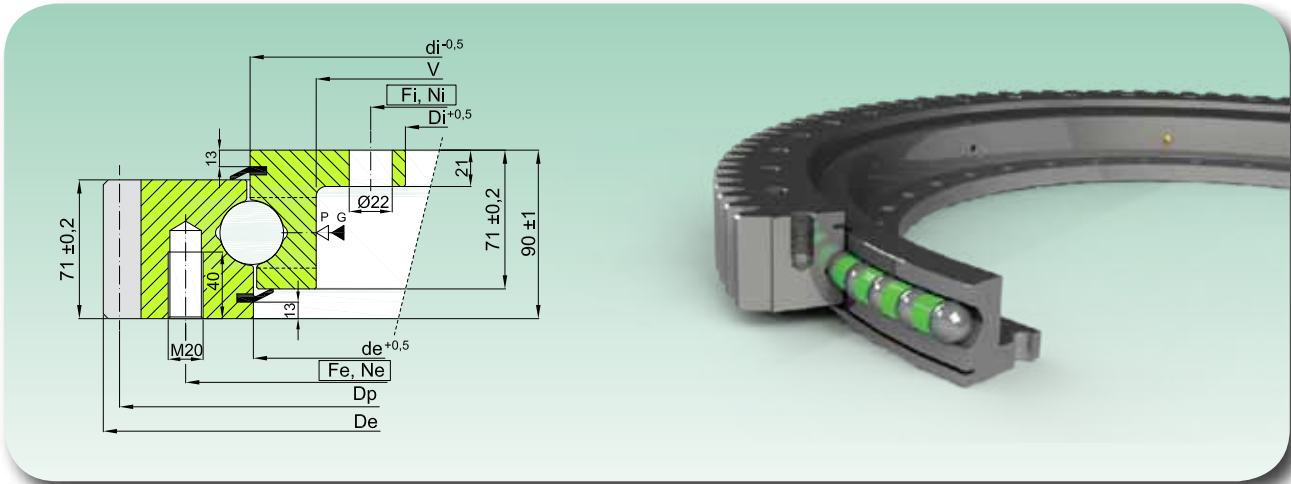

Código Code	Curva Curve	Dimensiones Dimensions					Orificios de fijación Fixing Holes				Dentado Gear data				Peso Weight [kg]	
		De [mm]	de [mm]	di [mm]	V [mm]	Di [mm]	Fe [mm]	Ne [-]	Fi [mm]	Ni [-]	m [mm]	Z [-]	Dp [mm]	fz norm [kN]		fz max [kN]
EBL.20.0414.200-1STPN	1	1096	953,5	956,5	893	805	1016	30	845	30	9	120	1080	43,45	86,9	165
EBL.30.1055.200-1STPN	2	1198	1053,5	1056,5	993	905	1116	30	945	30	10	118	1180	48,28	96,56	183
EBL.30.1155.200-1STPN	3	1298	1153,5	1156,5	1093	1005	1216	36	1045	36	10	128	1280	48,28	96,56	200
EBL.30.1255.200-1STPN	4	1398	1253,5	1256,5	1193	1105	1316	42	1145	42	10	138	1380	48,28	96,56	216
EBL.30.1355.200-1STPN	5	1498	1353,5	1356,5	1293	1205	1416	42	1245	42	10	148	1480	48,28	96,56	234
EBL.30.1455.200-1STPN	6	1598	1453,5	1456,5	1393	1305	1516	48	1345	48	10	158	1580	48,28	96,56	250

- Material: C45Q+T - Material C45 Q+T
 - Juego axial máx. 0,40 mm - Juego radial máx. 0,30 mm - Axial clearance max. 0,40 mm - Radial clearance max. 0,30 mm
 - Llenos de grasa, protegidos por aceite y envueltos en resistente película plástica - Full of grease, protected by oil and wrapped in resistant plastic film
 ▷ P=tapón inserción bolas / filling plug ▶ G= n.6 engrasadores M8X1 / n.6 greasers M8X1

Mf
Momento de inclinación equivalente [KNm]
Equivalent Tilting moment [KNm]



DIAGRAMA DE CARGA ESTÁTICA PARA ESFUERZOS DE COMPRESIÓN

STATIC LOAD CHARTS VALID FOR COMPRESSIVE LOADS

Fa
Carga axial equivalente [KN]
Equivalent axial load [KN]

Leer las instrucciones técnicas - parte 2 - para la utilización correcta del gráfico

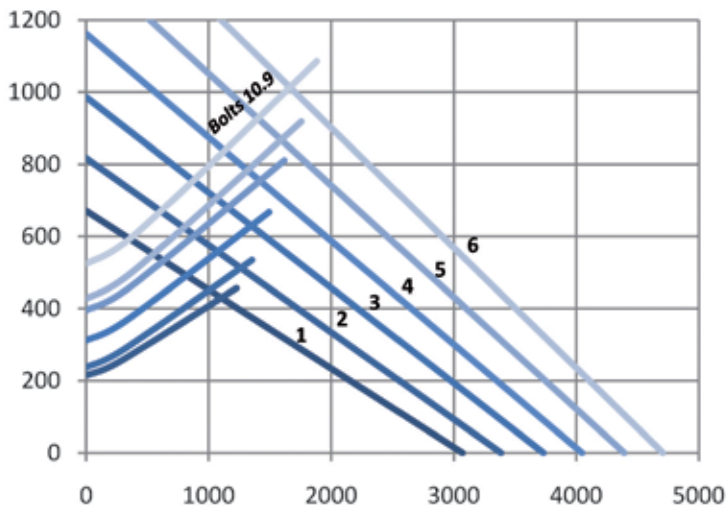
Please read technical instruction part 2 for correct use of load graph.

EBL.30 P

SERIE CON BRIDAS, DE PRECISIÓN

FLANGED PRECISION SERIES

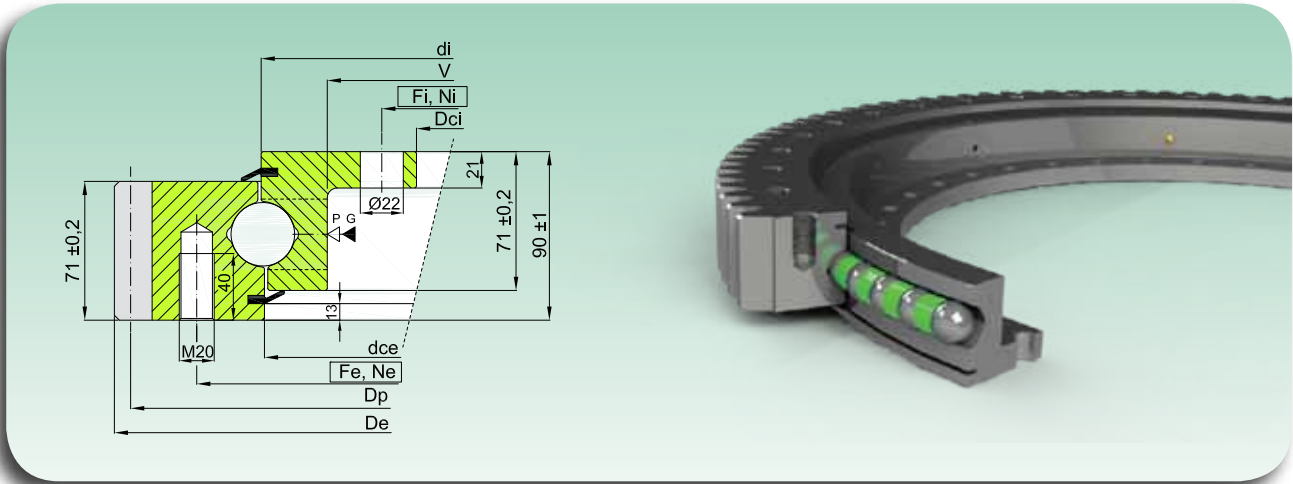

Código Code	Curva Curve	Dimensiones Dimensions					Orificios de fijación Fixing Holes				Dentado Gear data					Juego ax. y radial Axial and Radial Clearance	Peso Weight
		De	dce	di	V	Dci	Fe	Ne	Fi	Ni	m	Z	Dp	fz norm	fz max		
		[mm]	[mm]	[mm]	[mm]	[mm]	[mm]	[-]	[mm]	[-]	[mm]	[-]	[mm]	[kN]	[kN]		
EBL.20.0314.201-2STPN	1	1096	955 +0,14	956,5	893	807 +0,14	1016	30	845	30	9	120	1080	43,45	86,9	0 ÷ 0,06	165
EBL.30.1055.201-2STPN	2	1198	1055 +0,14	1056,5	993	907 +0,14	1116	30	945	30	10	118	1180	48,28	96,56	0 ÷ 0,06	183
EBL.30.1155.201-2STPN	3	1298	1155 +0,17	1156,5	1093	1007 +0,17	1216	36	1045	36	10	128	1280	48,28	96,56	0 ÷ 0,06	200
EBL.30.1255.201-2STPN	4	1398	1255 +0,17	1256,5	1193	1107 +0,17	1316	42	1145	42	10	138	1380	48,28	96,56	0 ÷ 0,07	216
EBL.30.1355.201-2STPN	5	1498	1355 +0,17	1356,5	1293	1207 +0,17	1416	42	1245	42	10	148	1480	48,28	96,56	0 ÷ 0,07	234
EBL.30.1455.201-2STPN	6	1598	1455 +0,20	1456,5	1393	1307 +0,20	1516	48	1345	48	10	158	1580	48,28	96,56	0 ÷ 0,07	250

- Material: C45Q+T

- Material C45 Q+T

- Llenos de grasa, protegidos por aceite y envueltos en resistente película plástica

- Full of grease, protected by oil and wrapped in resistant plastic film

▷ P=tapón inserción bolas / filling plug

▶ G= n.6 engrasadores M8X1 / n.6 greasers M8X1

Mf
Momento de inclinación equivalente [KNm]
Equivalent Tilting moment [KNm]



DIAGRAMA DE CARGA ESTÁTICA PARA ESFUERZOS DE COMPRESIÓN

STATIC LOAD CHARTS VALID FOR COMPRESSIVE LOADS

Fa

Carga axial equivalente [KN]
Equivalent axial load [KN]

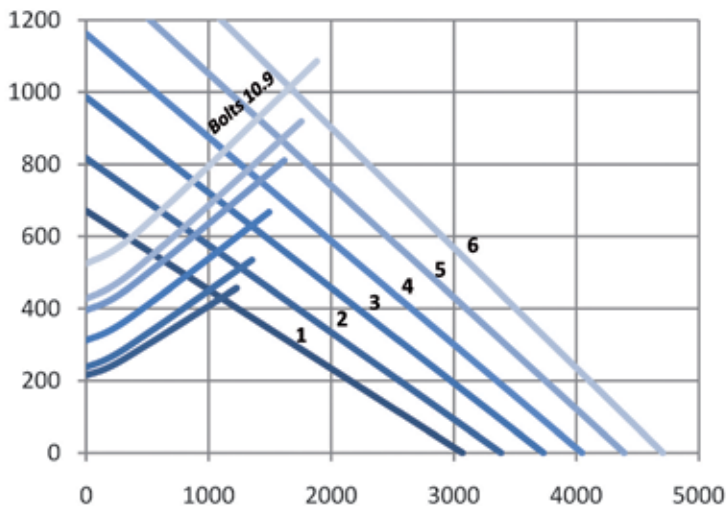
Leer las instrucciones técnicas - parte 2 - para la utilización correcta del gráfico

Please read technical instruction part 2 for correct use of load graph.





Coronas giratorias con bridas de una hilera de bolas, dentado interior

One row ball flanged bearing, internal toothed

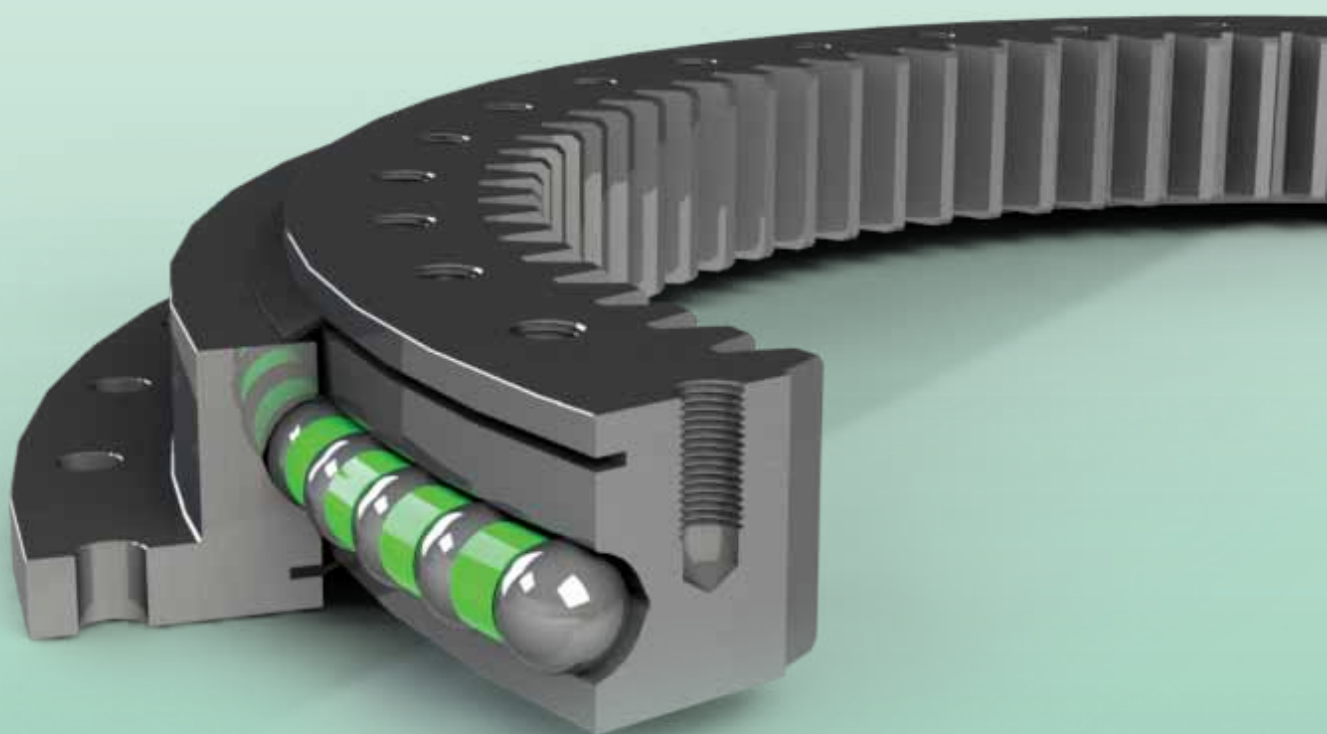

ZBL SERIES

ZBL.20 S

SERIE CON BRIDAS ESTÁNDAR

FLANGED STANDARD SERIES

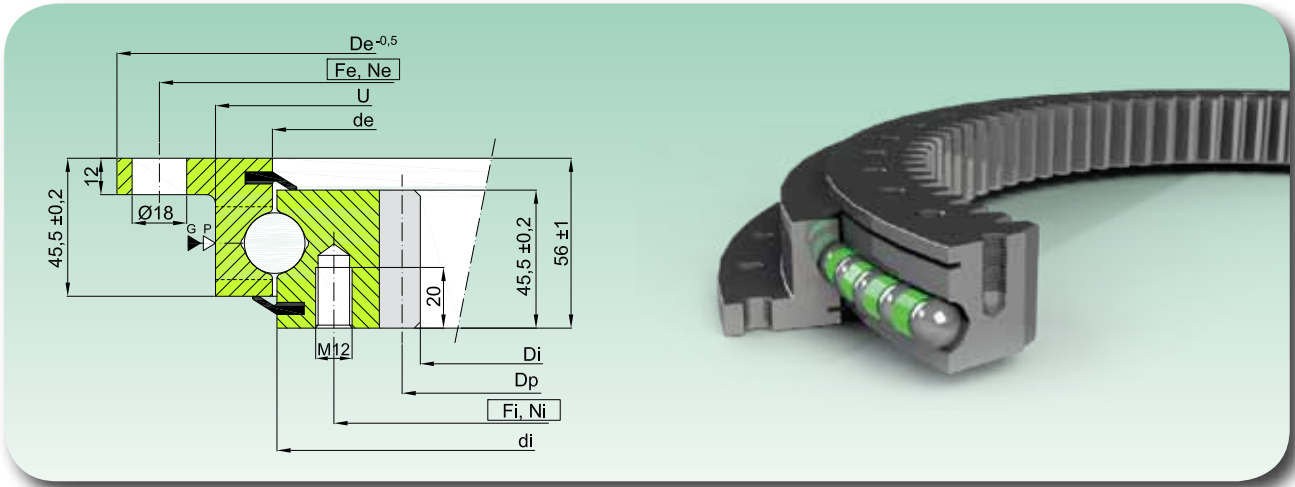

Código Code	Curva Curve	Dimensiones Dimensions					Orificios de fijación Fixing Holes					Dentado Gear data				Peso Weight [kg]
		De [mm]	U [mm]	de [mm]	di [mm]	Di [mm]	Fe [mm]	Ne [-]	Fi [mm]	Ni [-]	m [mm]	Z [-]	Dp [mm]	fz norm [kN]	fz max [kN]	
ZBL.20.0314.200 -1SPTN	1	418	353	315,5	312,5	225	390	8	275	12	5	47	235	15,58	31,17	21
ZBL.20.0414.200 -1SPTN	2	518	453	415,5	412,5	325	490	8	375	12	5	67	335	15,58	31,17	28
ZBL.20.0544.200 -1SPTN	3	648	583	545,5	542,5	444	620	10	505	16	6	76	456	18,7	37,4	39
ZBL.20.0644.200 -1SPTN	4	748	683	645,5	642,5	546	720	12	605	18	6	93	558	18,7	37,4	46
ZBL.20.0744.200 -1SPTN	5	848	783	745,5	742,5	648	820	12	705	20	6	110	660	18,7	37,4	52
ZBL.20.0844.200 -1SPTN	6	948	883	845,5	842,5	736	920	14	805	20	8	94	752	24,93	49,87	63
ZBL.20.0944.200 -1SPTN	7	1048	983	945,5	942,5	840	1020	16	905	22	8	107	856	24,93	49,87	69
ZBL.20.1094.200 -1SPTN	8	1198	1133	1095,5	1092,5	984	1170	16	1055	24	8	125	1000	24,93	49,87	83

- Material: C45Q+T
 - Juego axial máx. 0,35 mm - Juego radial máx. 0,25 mm
 - Llenos de grasa, protegidos por aceite y envueltos en resistente película plástica
 ▷ P=tapón inserción bolas / filling plug ▶ G=n.4 engrasadores M8X1 / n.4 greasers M8X1

- Material C45 Q+T
 - Axial clearance max. 0,35 mm - Radial clearance max. 0,25 mm
 - Full of grease, protected by oil and wrapped in resistant plastic film

Mf
Momento de inclinación equivalente [KNm]
Equivalent Tilting moment [KNm]



DIAGRAMA DE CARGA ESTÁTICA PARA ESFUERZOS DE COMPRESIÓN

STATIC LOAD CHARTS VALID FOR COMPRESSIVE LOADS

Fa
Carga axial equivalente [KN]
Equivalent axial load [KN]

Leer las instrucciones técnicas - parte 2 - para la utilización correcta del gráfico

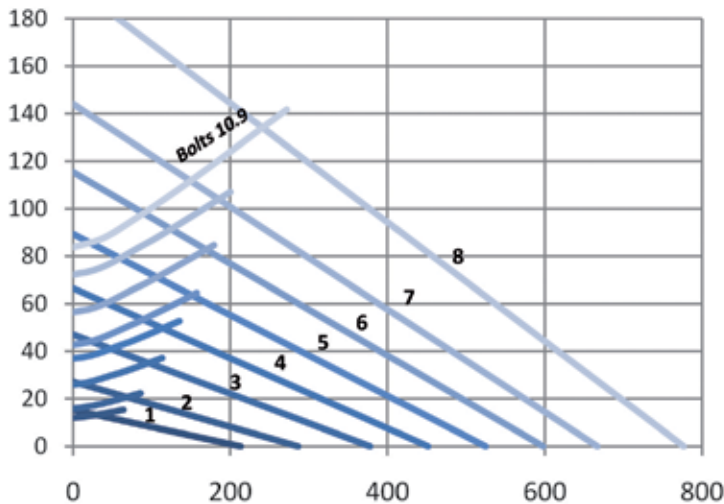
Please read technical instruction part 2 for correct use of load graph.

ZBL.20 P

SERIE CON BRIDAS, DE PRECISIÓN

FLANGED PRECISION SERIES

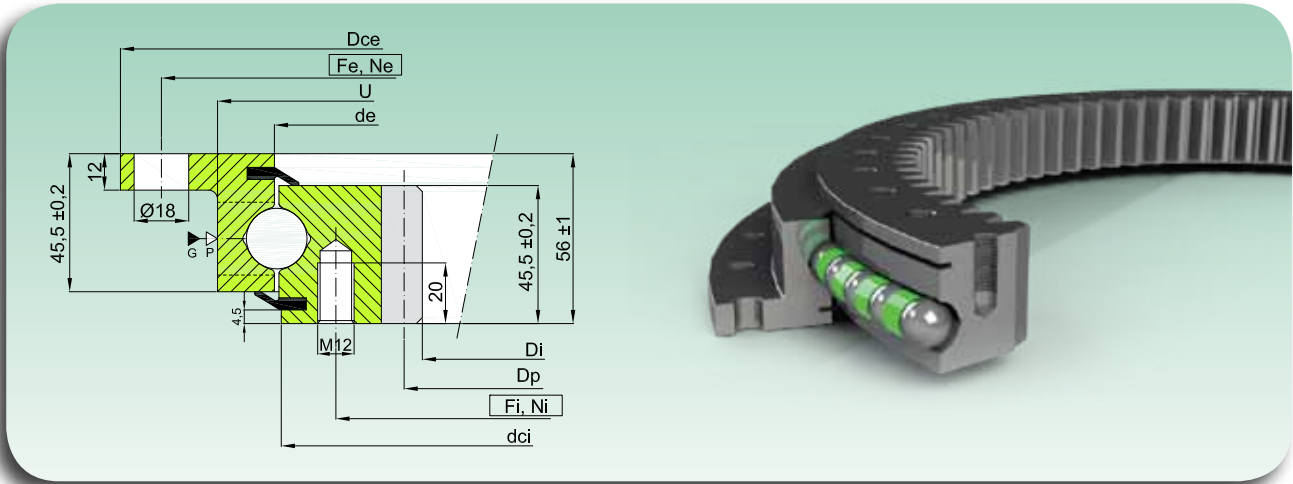

Código Code	Curva Curve	Dimensiones Dimensions				Orificios de fijación Fixing Holes				Dentado Gear data				Juego ax. y radial Axial and Radial Clearance	Peso Weight		
		Dce [mm]	U [mm]	de [mm]	dci [mm]	Di [mm]	Fe [mm]	Ne [-]	Fi [mm]	Ni [-]	m [mm]	Z [-]	Dp [mm]			fz norm [kN]	fz max [kN]
ZBL.20.0314.201-2SPTN	1	417 -0,10	353	315,5	311 -0,09	225	390	8	275	12	5	47	235	15,58	31,17	0 ÷ 0,03	21
ZBL.20.0414.201-2SPTN	2	517 -0,11	453	415,5	411 -0,10	325	490	8	375	12	5	67	335	15,58	31,17	0 ÷ 0,03	28
ZBL.20.0544.201-2SPTN	3	647 -0,13	583	545,5	541 -0,11	444	620	10	505	16	6	76	456	18,7	37,4	0 ÷ 0,03	39
ZBL.20.0644.201-2SPTN	4	747 -0,13	683	645,5	641 -0,13	546	720	12	605	18	6	93	558	18,7	37,4	0 ÷ 0,04	46
ZBL.20.0744.201-2SPTN	5	847 -0,14	783	745,5	741 -0,13	648	820	12	705	20	6	110	660	18,7	37,4	0 ÷ 0,04	52
ZBL.20.0844.201-2SPTN	6	947 -0,14	883	845,5	841 -0,14	736	920	14	805	20	8	94	752	24,93	49,87	0 ÷ 0,05	63
ZBL.20.0944.201-2SPTN	7	1047 -0,17	983	945,5	941 -0,14	840	1020	16	905	22	8	107	856	24,93	49,87	0 ÷ 0,05	69
ZBL.20.1094.201-2SPTN	8	1197 -0,17	1133	1095,5	1091 -0,17	984	1170	16	1055	24	8	125	1000	24,93	49,87	0 ÷ 0,06	83

- Material: C45Q+T

- Material C45 Q+T

- Llenos de grasa, protegidos por aceite y envueltos en resistente película plástica

- Full of grease, protected by oil and wrapped in resistant plastic film

▷ P= tapón inserción bolas / filling plug

▶ G= n.4 engrasadores M8X1 / n.4 greasers M8X1

Mf
Momento de inclinación equivalente [KNm]
Equivalent Tilting moment [KNm]



DIAGRAMA DE CARGA ESTÁTICA PARA ESFUERZOS DE COMPRESIÓN

STATIC LOAD CHARTS VALID FOR COMPRESSIVE LOADS

Fa
Carga axial equivalente [KN]
Equivalent axial load [KN]

Leer las instrucciones técnicas - parte 2 - para la utilización correcta del gráfico

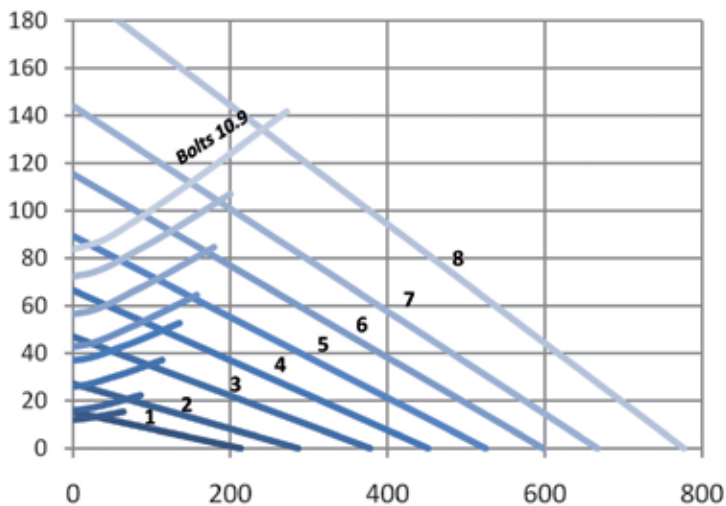
Please read technical instruction part 2 for correct use of load graph.

ZBL.30 S

SERIE CON BRIDAS ESTÁNDAR

FLANGED STANDARD SERIES

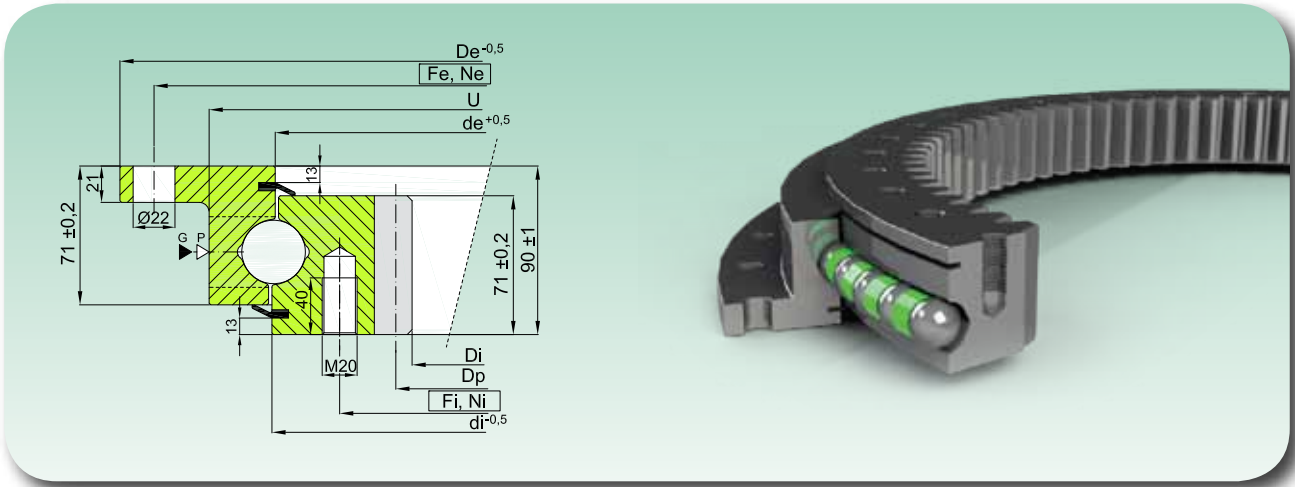

Código Code	Curva Curve	Dimensiones Dimensions					Orificios de fijación Fixing Holes				Dentado Gear data				Peso Weight [kg]	
		De [mm]	U [mm]	de [mm]	di [mm]	Di [mm]	Fe [mm]	Ne [-]	Fi [mm]	Ni [-]	m [mm]	Z [-]	Dp [mm]	fz norm [kN]		fz max [kN]
ZBL.30.0955.200 -1SPTN	1	1100	1017	953,5	956,5	812	1060	30	894	30	10	83	830	50,29	100,58	159
ZBL.30.0955.200 -1SPTN	2	1200	1117	1053,5	1056,5	912	1160	30	994	30	10	93	930	50,29	100,58	176
ZBL.30.1155.200 -1SPTN	3	1300	1217	1153,5	1156,5	1012	1260	36	1094	36	10	103	1030	50,29	100,58	192
ZBL.30.1255.200 -1SPTN	4	1400	1317	1253,5	1256,5	1112	1360	42	1194	42	10	113	1130	50,29	100,58	208
ZBL.30.1355.200 -1SPTN	5	1500	1417	1353,5	1356,5	1212	1460	42	1294	42	10	123	1230	50,29	100,58	226
ZBL.30.1455.200 -1SPTN	6	1600	1517	1453,5	1456,5	1312	1560	48	1394	48	10	133	1330	50,29	100,58	243

- Material: C45Q+T - Material C45 Q+T
 - Juego axial máx. 0,40 mm - Juego radial máx. 0,30 mm - Axial clearance max. 0,40 mm - Radial clearance max. 0,30 mm
 - Llenos de grasa, protegidos por aceite y envueltos en resistente película plástica - Full of grease, protected by oil and wrapped in resistant plastic film
 ▷ P=tapón inserción bolas / filling plug ▶ G= n.6 engrasadores M8X1 / n.6 greasers M8X1

Mf
Momento de inclinación equivalente [KNm]
Equivalent Tilting moment [KNm]

Leer las instrucciones técnicas - parte 2 - para la utilización correcta del gráfico

Please read technical instruction part 2 for correct use of load graph.



DIAGRAMA DE CARGA ESTÁTICA PARA ESFUERZOS DE COMPRESIÓN

STATIC LOAD CHARTS VALID FOR COMPRESSIVE LOADS

Fa

Carga axial equivalente [KN]
Equivalent axial load [KN]

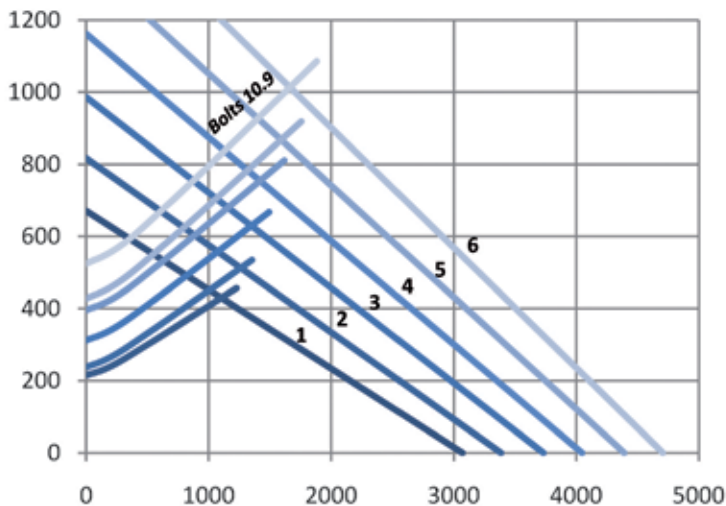
ZBL.30 P

SERIE CON BRIDAS, DE PRECISIÓN

FLANGED PRECISION SERIES

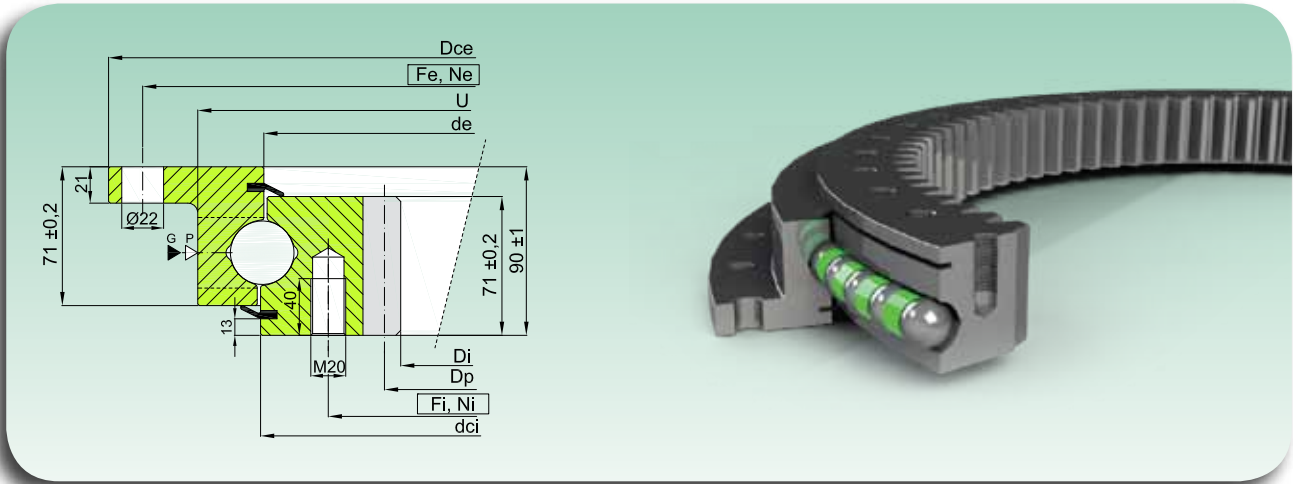

Código Code	Curva Curve	Dimensiones Dimensions				Orificios de fijación Fixing Holes				Dentado Gear data				Juego ax. y radial Axial and Radial Clearance	Peso Weight		
		Dce [mm]	U [mm]	de [mm]	dci [mm]	Di [mm]	Fe [mm]	Ne [-]	Fi [mm]	Ni [-]	m [mm]	Z [-]	Dp [mm]			fz norm [kN]	fz max [kN]
ZBL.30.0955.201-2SPTN	1	1098 -0,17	1017	953,5	955 -0,14	812	1060	30	894	30	10	83	830	50,29	100,58	0 ÷ 0,06	159
ZBL.30.1055.201-2SPTN	2	1198 -0,17	1117	1053,5	1055 -0,17	912	1160	30	994	30	10	93	930	50,29	100,58	0 ÷ 0,06	176
ZBL.30.1155.201-2SPTN	3	1298 -0,20	1217	1153,5	1155 -0,17	1012	1260	36	1094	36	10	103	1030	50,29	100,58	0 ÷ 0,06	192
ZBL.30.1255.201-2SPTN	4	1398 -0,20	1317	1253,5	1255 -0,20	1112	1360	42	1194	42	10	113	1130	50,29	100,58	0 ÷ 0,07	208
ZBL.30.1355.201-2SPTN	5	1498 -0,20	1417	1353,5	1355 -0,20	1212	1460	42	1294	42	10	123	1230	50,29	100,58	0 ÷ 0,07	226
ZBL.30.1455.201-2SPTN	6	1598 -0,20	1517	1453,5	1455 -0,20	1312	1560	48	1394	48	10	133	1330	50,29	100,58	0 ÷ 0,07	243

- Material: C45Q+T

- Material C45 Q+T

- Llenos de grasa, protegidos por aceite y envueltos en resistente película plástica

- Full of grease, protected by oil and wrapped in resistant plastic film

▷ P=tapón inserción bolas / filling plug

▶ G= n.6 engrasadores M8X1 / n.6 greasers M8X1

Mf
Momento de inclinación equivalente [KNm]
Equivalent Tilting moment [KNm]



DIAGRAMA DE CARGA ESTÁTICA PARA ESFUERZOS DE COMPRESIÓN

STATIC LOAD CHARTS VALID FOR COMPRESSIVE LOADS

Fa

Carga axial equivalente [KN]
Equivalent axial load [KN]

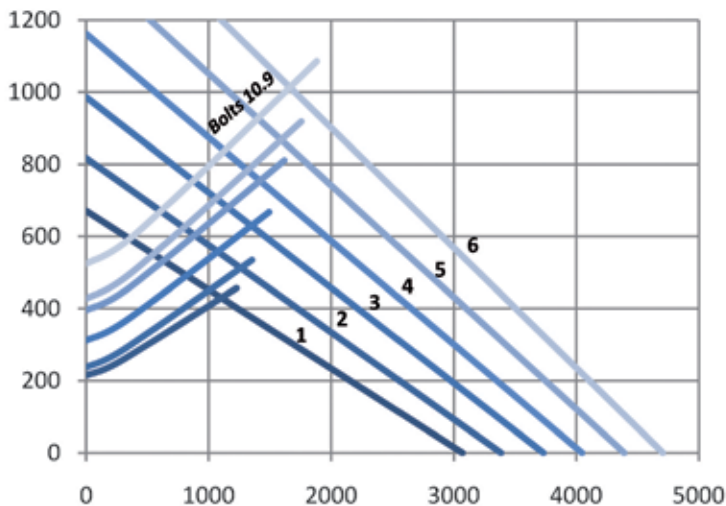
Leer las instrucciones técnicas - parte 2 - para la utilización correcta del gráfico

Please read technical instruction part 2 for correct use of load graph.





Coronas giratorias con bridas de una hilera de bolas, sin dentado

One row ball flanged bearing, untoothed

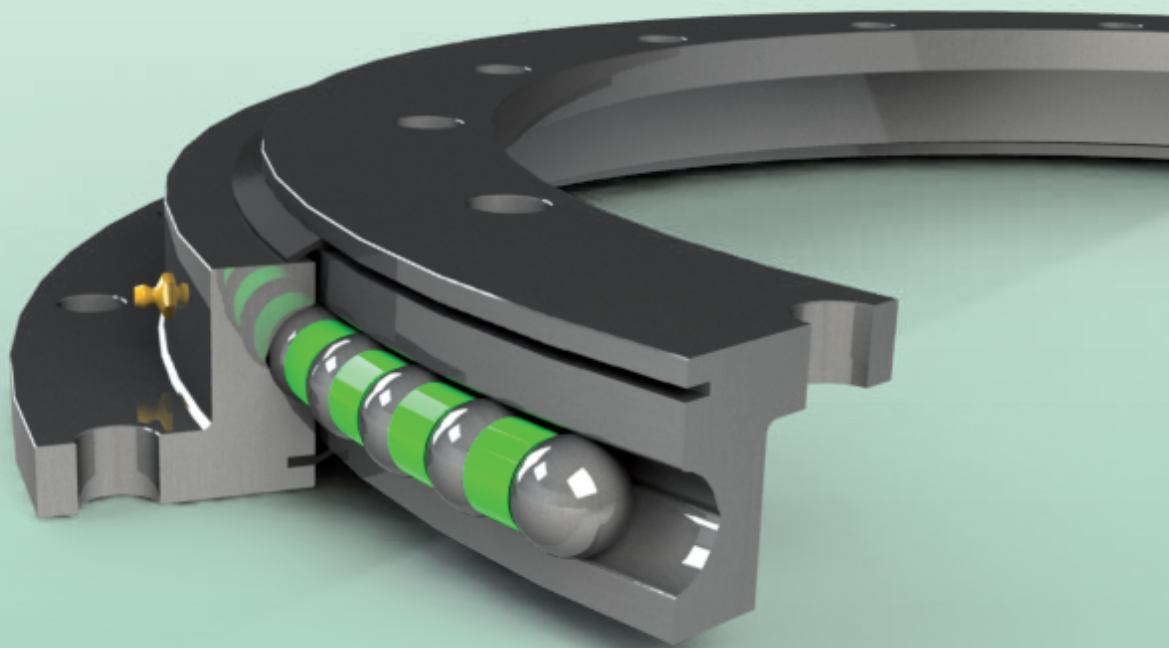

NBL SERIES

NBL.20 S

SERIE CON BRIDAS ESTÁNDAR

FLANGED STANDARD SERIES

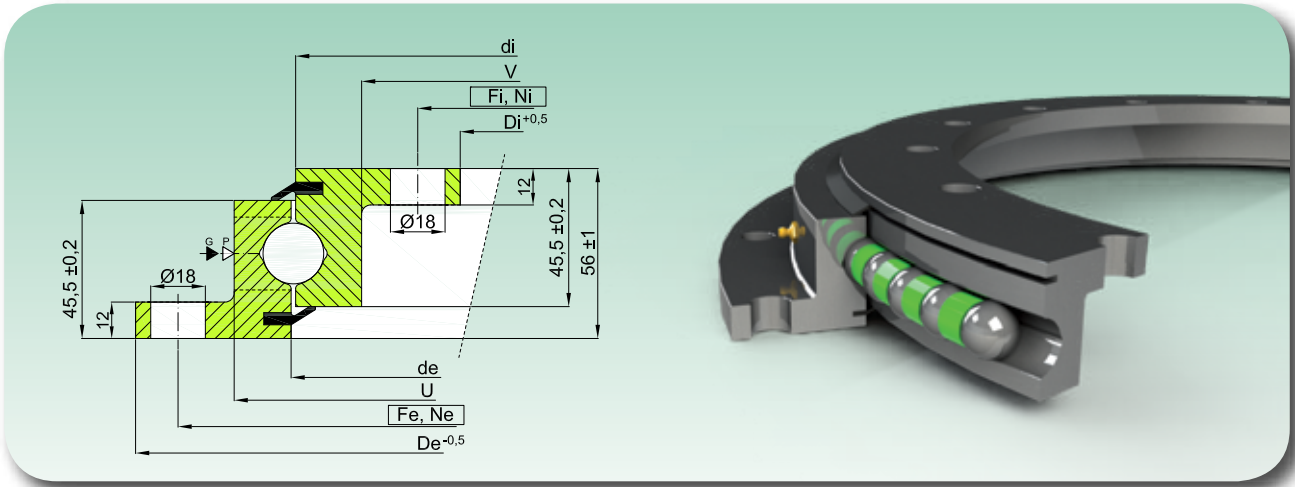

Código Code	Curva Curve	Dimensiones Dimensions						Orificios de fijación Fixing Holes				Peso Weight [kg]
		De [mm]	U [mm]	de [mm]	di [mm]	V [mm]	Di [mm]	Fe [mm]	Ne [-]	Fi [mm]	Ni [-]	
NBL.20.0314.200-1PPN	1	418	353	315,5	312,5	269	204	390	8	232	12	19
NBL.20.0414.200-1PPN	2	518	453	415,5	412,5	369	304	490	8	332	12	25
NBL.20.0544.200-1PPN	3	648	583	545,5	542,5	499	434	620	10	462	14	33
NBL.20.0644.200-1PPN	4	748	683	645,5	642,5	599	534	720	12	562	16	40
NBL.20.0744.200-1PPN	5	848	783	745,5	742,5	699	634	820	12	662	16	46
NBL.20.0844.200-1PPN	6	948	883	845,5	842,5	799	734	920	14	762	18	52
NBL.20.0944.200-1PPN	7	1048	983	945,5	942,5	899	834	1020	16	862	20	58
NBL.20.1094.200-1PPN	8	1198	1133	1095,5	1092,5	1049	984	1170	16	1012	20	68

- Material: C45Q+T

- Juego axial máx. 0,35 mm - Juego radial máx. 0,25 mm

- Llenos de grasa, protegidos por aceite y envueltos en resistente película plástica

▷ P= tapón inserción bolas / filling plug

▷ G= n.4 engrasadores M8X1 / n.4 greasers M8X1

- Material C45 Q+T

- Axial clearance max. 0,35 mm - Radial clearance max. 0,25 mm

- Full of grease, protected by oil and wrapped in resistant plastic film

Mf

Momento de inclinación equivalente [KNm]
Equivalent Tilting moment [KNm]

Leer las instrucciones técnicas - parte 2 - para la utilización correcta del gráfico

Please read technical instruction part 2 for correct use of load graph.



DIAGRAMA DE CARGA ESTÁTICA PARA ESFUERZOS DE COMPRESIÓN

STATIC LOAD CHARTS VALID FOR COMPRESSIVE LOADS

Fa

Carga axial equivalente [KN]
Equivalent axial load [KN]

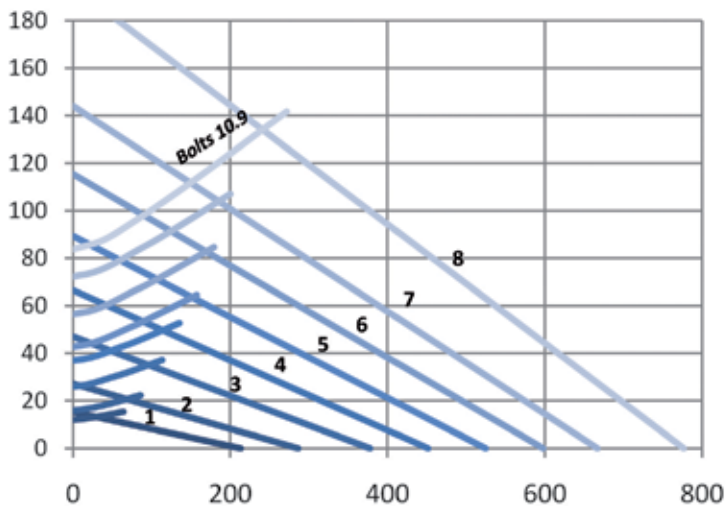
NBL.20 P

SERIE CON BRIDAS, DE PRECISIÓN

FLANGED PRECISION SERIES

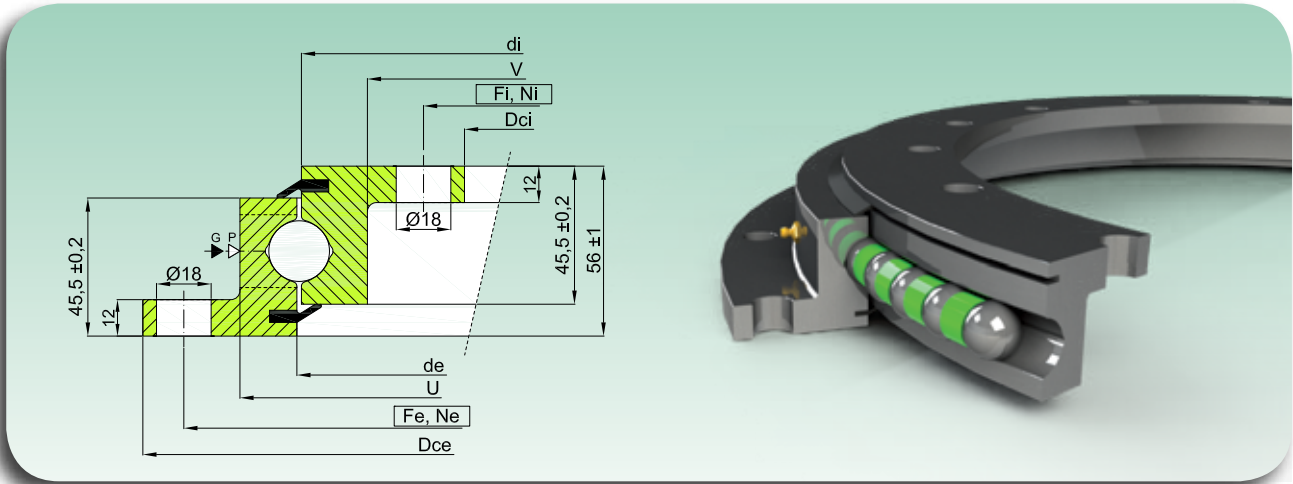

Código Code	Curva Curve	Dimensiones Dimensions						Orificios de fijación Fixing Holes				Juego ax. y radial Axial and Radial Clearance	Peso Weight
		Dce	U	de	di	V	Dci	Fe	Ne	Fi	Ni		
		[mm]	[mm]	[mm]	[mm]	[mm]	[mm]	[mm]	[-]	[mm]	[-]	[mm]	[kg]
NBL.20.0314.201-2PPN	1	417 -0,10	353	315,5	312,5	269	205 +0,07	390	8	232	12	0 ÷ 0,03	19
NBL.20.0414.201-2PPN	2	517 -0,11	453	415,5	412,5	369	305 +0,09	490	8	332	12	0 ÷ 0,03	25
NBL.20.0544.201-2PPN	3	647 -0,13	583	545,5	542,5	499	435 +0,10	620	10	462	14	0 ÷ 0,03	33
NBL.20.0644.201-2PPN	4	747 -0,13	683	645,5	642,5	599	535 +0,11	720	12	562	16	0 ÷ 0,04	40
NBL.20.0744.201-2PPN	5	847 -0,14	783	745,5	742,5	699	635 +0,13	820	12	662	16	0 ÷ 0,04	46
NBL.20.0844.201-2PPN	6	947 -0,14	883	845,5	842,5	799	735 +0,13	920	14	762	18	0 ÷ 0,05	52
NBL.20.0944.201-2PPN	7	1047 -0,17	983	945,5	942,5	899	835 +0,14	1020	16	862	20	0 ÷ 0,05	58
NBL.20.1094.201-2PPN	8	1197 -0,17	1133	1095,5	1092,5	1049	985 +0,17	1170	16	1012	20	0 ÷ 0,06	68

- Material: C45Q+T

- Material C45 Q+T

- Llenos de grasa, protegidos por aceite y envueltos en resistente película plástica

- Full of grease, protected by oil and wrapped in resistant plastic film

▷ P=tapón inserción bolas / filling plug

▶ G= n.4 engrasadores M8X1 / n.4 greasers M8X1

Mf
Momento de inclinación equivalente [KNm]
Equivalent Tilting moment [KNm]



DIAGRAMA DE CARGA ESTÁTICA PARA ESFUERZOS DE COMPRESIÓN

STATIC LOAD CHARTS VALID FOR COMPRESSIVE LOADS

Fa

Carga axial equivalente [KN]
Equivalent axial load [KN]

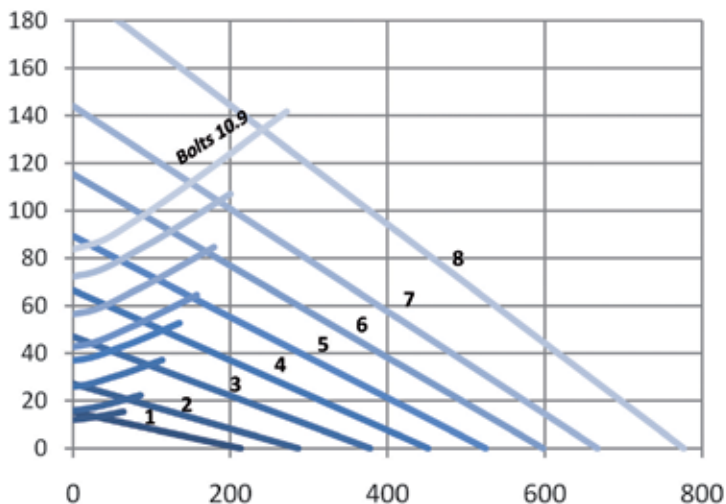
Leer las instrucciones técnicas - parte 2 - para la utilización correcta del gráfico

Please read technical instruction part 2 for correct use of load graph.

NBL.30 S

SERIE CON BRIDAS ESTÁNDAR

FLANGED STANDARD SERIES

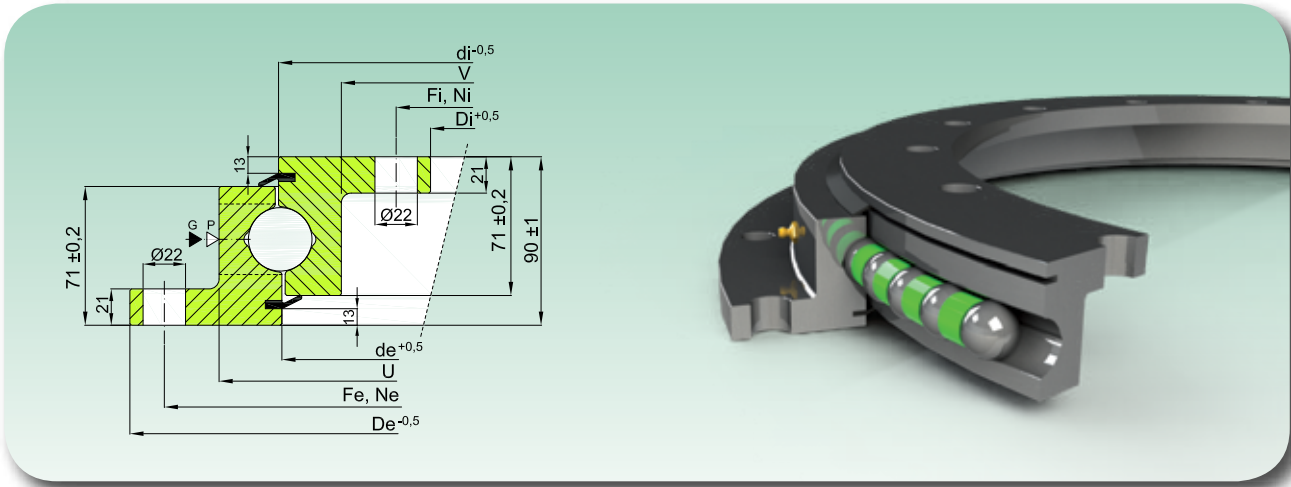

Código Code	Curva Curve	Dimensiones Dimensions						Orificios de fijación Fixing Holes				Peso Weight [kg]
		De [mm]	U [mm]	de [mm]	di [mm]	V [mm]	Di [mm]	Fe [mm]	Ne [-]	Fi [mm]	Ni [-]	
NBL.30.0955.200-1PPN	1	1100	1017	953,5	956,5	893	805	1060	30	845	30	131
NBL.30.0955.200-1PPN	2	1200	1117	1053,5	1056,5	993	905	1160	30	945	30	145
NBL.30.1155.200-1PPN	3	1300	1217	1153,5	1156,5	1093	1005	1260	36	1045	36	159
NBL.30.1255.200-1PPN	4	1400	1317	1253,5	1256,5	1193	1105	1360	42	1145	42	172
NBL.30.1355.200-1PPN	5	1500	1417	1353,5	1356,5	1293	1205	1460	42	1245	42	186
NBL.30.1455.200-1PPN	6	1600	1517	1453,5	1456,5	1393	1305	1560	48	1345	48	200

- Material: C45Q+T
- Juego axial máx. 0,40 mm - Juego radial máx. 0,30 mm
- Llenos de grasa, protegidos por aceite y envueltos en resistente película plástica
- ▷ P= tapón inserción bolas / filling plug ▶ G= n.6 engrasadores M8X1 / n.6 greasers M8X1
- Material C45 Q+T
- Axial clearance max. 0,40 mm - Radial clearance max. 0,30 mm
- Full of grease, protected by oil and wrapped in resistant plastic film

Mf
Momento de inclinación equivalente [KNm]
Equivalent Tilting moment [KNm]



DIAGRAMA DE CARGA ESTÁTICA PARA ESFUERZOS DE COMPRESIÓN

STATIC LOAD CHARTS VALID FOR COMPRESSIVE LOADS

Fa
Carga axial equivalente [KN]
Equivalent axial load [KN]

Leer las instrucciones técnicas - parte 2 - para la utilización correcta del gráfico

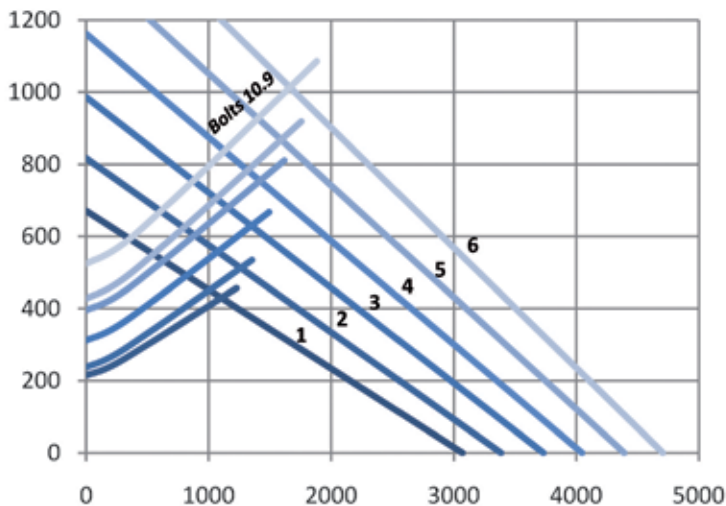
Please read technical instruction part 2 for correct use of load graph.

NBL.30 P

SERIE CON BRIDAS, DE PRECISIÓN

FLANGED PRECISION SERIES

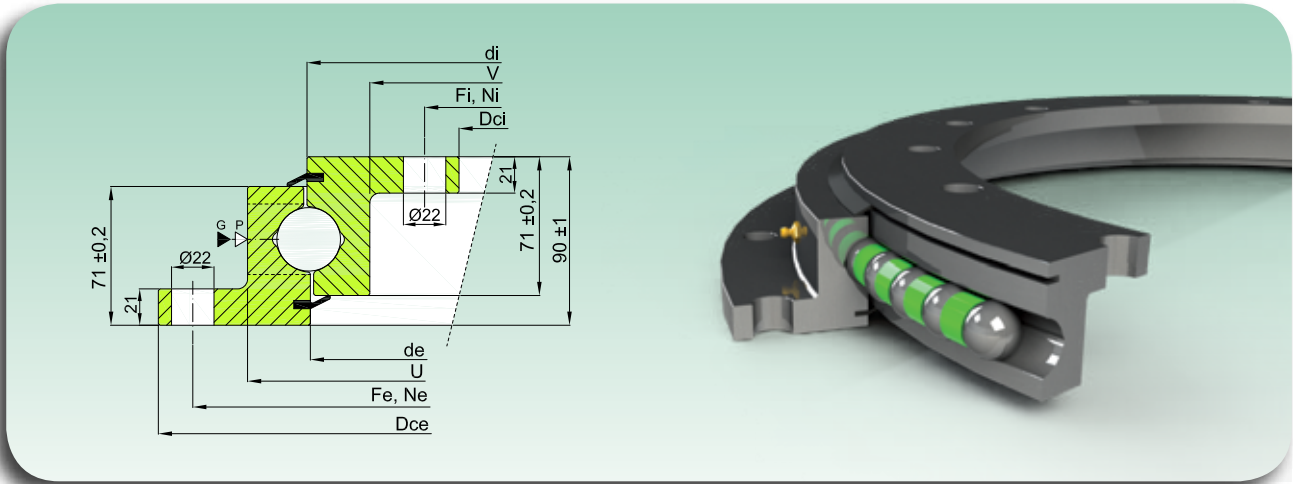

Código Code	Curva Curve	Dimensiones Dimensions						Orificios de fijación Fixing Holes				Juego ax. y radial Axial and Radial Clearance	Peso Weight
		Dce	U	de	di	V	Dci	Fe	Ne	Fi	Ni		
		[mm]	[mm]	[mm]	[mm]	[mm]	[mm]	[mm]	[-]	[mm]	[-]	[mm]	[kg]
NBL.30.0955.201-2PPN	1	1098 -0,17	1017	953,5	956,5	893	807 +0,14	1060	30	845	30	0 ÷ 0,06	131
NBL.30.0955.201-2PPN	2	1198 -0,17	1117	1053,5	1056,5	993	907 +0,14	1160	30	945	30	0 ÷ 0,06	145
NBL.30.1155.201-2PPN	3	1298 -0,20	1217	1153,5	1156,5	1093	1007 +0,17	1260	36	1045	36	0 ÷ 0,06	159
NBL.30.1255.201-2PPN	4	1398 -0,20	1317	1253,5	1256,5	1193	1107 +0,17	1360	42	1145	42	0 ÷ 0,07	172
NBL.30.1355.201-2PPN	5	1498 -0,20	1417	1353,5	1356,5	1293	1207 +0,17	1460	42	1245	42	0 ÷ 0,07	186
NBL.30.1455.201-2PPN	6	1598 -0,20	1517	1453,5	1456,5	1393	1307 +0,20	1560	48	1345	48	0 ÷ 0,07	200

- Material: C45Q+T

- Material C45 Q+T

- Llenos de grasa, protegidos por aceite y envueltos en resistente película plástica

- Full of grease, protected by oil and wrapped in resistant plastic film

▷ P=tapón inserción bolas / filling plug

▶ G= n.6 engrasadores M8X1 / n.6 greasers M8X1

Mf
Momento de inclinación equivalente [KNm]
Equivalent Tilting moment [KNm]



DIAGRAMA DE CARGA ESTÁTICA PARA ESFUERZOS DE COMPRESIÓN

STATIC LOAD CHARTS VALID FOR COMPRESSIVE LOADS

Fa

Carga axial equivalente [KN]
Equivalent axial load [KN]

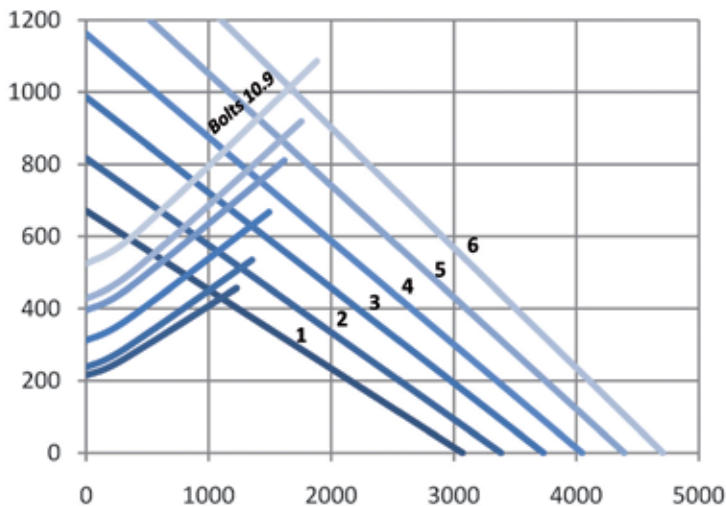
Leer las instrucciones técnicas - parte 2 - para la utilización correcta del gráfico

Please read technical instruction part 2 for correct use of load graph.





Coronas giratorias de una hilera de bolas, dentado exterior

One row ball bearing, external toothed

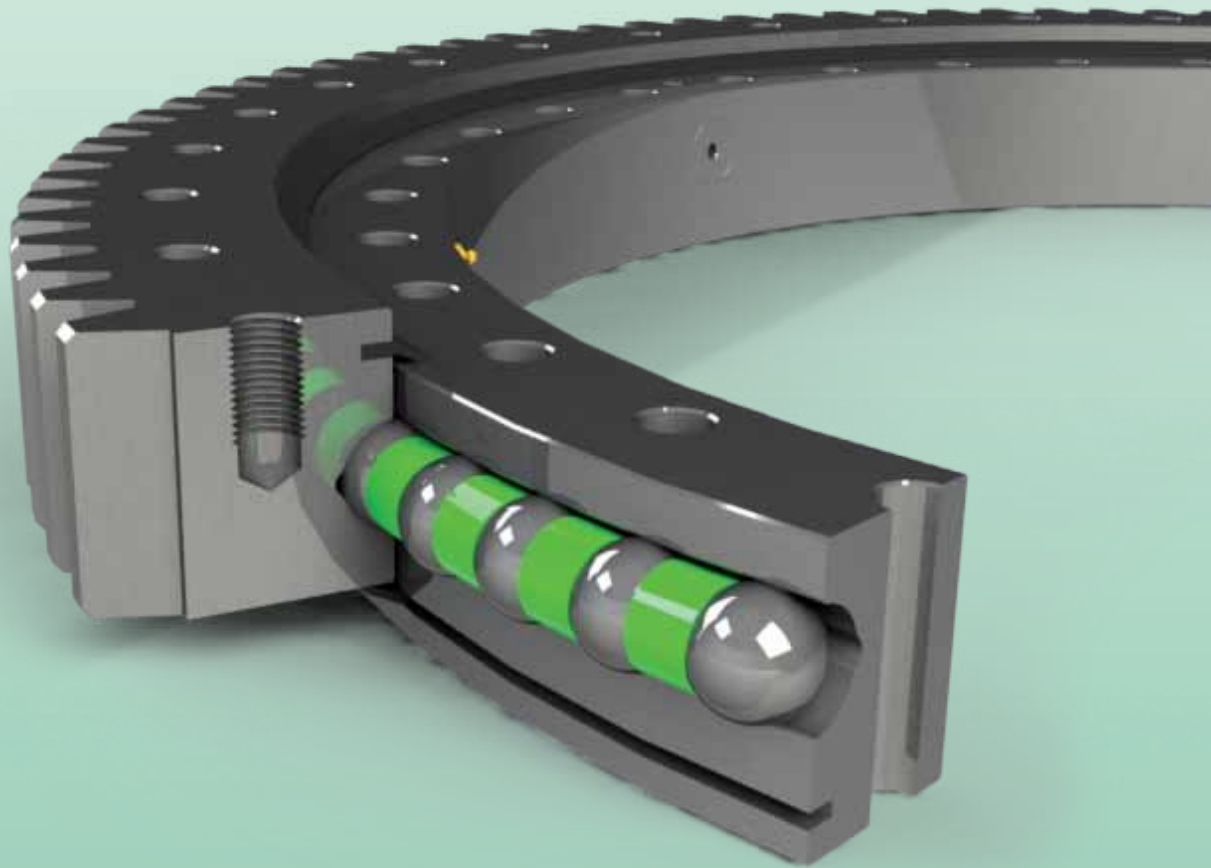

EB1 SERIES

EB1.20 S

SERIE ESTÁNDAR

STANDARD SERIES

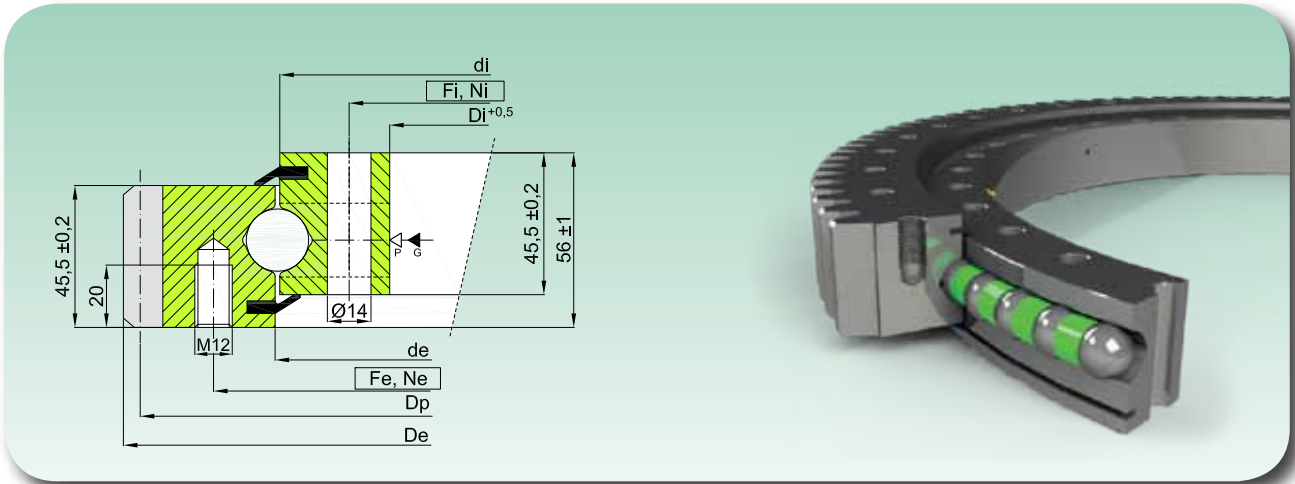

Código Code	Curva Curve	Dimensiones Dimensions				Orificios de fijación Fixing Holes				Dentado Gear data				Peso Weight [kg]	
		De [mm]	de [mm]	di [mm]	Di [mm]	Fe [mm]	Ne [-]	Fi [mm]	Ni [-]	m [mm]	Z [-]	Dp [mm]	fz norm [kN]		fz max [kN]
EBL.20.0314.200-1STPN	1	404	315,5	312,5	242	355	20	268	20	5	79	395	14,96	29,92	23
EB1.20.0414.200-1STPN	2	504	415,5	412,5	342	455	20	368	24	5	99	495	14,96	29,92	32
EB1.20.0544.200-1STPN	3	640,8	545,5	542,5	472	585	28	498	32	6	105	630	17,95	35,9	43
EB1.20.0644.200-1STPN	4	742,8	645,5	642,5	572	685	32	598	36	6	122	732	17,95	35,9	52
EB1.20.0744.200-1STPN	5	838,8	745,5	742,5	672	785	36	698	40	6	138	828	17,95	35,9	58
EB1.20.0844.200-1STPN	6	950,4	845,5	842,5	772	885	36	798	40	8	117	936	23,94	47,87	71
EB1.20.0944.200-1STPN	7	1046,4	945,5	942,5	872	985	40	898	44	8	129	1032	23,94	47,87	77
EB1.20.1094.200-1STPN	8	1198,4	1095,5	1092,5	1022	1135	44	1048	48	8	148	1184	23,94	47,87	90

- Material: C45Q+T

- Juego axial máx. 0,35 mm - Juego radial máx. 0,25 mm

- Llenos de grasa, protegidos por aceite y envueltos en resistente película plástica

▷ P= tapón inserción bolas / filling plug

- Material C45 Q+T

- Axial clearance max. 0,35 mm - Radial clearance max. 0,25 mm

- Full of grease, protected by oil and wrapped in resistant plastic film

▶ G= n.4 engrasadores M8X1 / n.4 greasers M8X1

Mf
Momento de inclinación equivalente [KNm]
Equivalent Tilting moment [KNm]



DIAGRAMA DE CARGA ESTÁTICA PARA ESFUERZOS DE COMPRESIÓN

STATIC LOAD CHARTS VALID FOR COMPRESSIVE LOADS

Fa

Carga axial equivalente [KN]
Equivalent axial load [KN]

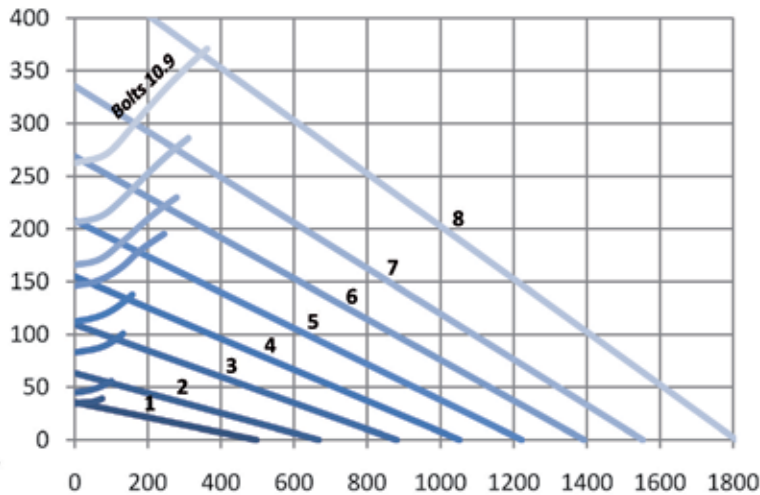
Leer las instrucciones técnicas - parte 2 - para la utilización correcta del gráfico

Please read technical instruction part 2 for correct use of load graph.

EB1.20 P

SERIE DE PRECISIÓN

PRECISION SERIES

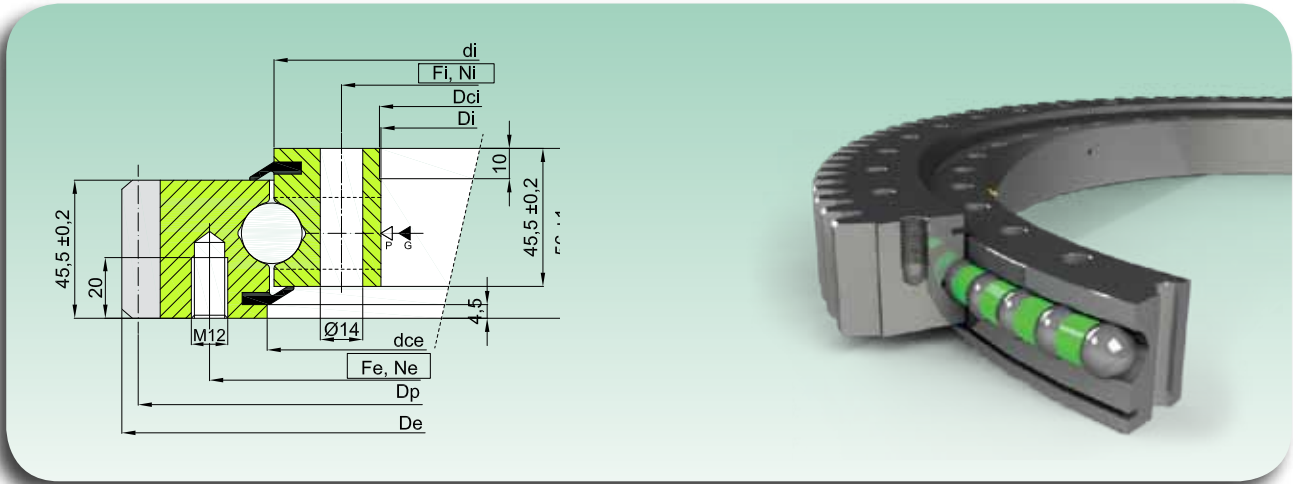

Código Code	Curva Curve	Dimensiones Dimensions					Orificios de fijación Fixing Holes				Dentado Gear data			Juego ax. y radial Axial and Radial Clearance	Peso Weight		
		De [mm]	dce [mm]	di [mm]	Dci [mm]	Di [mm]	Fe [mm]	Ne [-]	Fi [mm]	Ni [-]	m [mm]	Z [-]	Dp [mm]			fz norm [kN]	fz max [kN]
EB1.20.0314.201-2STPN	1	404	317 +0,09	312,5	243,5 +0,07	242	355	20	268	20	5	79	395	14,96	29,92	0 ÷ 0,03	23
EB1.20.0414.201-2STPN	2	504	417 +0,10	412,5	343,5 +0,09	342	455	20	368	24	5	99	495	14,96	29,92	0 ÷ 0,03	32
EB1.20.0544.201-2STPN	3	640,8	547 +0,11	542,5	473,5 +0,10	472	585	28	498	32	6	105	630	17,95	35,9	0 ÷ 0,03	43
EB1.20.0644.201-2STPN	4	742,8	647 +0,13	642,5	573,5 +0,11	572	685	32	598	36	6	122	732	17,95	35,9	0 ÷ 0,04	52
EB1.20.0744.201-2STPN	5	838,8	747 +0,13	742,5	673,5 +0,13	672	785	36	698	40	6	138	828	17,95	35,9	0 ÷ 0,04	58
EB1.20.0844.201-2STPN	6	950,4	847 +0,14	842,5	773,5 +0,13	772	885	36	798	40	8	117	936	23,94	47,87	0 ÷ 0,05	71
EB1.20.0944.201-2STPN	7	1046,4	947 +0,14	942,5	873,5 +0,14	872	985	40	898	44	8	129	1032	23,94	47,87	0 ÷ 0,05	77
EB1.20.1094.201-2STPN	8	1198,4	1097 +0,17	1092,5	1023,5 +0,17	1022	1135	44	1048	48	8	148	1184	23,94	47,87	0 ÷ 0,06	90

- Material: C45Q+T

- Material C45 Q+T

- Llenos de grasa, protegidos por aceite y envueltos en resistente película plástica

- Full of grease, protected by oil and wrapped in resistant plastic film

▷ P=tapón inserción bolas / filling plug

▶ G= n.4 engrasadores M8X1 / n.4 greasers M8X1

Mf
Momento de inclinación equivalente [KNm]
Equivalent Tilting moment [KNm]



DIAGRAMA DE CARGA ESTÁTICA PARA ESFUERZOS DE COMPRESIÓN

STATIC LOAD CHARTS VALID FOR COMPRESSIVE LOADS

Fa

Carga axial equivalente [KN]
Equivalent axial load [KN]

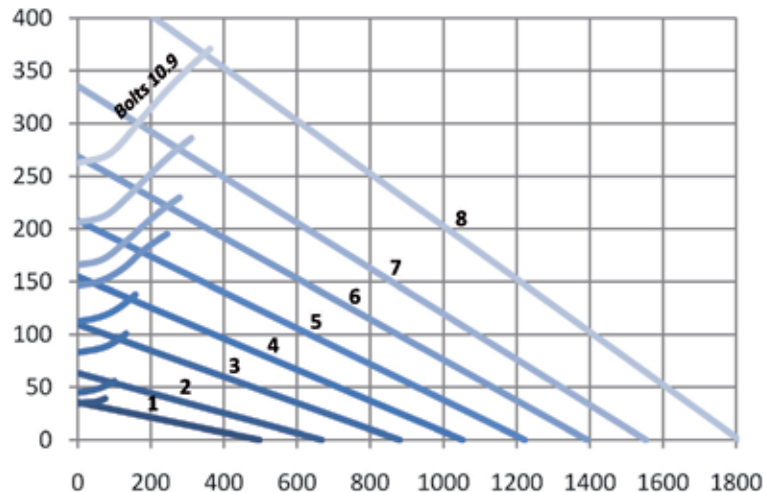
Leer las instrucciones técnicas - parte 2 - para la utilización correcta del gráfico

Please read technical instruction part 2 for correct use of load graph.

EB1.25 S

SERIE ESTÁNDAR

STANDARD SERIES

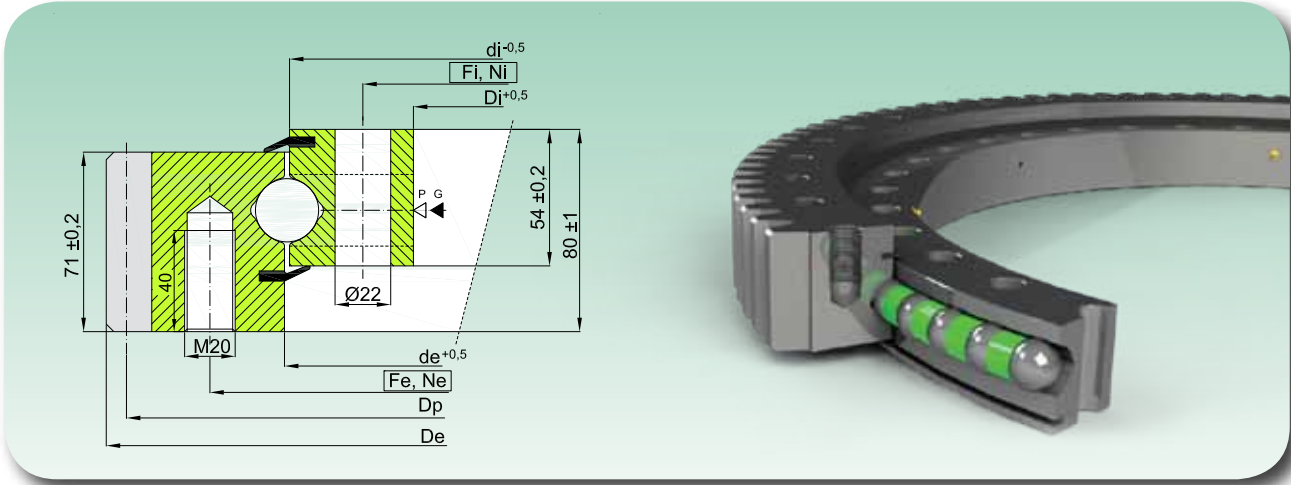

Código Code	Curva Curve	Dimensiones Dimensions				Orificios de fijación Fixing Holes				Dentado Gear data				Peso Weight [kg]	
		De [mm]	de [mm]	di [mm]	Di [mm]	Fe [mm]	Ne [-]	Fi [mm]	Ni [-]	m [mm]	Z [-]	Dp [mm]	fz norm [kN]		fz max [kN]
EBL.20.0314.200-1STPN	1	590,4	454	456	355	516	18	395	18	8	72	576	38,62	77,25	74
EB1.25.0555.200-1STPN	2	694,4	554	556	455	616	20	495	20	8	85	680	38,62	77,25	93
EB1.25.0655.200-1STPN	3	798,4	654	656	555	716	24	595	24	8	98	784	38,62	77,25	111
EB1.25.0755.200-1STPN	4	898	754	756	655	816	24	695	24	9	98	882	43,45	86,9	125
EB1.25.0855.200-1STPN	5	997	854	856	755	916	28	795	28	9	109	981	43,45	86,9	145
EB1.25.0955.200-1STPN	6	1096	954	956	855	1016	30	895	30	9	120	1080	43,45	86,9	155
EB1.25.1055.200-1STPN	7	1198	1054	1056	955	1116	30	995	30	10	118	1180	48,28	96,56	171
EB1.25.1155.200-1STPN	8	1298	1154	1156	1055	1216	36	1095	36	10	128	1280	48,28	96,56	186
EB1.25.1255.200-1STPN	9	1398	1254	1256	1155	1316	42	1195	42	10	138	1380	48,28	96,56	201
EB1.25.1355.200-1STPN	10	1498	1354	1356	1255	1416	42	1295	42	10	148	1480	48,28	96,56	218
EB1.25.1455.200-1STPN	11	1598	1454	1456	1355	1516	48	1395	48	10	158	1580	48,28	96,56	233

- Material: C45Q+T

- Juego axial máx. 0,40 mm - Juego radial máx. 0,30 mm

- Llenos de grasa, protegidos por aceite y envueltos en resistente película plástica

▷ P= tapón inserción bolas / filling plug

- Material C45 Q+T

- Axial clearance max. 0,40 mm - Radial clearance max. 0,30 mm

- Full of grease, protected by oil and wrapped in resistant plastic film

▶ G= n.4/6 engrasadores M10X1 / n.4/6greasers M10X1.

Mf
Momento de inclinación equivalente [KNm]
Equivalent Tilting moment [KNm]

Leer las instrucciones técnicas - parte 2 - para la utilización correcta del gráfico

Please read technical instruction part 2 for correct use of load graph.



DIAGRAMA DE CARGA ESTÁTICA PARA ESFUERZOS DE COMPRESIÓN

STATIC LOAD CHARTS VALID FOR COMPRESSIVE LOADS

Fa

Carga axial equivalente [KN]
Equivalent axial load [KN]

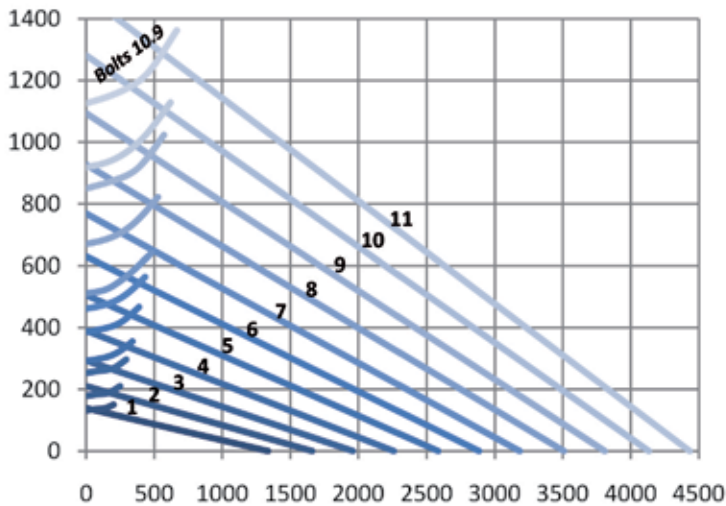
EB1.25 P

SERIE DE PRECISIÓN

PRECISION SERIES

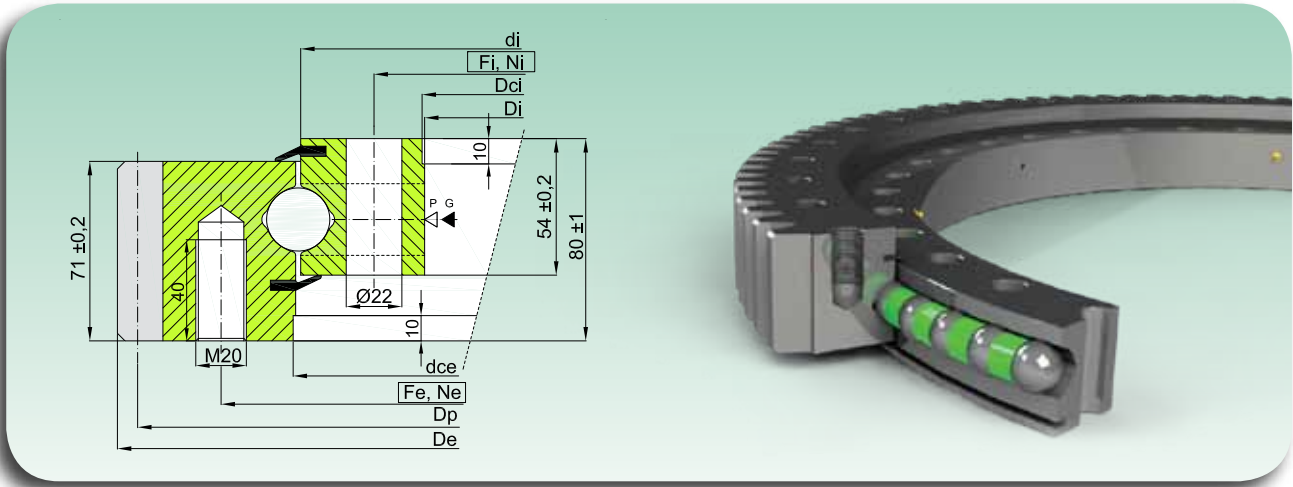

Código Code	Curva Curve	Dimensiones Dimensions					Orificios de fijación Fixing Holes				Dentado Gear data			Juego ax. y radial Axial and Radial Clearance	Peso Weight		
		De [mm]	dce [mm]	di [mm]	Dci [mm]	Di [mm]	Fe [mm]	Ne [-]	Fi [mm]	Ni [-]	m [mm]	Z [-]	Dp [mm]			fz norm [kN]	fz max [kN]
EB1.25.0455.201-2STPN	1	590,4	455 +0,10	456	357 +0,09	355	516	18	395	18	8	72	576	38,62	77,25	0 ÷ 0,03	74
EB1.25.0555.201-2STPN	2	694,4	555 +0,11	556	457 +0,10	455	616	20	495	20	8	85	680	38,62	77,25	0 ÷ 0,03	93
EB1.25.0655.201-2STPN	3	798,4	655 +0,13	656	557 +0,11	555	716	24	595	24	8	98	784	38,62	77,25	0 ÷ 0,03	111
EB1.25.0755.201-2STPN	4	898	755 +0,14	756	657 +0,13	655	816	24	695	24	9	98	882	43,45	86,9	0 ÷ 0,04	125
EB1.25.0855.201-2STPN	5	997	855 +0,14	856	757 +0,14	755	916	28	795	28	9	109	981	43,45	86,9	0 ÷ 0,04	145
EB1.25.0955.201-2STPN	6	1096	955 +0,14	956	857 +0,14	855	1016	30	895	30	9	120	1080	43,45	86,9	0 ÷ 0,05	155
EB1.25.1055.201-2STPN	7	1198	1055 +0,17	1056	957 +0,14	955	1116	30	995	30	10	118	1180	48,28	96,56	0 ÷ 0,05	171
EB1.25.1155.201-2STPN	8	1298	1155 +0,17	1156	1057 +0,17	1055	1216	36	1095	36	10	128	1280	48,28	96,56	0 ÷ 0,06	186
EB1.25.1255.201-2STPN	9	1398	1255 +0,17	1256	1157 +0,17	1155	1316	42	1195	42	10	138	1380	48,28	96,56	0 ÷ 0,07	201
EB1.25.1355.201-2STPN	10	1498	1355 +0,20	1356	1257 +0,17	1255	1416	42	1295	42	10	148	1480	48,28	96,56	0 ÷ 0,07	218
EB1.25.1455.201-2STPN	11	1598	1455 +0,20	1456	1357 +0,20	1355	1516	48	1395	48	10	158	1580	48,28	96,56	0 ÷ 0,07	233

- Material: C45Q+T

- Material C45 Q+T

- Llenos de grasa, protegidos por aceite y envueltos en resistente película plástica

- Full of grease, protected by oil and wrapped in resistant plastic film

▷ P=tapón inserción bolas / filling plug

▶ G= n.4/6 engrasadores M10X1 / n.4/6greasers M10X1

Mf
Momento de inclinación equivalente [KNm]
Equivalent Tilting moment [KNm]

Leer las instrucciones técnicas - parte 2 - para la utilización correcta del gráfico

Please read technical instruction part 2 for correct use of load graph.



DIAGRAMA DE CARGA ESTÁTICA PARA ESFUERZOS DE COMPRESIÓN

STATIC LOAD CHARTS VALID FOR COMPRESSIVE LOADS

Fa

Carga axial equivalente [KN]
Equivalent axial load [KN]

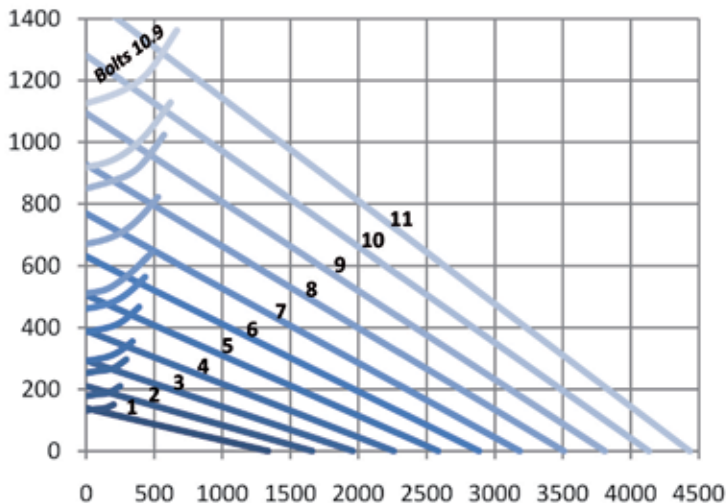
EB1.25 R

SERIE ESTÁNDAR

STANDARD SERIES

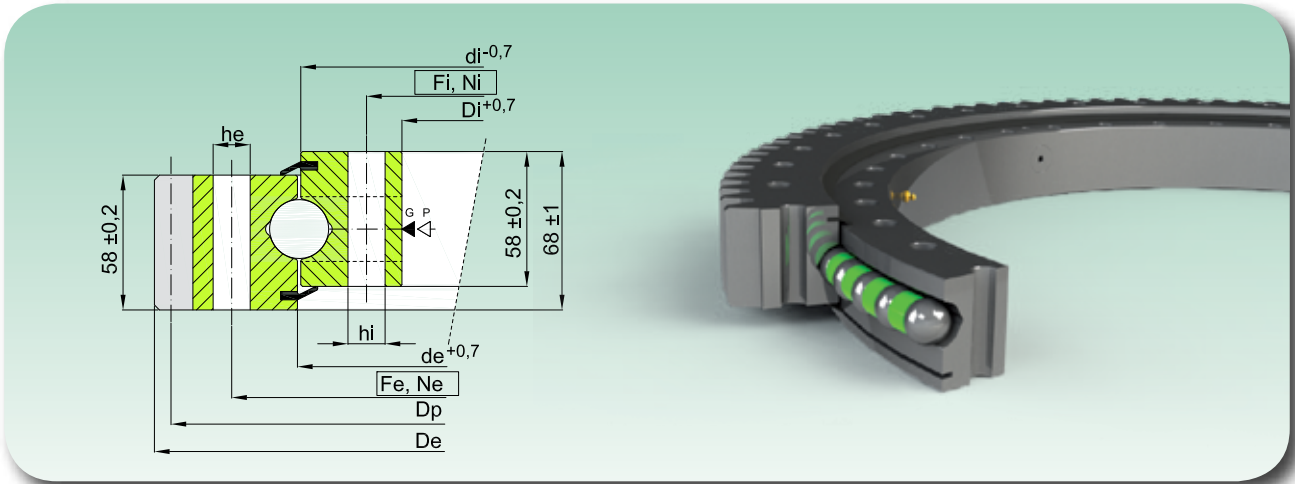

Código Code	Curva Curve	Dimensiones Dimensions				Orificios de fijación Fixing Holes						Dentado Gear data			Peso Weight [kg]		
		De [mm]	de [mm]	di [mm]	Di [mm]	Fe [mm]	Ne [-]	he [mm]	Fi [mm]	Ni [-]	hi [mm]	m [mm]	Z [-]	Dp [mm]		fz norm [kN]	fz max [kN]
EB1.25.1204.400-1SPPN	1	1338	1206	1202	1119	1257	45	16	1151	45	16	10	131	1310	46,4	92,8	135
EB1.25.1314.400-1SPPN	2	1448	1316	1312	1229	1367	50	16	1261	50	16	10	142	1420	46,4	92,8	147
EB1.25.1424.400-1SPPN	3	1558	1426	1422	1339	1477	54	16	1371	54	16	10	153	1530	46,4	92,8	159
EB1.25.1534.400-1SPPN	4	1668	1536	1532	1449	1587	60	16	1481	60	16	10	164	1640	46,4	92,8	171
EB1.25.1644.400-1SPPN	5	1791	1646	1642	1536	1708	54	22	1580	54	22	10	176	1760	46,4	92,8	211
EB1.25.1754.400-1SPPN	6	1901	1756	1752	1646	1818	60	22	1690	60	22	10	187	1870	46,4	92,8	225
EB1.25.1904.400-1SPPN	7	2073	1906	1902	1796	1968	64	22	1840	64	22	14	145	2030	64,96	129,92	270

- Material: 42CrMo4 Q+T

- Juego axial máx. 0,40 mm - Juego radial máx. 0,30 mm

- Llenos de grasa, protegidos por aceite y envueltos en resistente película plástica

▷ P= tapón inserción bolas / filling plug

▶ G= n.6 engrasadores M8X1 / n.6 greasers M8X1.

- Material 42CrMo4 Q+T

- Axial clearance max. 0,40 mm - Radial clearance max. 0,30 mm

- Full of grease, protected by oil and wrapped in resistant plastic film

Mf

Momento de inclinación equivalente [KNm]
Equivalent Tilting moment [KNm]

Leer las instrucciones técnicas - parte 2 - para la utilización correcta del gráfico

Please read technical instruction part 2 for correct use of load graph.



DIAGRAMA DE CARGA ESTÁTICA PARA ESFUERZOS DE COMPRESIÓN

STATIC LOAD CHARTS VALID FOR COMPRESSIVE LOADS

Fa

Carga axial equivalente [KN]
Equivalent axial load [KN]

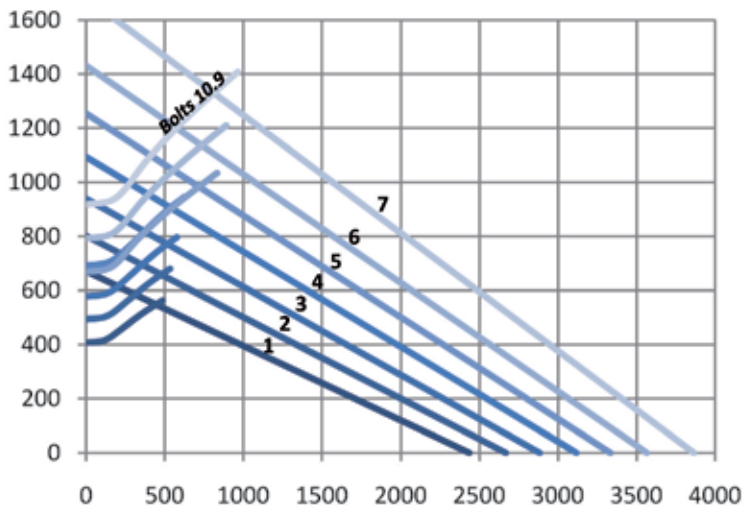
EB1.50 S

SERIE ESTÁNDAR

STANDARD SERIES

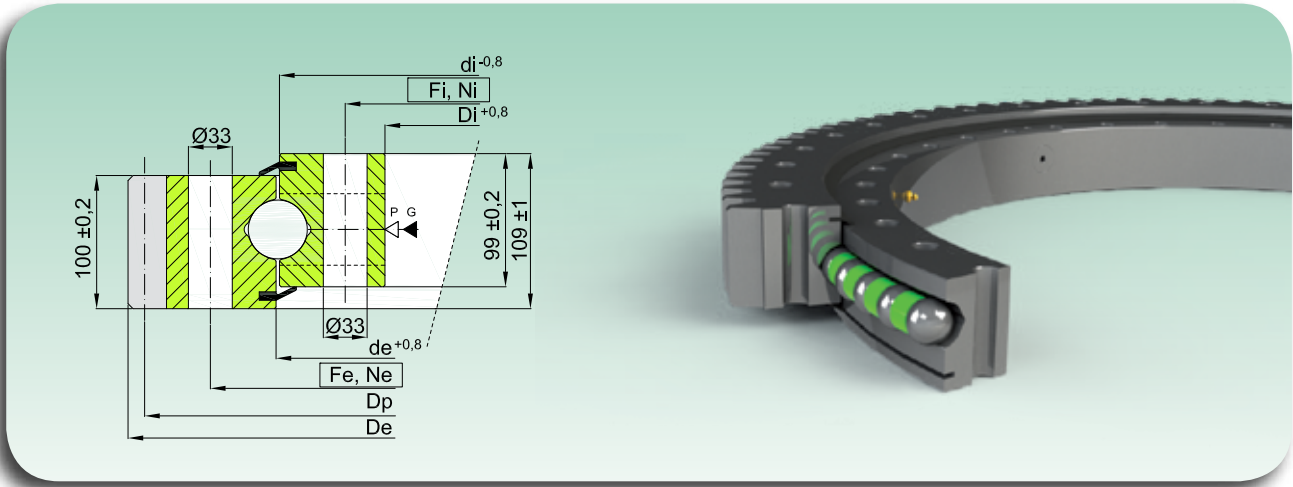

Código Code	Curva Curve	Dimensiones Dimensions				Orificios de fijación Fixing Holes				Dentado Gear data					Peso Weight [kg]	
		De [mm]	de [mm]	di [mm]	Di [mm]	Fe [mm]	Ne [-]	Fi [mm]	Ni [-]	m [mm]	Z [-]	xm [mm]	Dp [mm]	fz norm [kN]		fz max [kN]
EB1.50.1900.400-1SPPN	1	2139,2	1902	1898	1729	2005	36	1795	36	14	150	+0.50	2100	128,5	257	820
EB1.50.2130.400-1SPPN	2	2380,8	2132	2128	1959	2235	48	2025	48	16	146	+0.50	2336	146,8	293,6	931
EB1.50.2355.400-1SPPN	3	2604,8	2357	2353	2184	2460	54	2250	54	16	160	+0.50	2560	146,8	293,6	1024
EB1.50.2645.400-1SPPN	4	2892,8	2647	2643	2474	2750	60	2540	60	16	178	+0.50	2848	146,8	293,6	1142

- Material: C45Q+T

- Material C45 Q+T

- Llenos de grasa, protegidos por aceite y envueltos en resistente película plástica

- Full of grease, protected by oil and wrapped in resistant plastic film

▷ P=tapón inserción bolas / filling plug

▶ G= n.6 engrasadores M8X1 / n.6 greasers M8X1.

Mf
Momento de inclinación equivalente [KNm]
Equivalent Tilting moment [KNm]

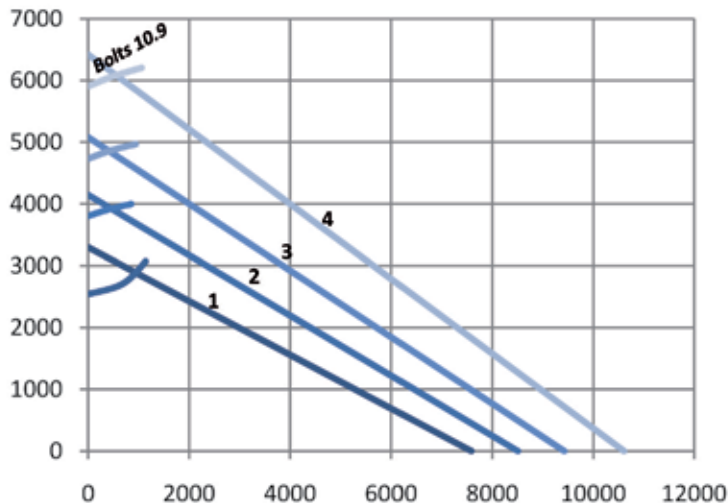

Leer las instrucciones técnicas - parte 2 - para la utilización correcta del gráfico

Please read technical instruction part 2 for correct use of load graph.

DIAGRAMA DE CARGA ESTÁTICA PARA ESFUERZOS DE COMPRESIÓN

STATIC LOAD CHARTS VALID FOR COMPRESSIVE LOADS

Fa

Carga axial equivalente [KN]
Equivalent axial load [KN]

EB1 STOCK

SERIE ESTÁNDAR

STANDARD SERIES

EB1.20.0224.200-1STTN

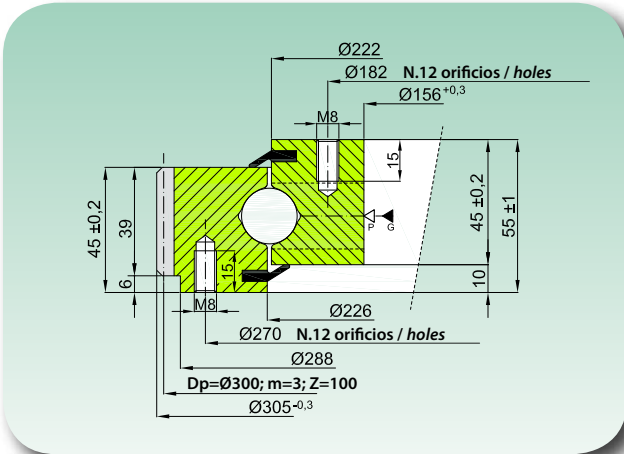

EB1.22.0225.400-1SPPN

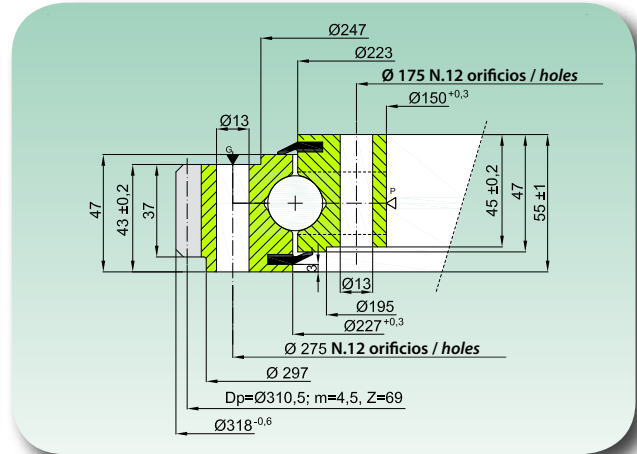

EB1.22.0308.200-1SPPN

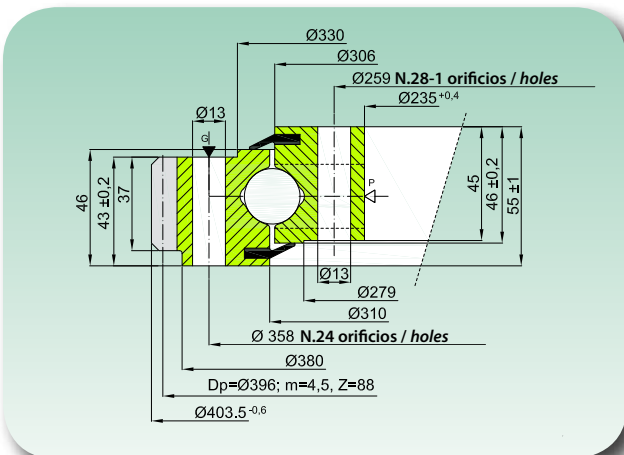

EB1.20.0344.200-1STTN

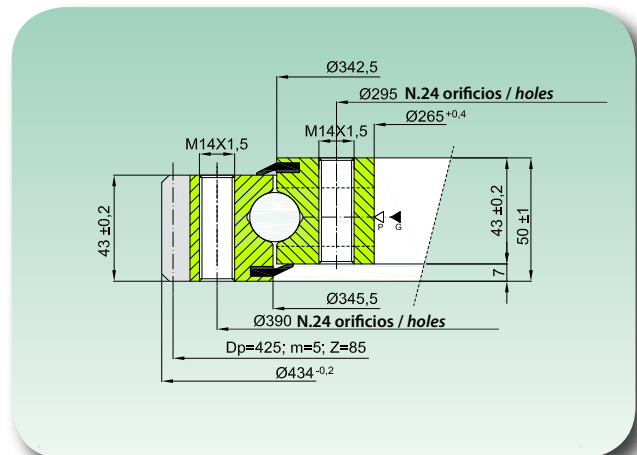

Código Code	Curva Curve	Material Material	Dentado Gear data		Peso Weight [Kg]
			fz nor [kN]	fz max [kN]	
EB1.20.0224.200-1STTN	1	42Cr/C45 Q+T	3,6	7,2	17,5
EB1.22.0225.400-1SPPN	2	42CrMo4 Q+T	11,7	23,4	17
EB1.22.0308.200-1SPPN	3	C45 Q+T	8,4	16,8	23
EB1.20.0344.200-1STTN	4	C45 Q+T	14,0	28,0	30



DIAGRAMA DE CARGA ESTÁTICA PARA ESFUERZOS DE COMPRESIÓN
 STATIC LOAD CHARTS VALID FOR COMPRESSIVE LOADS

EB1 STOCK

SERIE ESTÁNDAR STANDARD SERIES

EB1.25.0475.202-1SPPN

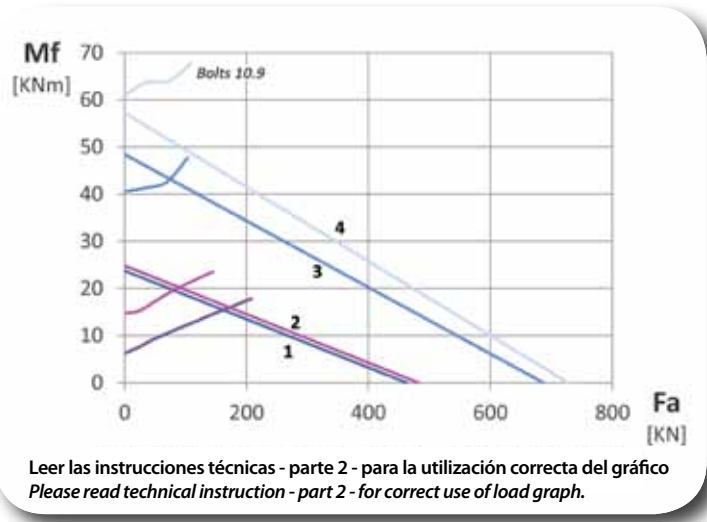
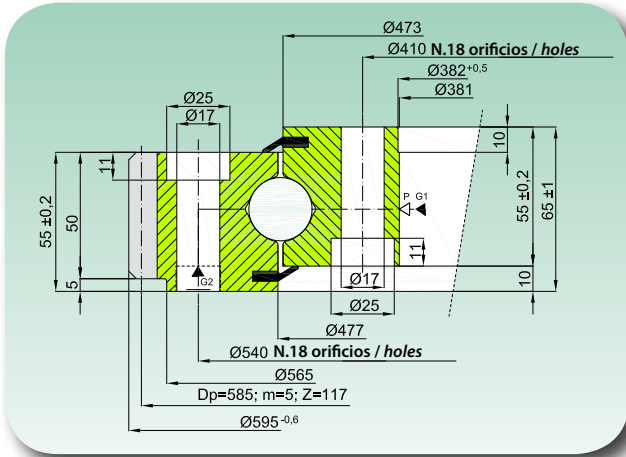

EB1.20.0662.200-1STTN

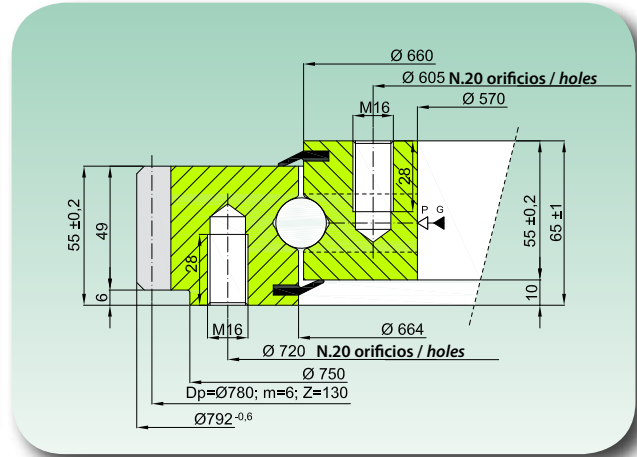

EB1.22.0758.201-1SPPN

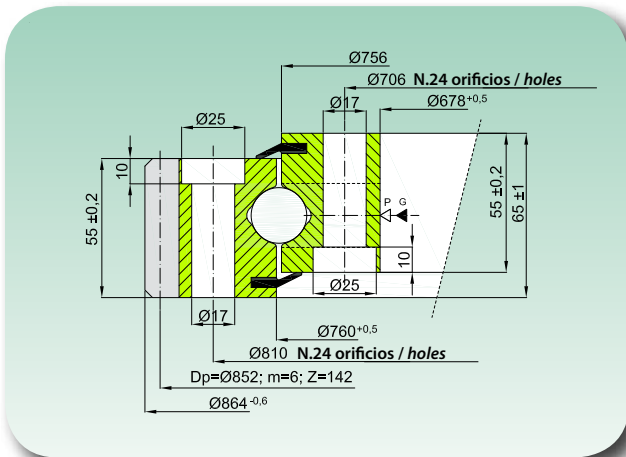

EB1.25.0854.200-1SPPN

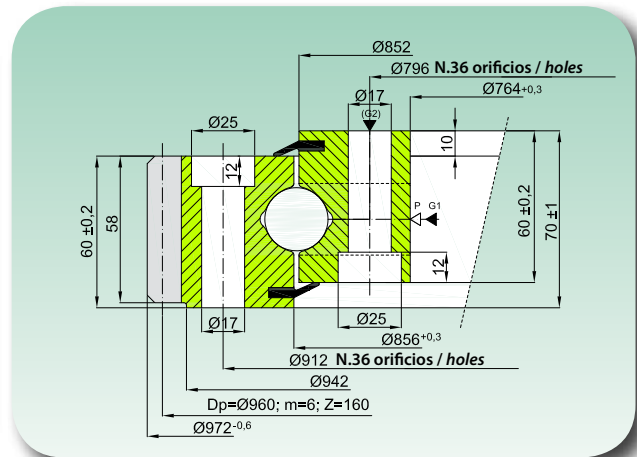

Código Code	Curva Curve	Material Material	Dentado Gear data		Peso Weight [Kg]
			fz nor [kN]	fz max [kN]	
EB1.25.0475.202-1SPPN	5	C45 Q+T	17,0	34,0	58
EB1.20.0662.200-1STTN	6	C45 Q+T	17,3	34,6	92
EB1.22.0758.201-1SPPN	7	C45 Q+T	17,3	34,6	80
EB1.25.0854.200-1SPPN	8	C45 Q+T	17,3	34,6	106



DIAGRAMA DE CARGA ESTÁTICA PARA ESFUERZOS DE COMPRESIÓN
STATIC LOAD CHARTS VALID FOR COMPRESSIVE LOADS

Leer las instrucciones técnicas - parte 2 - para la utilización correcta del gráfico
Please read technical instruction - part 2 - for correct use of load graph.

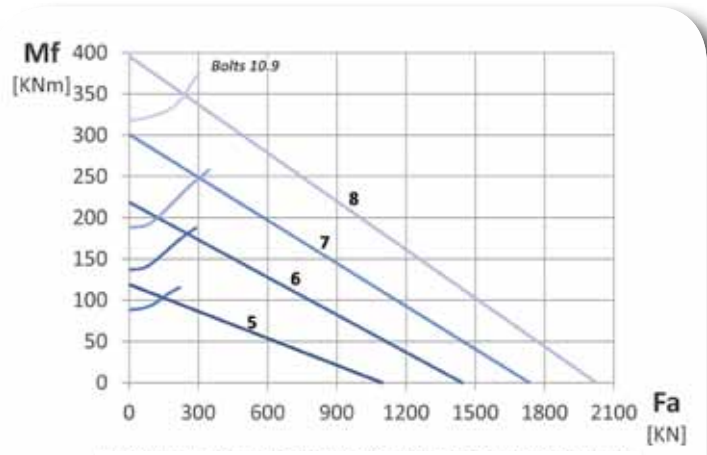

Coronas giratorias de una hilera de bolas, dentado interior

One row ball bearing, internal toothed

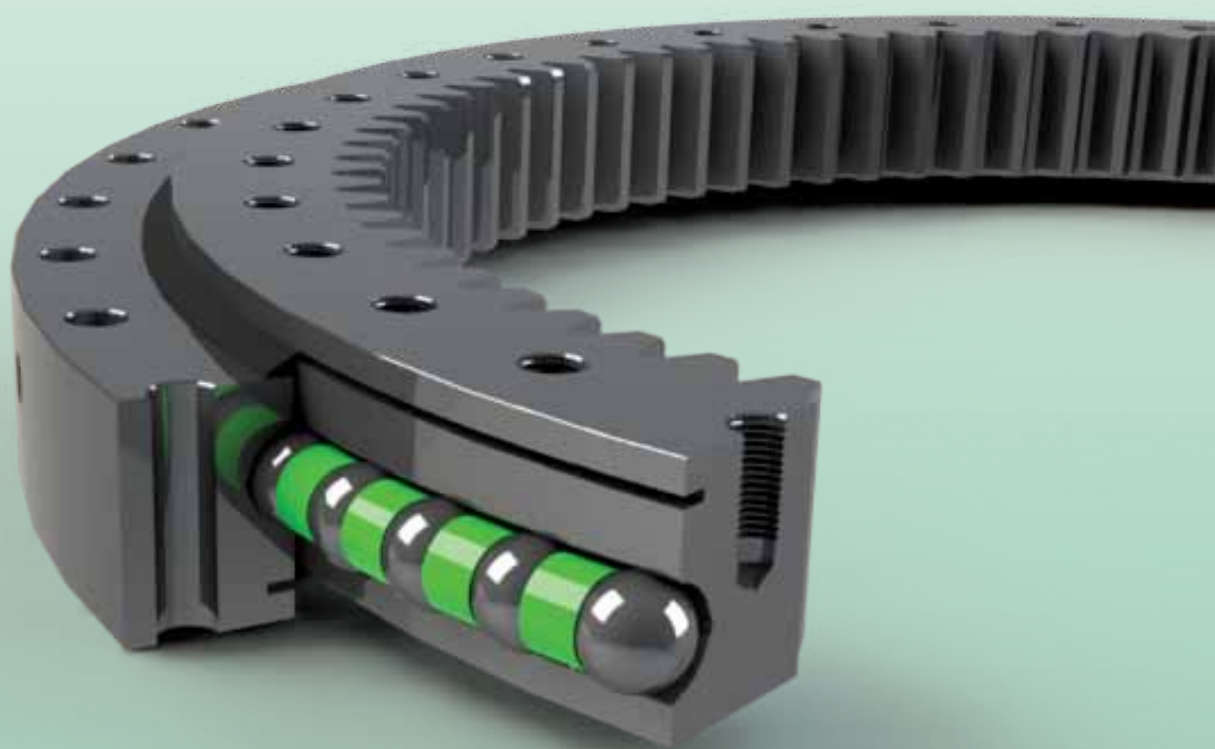

ZB1 SERIES

ZB1.20 S

SERIE ESTÁNDAR

STANDARD SERIES

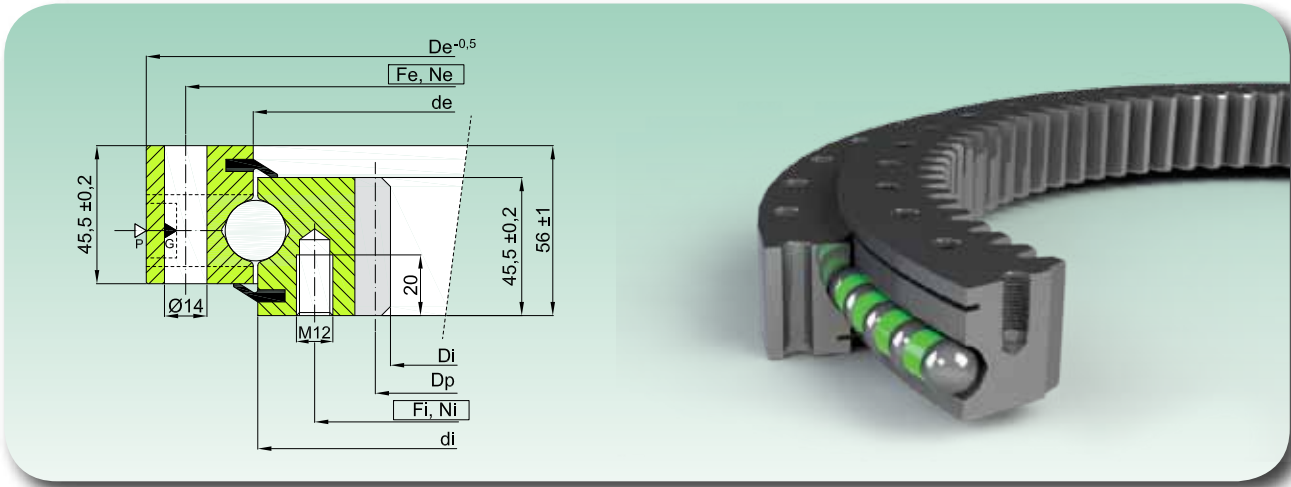

Código Code	Curva Curve	Dimensiones Dimensions				Orificios de fijación Fixing Holes				Dentado Gear data					Peso Weight [kg]
		De [mm]	de [mm]	di [mm]	Di [mm]	Fe [mm]	Ne [-]	Fi [mm]	Ni [-]	m [mm]	Z [-]	Dp [mm]	fz norm [kN]	fz max [kN]	
ZB1.20.0314.200-1SPTN	1	386	315,5	312,5	225	360	24	275	24	5	47	235	15,58	31,17	22
ZB1.20.0414.200-1SPTN	2	486	415,5	412,5	325	460	24	375	24	5	67	335	15,58	31,17	31
ZB1.20.0544.200-1SPTN	3	616	545,5	542,5	444	590	32	505	32	6	76	456	18,7	37,4	43
ZB1.20.0644.200-1SPTN	4	716	645,5	642,5	546	690	36	605	36	6	93	558	18,7	37,4	50
ZB1.20.0744.200-1SPTN	5	816	745,5	742,5	648	790	40	705	40	6	110	660	18,7	37,4	57
ZB1.20.0844.200-1SPTN	6	916	845,5	842,5	736	890	40	805	40	8	94	752	24,93	49,87	69
ZB1.20.0944.200-1SPTN	7	1016	945,5	942,5	840	990	44	905	44	8	107	856	24,93	49,87	75
ZB1.20.1094.200-1SPTN	8	1166	1095,5	1092,5	984	1140	48	1055	48	8	125	1000	24,93	49,87	91

- Material: C45Q+T
 - Juego axial máx. 0,35 mm - Juego radial máx. 0,25 mm
 - Llenos de grasa, protegidos por aceite y envueltos en resistente película plástica
 ▷ P=tapón inserción bolas / filling plug ▶ G=n.4 engrasadores M8X1 / n.4 greasers M8X1

- Material C45 Q+T
 - Axial clearance max. 0,35 mm - Radial clearance max. 0,25 mm
 - Full of grease, protected by oil and wrapped in resistant plastic film

Mf
Momento de inclinación equivalente [KNm]
Equivalent Tilting moment [KNm]



DIAGRAMA DE CARGA ESTÁTICA PARA ESFUERZOS DE COMPRESIÓN

STATIC LOAD CHARTS VALID FOR COMPRESSIVE LOADS

Fa

Carga axial equivalente [KN]
Equivalent axial load [KN]

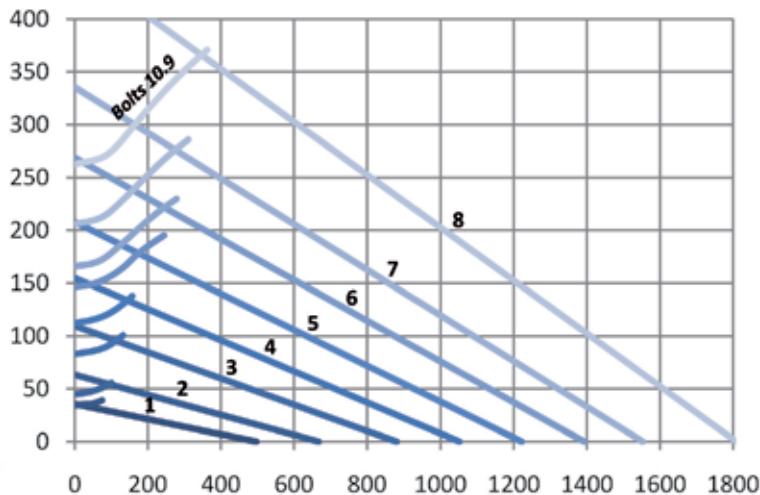
Leer las instrucciones técnicas - parte 2 - para la utilización correcta del gráfico

Please read technical instruction part 2 for correct use of load graph.

ZB1.20 P

SERIE DE PRECISIÓN

PRECISION SERIES

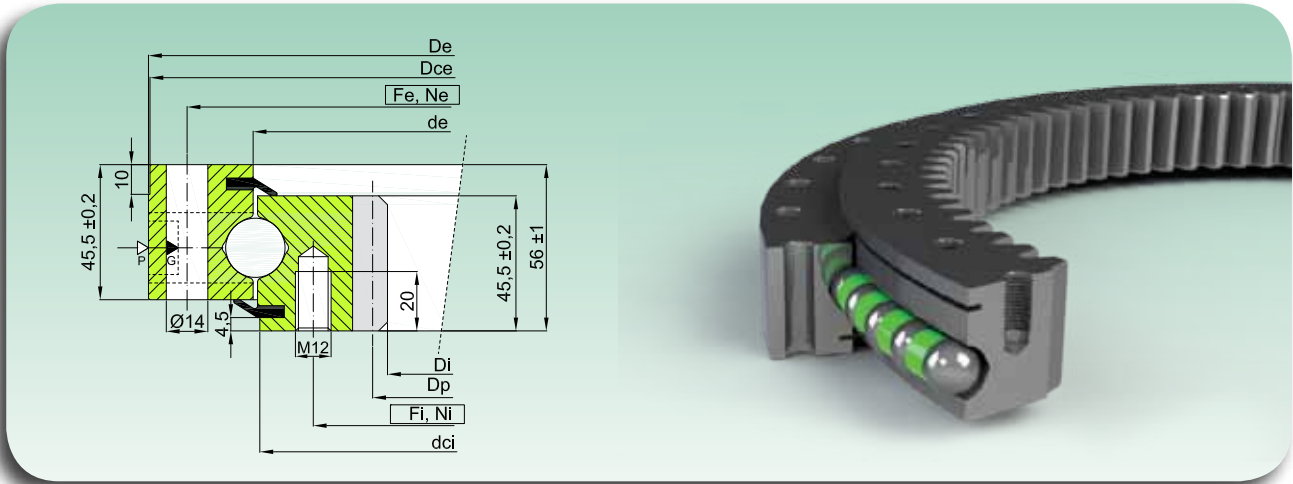

Código Code	Curva Curve	Dimensiones Dimensions				Orificios de fijación Fixing Holes				Dentado Gear data				Juego ax. y radial Axial and Radial Clearance	Peso Weight		
		De [mm]	Dce [mm]	de [mm]	dci [mm]	Di [mm]	Fe [mm]	Ne [-]	Fi [mm]	Ni [-]	m [mm]	Z [-]	Dp [mm]			fz norm [kN]	fz max [kN]
ZB1.20.0314.201-2SPTN	1	386	384,5 -0,09	315,5	311 -0,07	225	360	24	275	24	5	47	235	15,58	31,17	0 ÷ 0,03	22
ZB1.20.0414.201-2SPTN	2	486	484,5 -0,10	415,5	411 -0,09	325	460	24	375	24	5	67	335	15,58	31,17	0 ÷ 0,03	31
ZB1.20.0544.201-2SPTN	3	616	614,5 -0,11	545,5	541 -0,10	444	590	32	505	32	6	76	456	18,7	37,4	0 ÷ 0,03	43
ZB1.20.0644.201-2SPTN	4	716	714,5 -0,13	645,5	641 -0,11	546	690	36	605	36	6	93	558	18,7	37,4	0 ÷ 0,04	50
ZB1.20.0744.201-2SPTN	5	816	814,5 -0,14	745,5	741 -0,13	648	790	40	705	40	6	110	660	18,7	37,4	0 ÷ 0,04	57
ZB1.20.0844.201-2SPTN	6	916	914,5 -0,14	845,5	841 -0,13	736	890	40	805	40	8	94	752	24,93	49,87	0 ÷ 0,05	69
ZB1.20.0944.201-2SPTN	7	1016	1014,5 -0,17	945,5	941 -0,14	840	990	44	905	44	8	107	856	24,93	49,87	0 ÷ 0,05	75
ZB1.20.1094.201-2SPTN	8	1166	1164,5 -0,17	1095,5	1091 -0,17	984	1140	48	1055	48	8	125	1000	24,93	49,87	0 ÷ 0,06	91

- Material: C45Q+T

- Material C45 Q+T

- Llenos de grasa, protegidos por aceite y envueltos en resistente película plástica

- Full of grease, protected by oil and wrapped in resistant plastic film

▷ P=tapón inserción bolas / filling plug

▶ G= n.4 engrasadores M8X1 / n.4 greasers M8X1

Mf
Momento de inclinación equivalente [KNm]
Equivalent Tilting moment [KNm]



DIAGRAMA DE CARGA ESTÁTICA PARA ESFUERZOS DE COMPRESIÓN

STATIC LOAD CHARTS VALID FOR COMPRESSIVE LOADS

Fa

Carga axial equivalente [KN]
Equivalent axial load [KN]

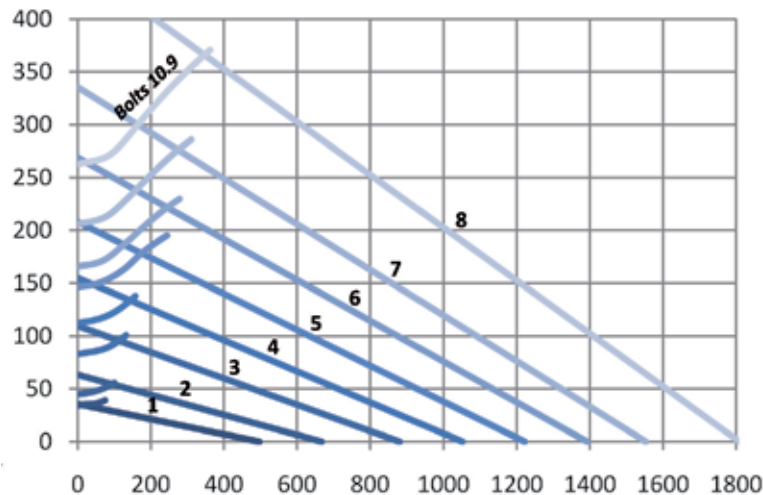
Leer las instrucciones técnicas - parte 2 - para la utilización correcta del gráfico

Please read technical instruction part 2 for correct use of load graph.

ZB1.25 S

SERIE ESTÁNDAR

STANDARD SERIES

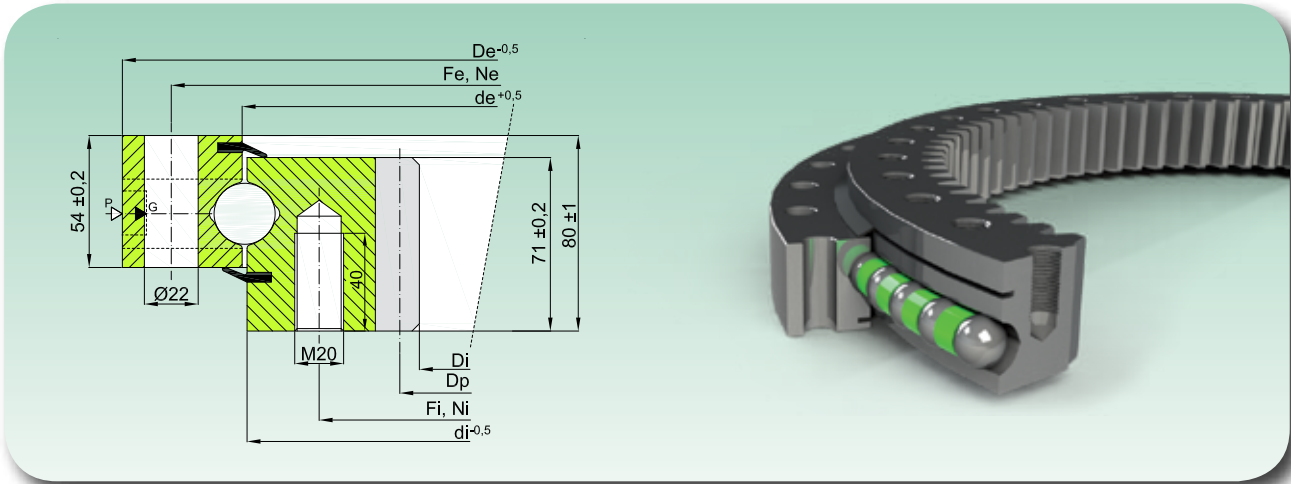

Código Code	Curva Curve	Dimensiones Dimensions				Orificios de fijación Fixing Holes				Dentado Gear data				Peso Weight [kg]	
		De [mm]	de [mm]	di [mm]	Di [mm]	Fe [mm]	Ne [-]	Fi [mm]	Ni [-]	m [mm]	Z [-]	Dp [mm]	fz norm [kN]		fz max [kN]
ZB1.25.0455.200-1SPTN	1	555	454	456	304	515	18	394	18	8	40	320	40,23	80,47	64
ZB1.25.0555.200-1SPTN	2	655	554	556	416	615	20	494	20	8	54	432	40,23	80,47	76
ZB1.25.0655.200-1SPTN	3	755	654	656	512	715	24	594	24	8	66	528	40,23	80,47	102
ZB1.25.0755.200-1SPTN	4	855	754	756	610	815	24	694	24	10	63	630	50,29	100,58	119
ZB1.25.0855.200-1SPTN	5	955	854	856	710	915	28	794	28	10	73	730	50,29	100,58	137
ZB1.25.0955.200-1SPTN	6	1055	954	956	810	1015	30	894	30	10	83	830	50,29	100,58	149
ZB1.25.1055.200-1SPTN	7	1155	1054	1056	910	1115	30	994	30	10	93	930	50,29	100,58	165
ZB1.25.1155.200-1SPTN	8	1255	1154	1156	1010	1215	36	1094	36	10	103	1030	50,29	100,58	180
ZB1.25.1255.200-1SPTN	9	1355	1254	1256	1110	1315	42	1194	42	10	113	1130	50,29	100,58	195
ZB1.25.1355.200-1SPTN	10	1455	1354	1356	1210	1415	42	1294	42	10	123	1230	50,29	100,58	212
ZB1.25.1455.200-1SPTN	11	1555	1454	1456	1310	1515	48	1394	48	10	133	1330	50,29	100,58	227

- Material: C45Q+T

- Juego axial máx. 0,40 mm - Juego radial máx. 0,30 mm

- Llenos de grasa, protegidos por aceite y envueltos en resistente película plástica

▷ P= tapón inserción bolas / filling plug

▶ G= n.4/6 engrasadores M10X1 / n.4/6greasers M10X1

- Material C45 Q+T

- Axial clearance max. 0,40 mm - Radial clearance max. 0,30 mm

- Full of grease, protected by oil and wrapped in resistant plastic film

Mf
Momento de inclinación equivalente [KNm]
Equivalent Tilting moment [KNm]

Leer las instrucciones técnicas - parte 2 - para la utilización correcta del gráfico

Please read technical instruction part 2 for correct use of load graph.



DIAGRAMA DE CARGA ESTÁTICA PARA ESFUERZOS DE COMPRESIÓN

STATIC LOAD CHARTS VALID FOR COMPRESSIVE LOADS

Fa

Carga axial equivalente [KN]
Equivalent axial load [KN]

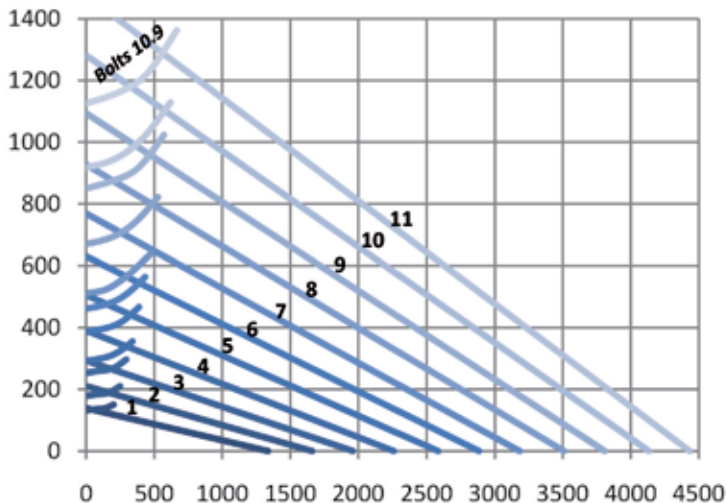
ZB1.25 P

SERIE DE PRECISIÓN

PRECISION SERIES

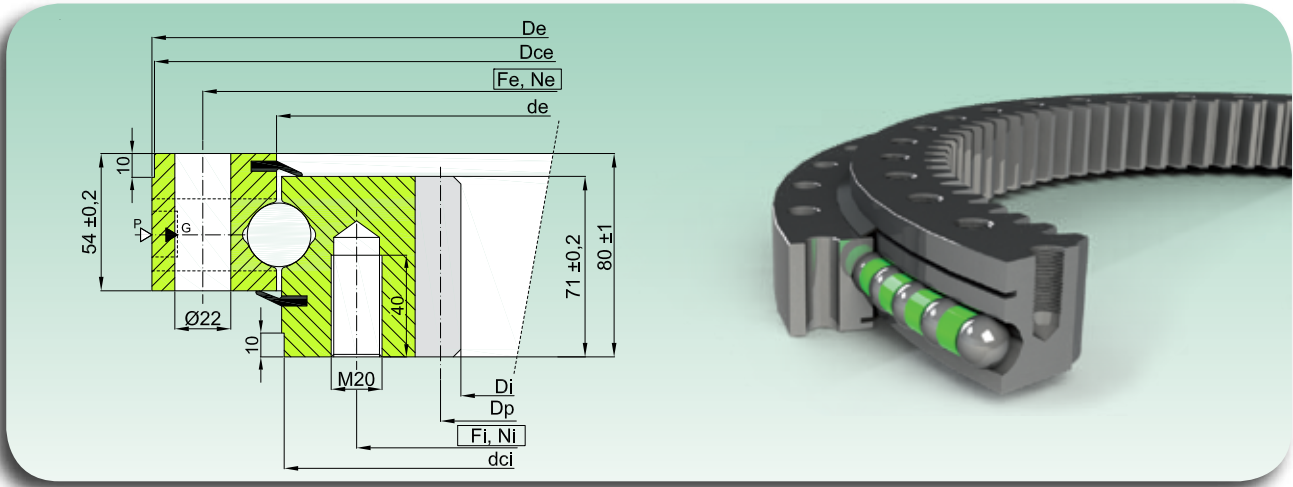

Código Code	Curva Curve	Dimensiones Dimensions				Orificios de fijación Fixing Holes				Dentado Gear data				Juego ax. y radial Axial and Radial Clearance	Peso Weight		
		De [mm]	Dce [mm]	de [mm]	dci [mm]	Di [mm]	Fe [mm]	Ne [-]	Fi [mm]	Ni [-]	m [mm]	Z [-]	Dp [mm]			fz norm [kN]	fz max [kN]
ZB1.25.0455.201-2SPTN	1	555	553 -0,11	454	455 -0,10	304	515	18	394	18	8	40	320	40,23	80,47	0 ÷ 0,03	64
ZB1.25.0555.201-2SPTN	2	655	653 -0,13	554	555 -0,11	416	615	20	494	20	8	54	432	40,23	80,47	0 ÷ 0,03	76
ZB1.25.0655.201-2SPTN	3	755	753 -0,14	654	655 -0,13	512	715	24	594	24	8	66	528	40,23	80,47	0 ÷ 0,03	102
ZB1.25.0755.201-2SPTN	4	855	853 -0,14	754	755 -0,14	610	815	24	694	24	10	63	630	50,29	100,58	0 ÷ 0,04	119
ZB1.25.0855.201-2SPTN	5	955	953 -0,14	854	855 -0,14	710	915	28	794	28	10	73	730	50,29	100,58	0 ÷ 0,04	137
ZB1.25.0955.201-2SPTN	6	1055	1053 -0,14	954	955 -0,14	810	1015	30	894	30	10	83	830	50,29	100,58	0 ÷ 0,05	149
ZB1.25.1055.201-2SPTN	7	1155	1153 -0,17	1054	1055 -0,14	910	1115	30	994	30	10	93	930	50,29	100,58	0 ÷ 0,05	165
ZB1.25.1155.201-2SPTN	8	1255	1253 -0,17	1154	1155 -0,17	1010	1215	36	1094	36	10	103	1030	50,29	100,58	0 ÷ 0,06	180
ZB1.25.1255.201-2SPTN	9	1355	1353 -0,17	1254	1255 -0,17	1110	1315	42	1194	42	10	113	1130	50,29	100,58	0 ÷ 0,07	195
ZB1.25.1355.201-2SPTN	10	1455	1453 -0,20	1354	1355 -0,17	1210	1415	42	1294	42	10	123	1230	50,29	100,58	0 ÷ 0,07	212
ZB1.25.1455.201-2SPTN	11	1555	1553 -0,20	1454	1455 -0,17	1310	1515	48	1394	48	10	133	1330	50,29	100,58	0 ÷ 0,07	227

- Material: C45Q+T

- Material C45 Q+T

- Llenos de grasa, protegidos por aceite y envueltos en resistente película plástica

- Full of grease, protected by oil and wrapped in resistant plastic film

▷ P= tapón inserción bolas / filling plug

▶ G= n.4/6 engrasadores M10X1 / n.4/6greasers M10X1

Mf
Momento de inclinación equivalente [KNm]
Equivalent Tilting moment [KNm]

Leer las instrucciones técnicas - parte 2 - para la utilización correcta del gráfico

Please read technical instruction part 2 for correct use of load graph.



DIAGRAMA DE CARGA ESTÁTICA PARA ESFUERZOS DE COMPRESIÓN

STATIC LOAD CHARTS VALID FOR COMPRESSIVE LOADS

Fa

Carga axial equivalente [KN]
Equivalent axial load [KN]

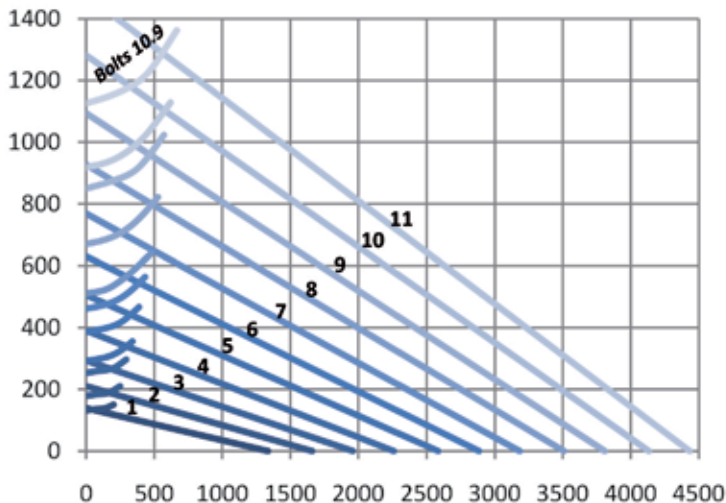
ZB1.25 R

SERIE ESTÁNDAR

STANDARD SERIES

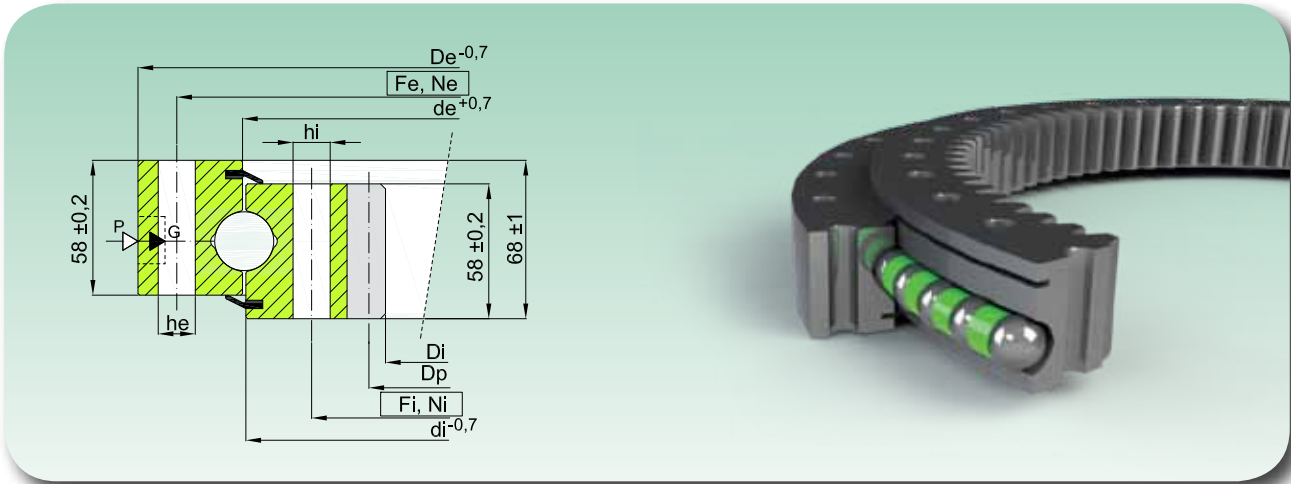

Código Code	Curva Curve	Dimensiones Dimensions				Orificios de fijación Fixing Holes						Dentado Gear data				Peso Weight [kg]	
		De [mm]	de [mm]	di [mm]	Di [mm]	Fe [mm]	Ne [-]	he [mm]	Fi [mm]	Ni [-]	hi [mm]	m [mm]	Z [-]	Dp [mm]	fz norm [kN]		fz max [kN]
ZB1.25.1204.400-1SPPN	1	1289	1206	1202	1072	1257	45	16	1151	45	16	10	108	1080	48,33	96,67	145
ZB1.25.1314.400-1SPPN	2	1399	1316	1312	1182	1367	50	16	1261	50	16	10	119	1190	48,33	96,67	159
ZB1.25.1424.400-1SPPN	3	1509	1426	1422	1292	1477	54	16	1371	54	16	10	130	1300	48,33	96,67	172
ZB1.25.1534.400-1SPPN	4	1619	1536	1532	1402	1587	60	16	1481	60	16	10	141	1410	48,33	96,67	186
ZB1.25.1644.400-1SPPN	5	1752	1646	1642	1495	1708	54	22	1580	54	22	10	150	1500	48,33	96,67	236
ZB1.25.1754.400-1SPPN	6	1862	1756	1752	1605	1818	60	22	1690	60	22	10	161	1610	48,33	96,67	252
ZB1.25.1904.400-1SPPN	7	2012	1906	1902	1729	1968	64	22	1840	64	22	14	124	1736	67,67	135,33	299

- Material: 42CrMo4 Q+T - Material 42CrMo4 Q+T
 - Juego axial máx. 0,40 mm - Juego radial máx. 0,30 mm - Axial clearance max. 0,40 mm - Radial clearance max. 0,30 mm
 - Llenos de grasa, protegidos por aceite y envueltos en resistente película plástica - Full of grease, protected by oil and wrapped in resistant plastic film
 ▷ P=tapón inserción bolas / filling plug ▶ G= n.6 engrasadores M8X1 / n.6 greasers M8X1.

Mf
Momento de inclinación equivalente [KNm]
 Equivalent Tilting moment [KNm]

Leer las instrucciones técnicas - parte 2 - para la utilización correcta del gráfico

Please read technical instruction part 2 for correct use of load graph.



DIAGRAMA DE CARGA ESTÁTICA PARA ESFUERZOS DE COMPRESIÓN

STATIC LOAD CHARTS VALID FOR COMPRESSIVE LOADS

Fa
Carga axial equivalente [KN]
 Equivalent axial load [KN]

ZB1.50 S

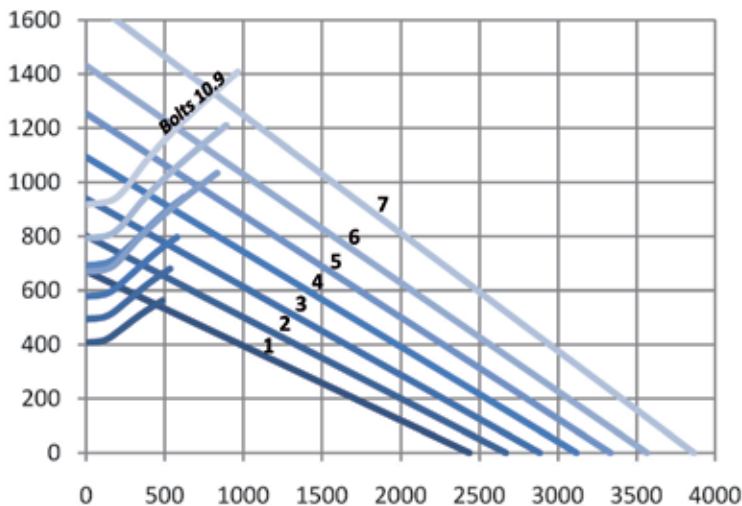
SERIE DE PRECISIÓN

PRECISION SERIES

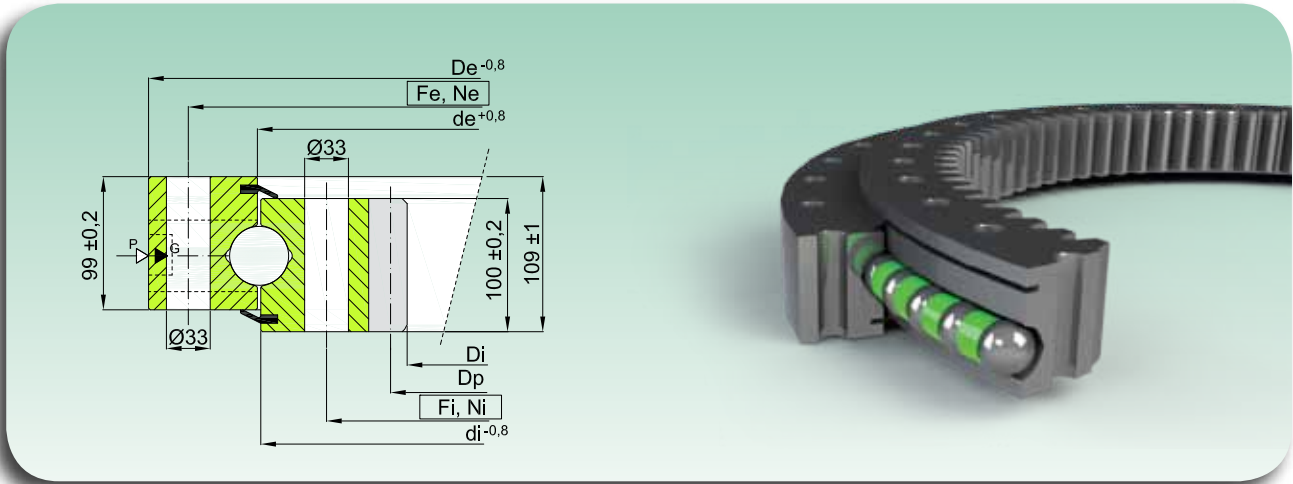

Código Code	Curva Curve	Dimensiones Dimensions					Orificios de fijación Fixing Holes			Dentado Gear data					Peso Weight [kg]	
		De [mm]	de [mm]	di [mm]	Di [mm]	Fe [mm]	Ne [-]	Fi [mm]	Ni [-]	m [mm]	Z [-]	xm [mm]	Dp [mm]	fz norm [kN]		fz max [kN]
ZB1.50.1800.400-1SPPN	1	1971	1798	1802	1554	1905	36	1695	36	14	112	-7	1568	128,5	257	762
ZB1.50.2000.400-1SPPN	2	2171	1998	2002	1764	2105	40	1895	40	14	127	-7	1778	128,5	257	843
ZB1.50.2240.400-1SPPN	3	2411	2238	2242	1984	2345	48	2135	48	16	125	-8	2000	146,8	293,6	961
ZB1.50.2490.400-1SPPN	4	2661	2488	2492	2240	2595	54	2385	54	16	141	-8	2256	146,8	293,6	1053
ZB1.50.2800.400-1SPPN	5	2971	2798	2802	2544	2905	60	2695	60	16	160	-8	2560	146,8	293,6	1205

- Material: 42CrMo4 Q+T

- Juego axial máx. 0,40 mm - Juego radial máx. 0,30 mm

- Llenos de grasa, protegidos por aceite y envueltos en resistente película plástica

▷ P=tapón inserción bolas / filling plug

- Material 42CrMo4 Q+T

- Axial clearance max. 0,40 mm - Radial clearance max. 0,30 mm

- Full of grease, protected by oil and wrapped in resistant plastic film

▷ G= n.6 engrasadores M8X1 / n.6 greasers M8X1.

Mf
Momento de inclinación equivalente [KNm]
Equivalent Tilting moment [KNm]

Leer las instrucciones técnicas - parte 2 - para la utilización correcta del gráfico

Please read technical instruction part 2 for correct use of load graph.



DIAGRAMA DE CARGA ESTÁTICA PARA ESFUERZOS DE COMPRESIÓN

STATIC LOAD CHARTS VALID FOR COMPRESSIVE LOADS

Fa

Carga axial equivalente [KN]
Equivalent axial load [KN]

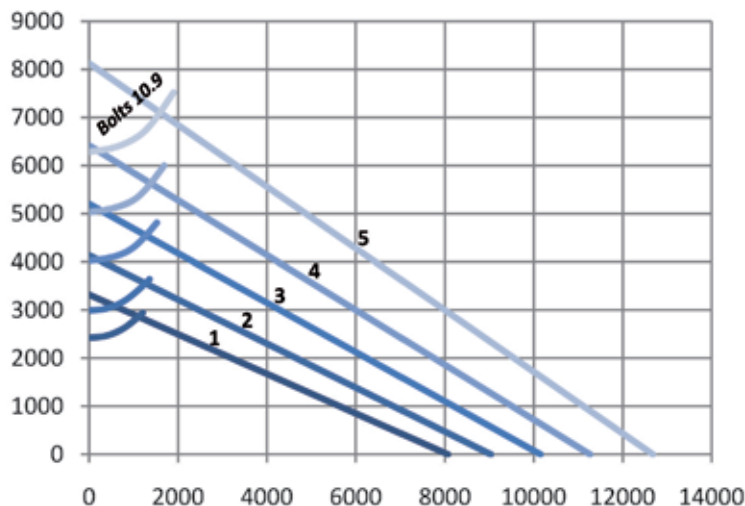
Equivalent axial load [KN]

ZB1 STOCK

SERIE ESTÁNDAR

STANDARD SERIES

ZB1.16.0260.400-1SPPN

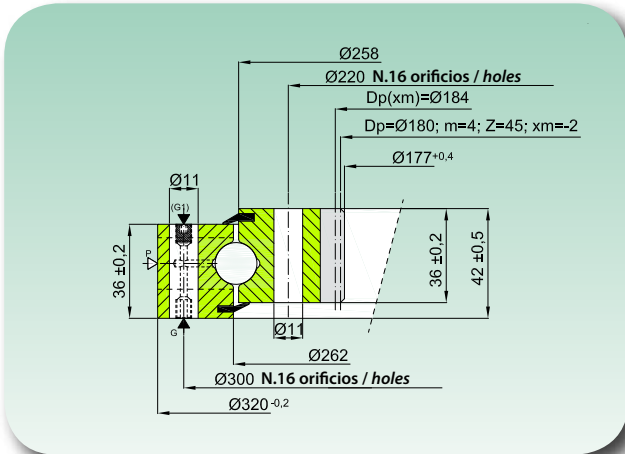

ZB1.20.0310.200-2SPTN

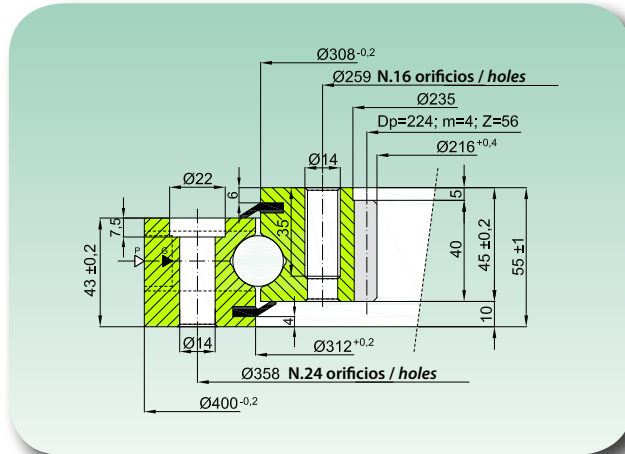

ZB1.16.0400.200-1RTTN

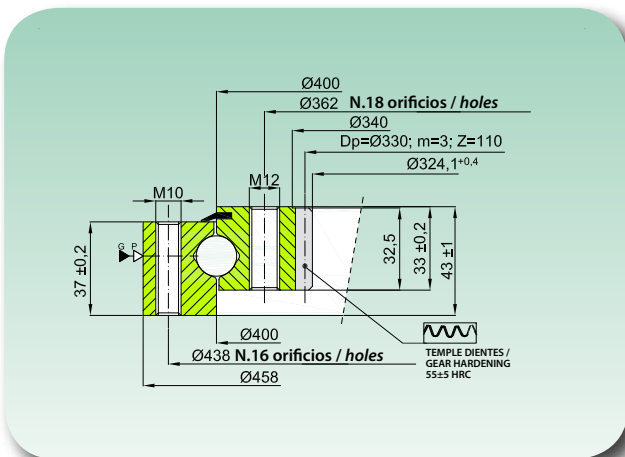

ZB1.20.0465.200-1RPTN

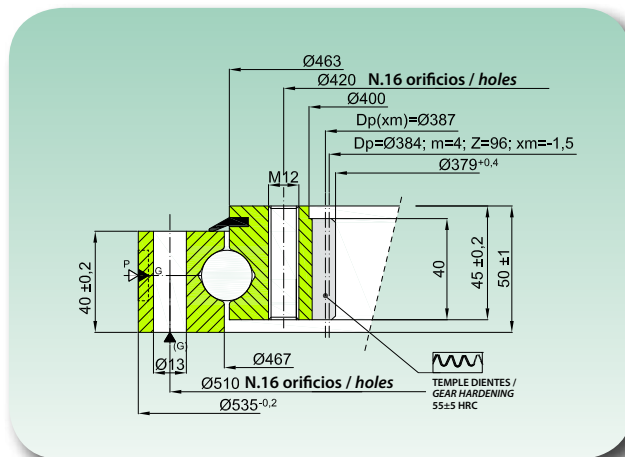

Código Code	Curva Curve	Material Material	Dentado Gear data		Peso Weight [Kg]
			fz nor [kN]	fz max [kN]	
ZB1.16.0260.400-1SPPN	1	42CrMo4 Q+T	11,1	22,2	13
ZB1.20.0310.200-2SPTN	2	C45 Q+T	7,2	14,4	26,5
ZB1.16.0400.200-1RTTN	3	C45 Q+T	5,6	11,2	19
ZB1.20.0465.200-1RPTN	4	C45 Q+T	11,1	22,2	17



DIAGRAMA DE CARGA ESTÁTICA PARA ESFUERZOS DE COMPRESIÓN
 STATIC LOAD CHARTS VALID FOR COMPRESSIVE LOADS

Leer las instrucciones técnicas - parte 2 - para la utilización correcta del gráfico
 Please read technical instruction - part 2 - for correct use of load graph.

ZB1 STOCK

SERIE ESTÁNDAR

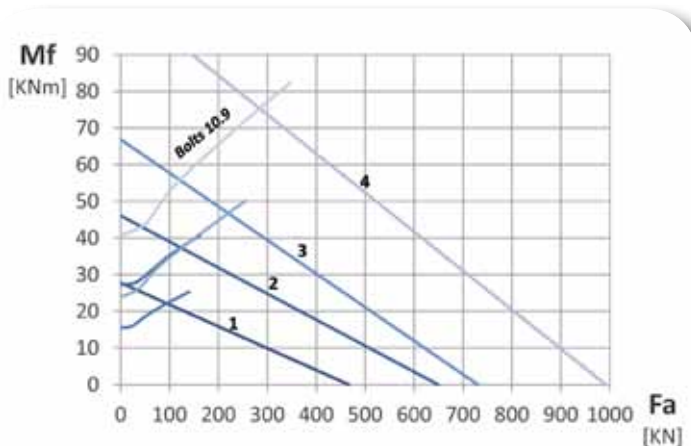
STANDARD SERIES

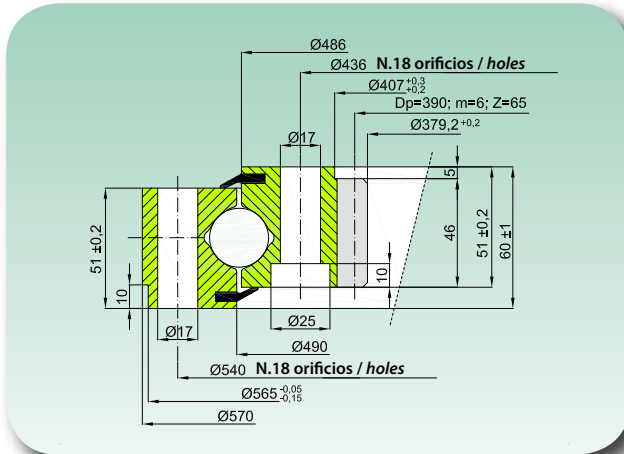
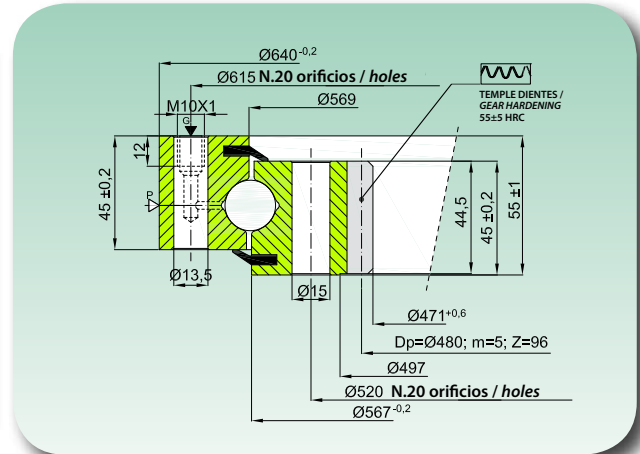
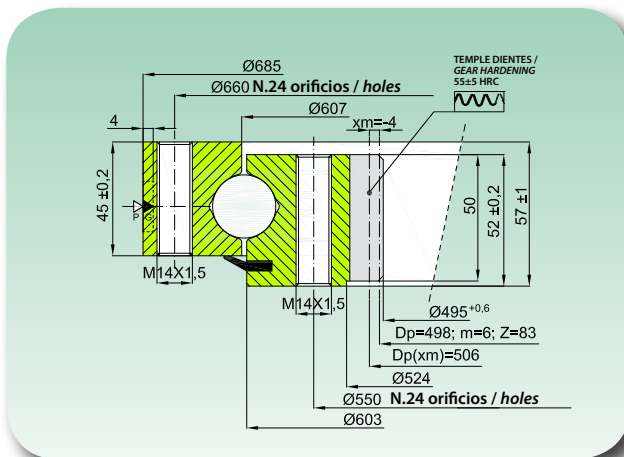
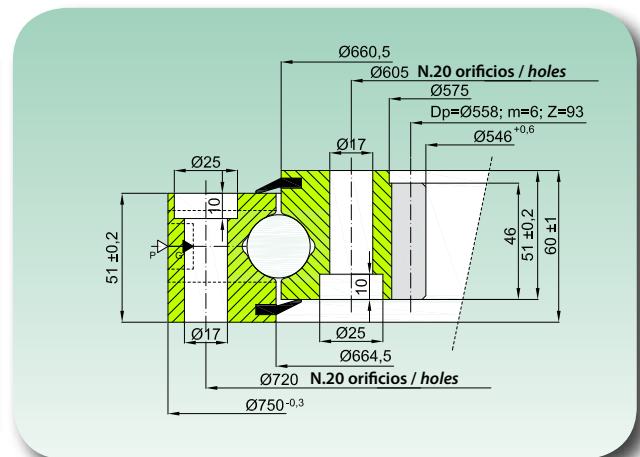
ZB1.25.0488.200-2SPPN

ZB1.20.0568.200-2RPPN

ZB1.20.0605.200-1RTTN

ZB1.25.0663.200-1SPPN

Código Code	Curva Curve	Material Material	Dentado Gear data		Peso Weight [Kg]
			fz nor [kN]	fz max [kN]	
ZB1.25.0488.200-2SPPN	5	C45 Q+T	17,2	34,4	46
ZB1.20.0568.200-2RPPN	6	C45 Q+T	15,7	31,3	45
ZB1.20.0605.200-1RTTN	7	C45 Q+T	24,0	48,0	61
ZB1.25.0663.200-1SPPN	8	C45 Q+T	19,5	39,0	68



DIAGRAMA DE CARGA ESTÁTICA PARA ESFUERZOS DE COMPRESIÓN
 STATIC LOAD CHARTS VALID FOR COMPRESSIVE LOADS

Leer las instrucciones técnicas - parte 2 - para la utilización correcta del gráfico
 Please read technical instruction - part 2 - for correct use of load graph.

ZB1 STOCK

SERIE ESTÁNDAR STANDARD SERIES

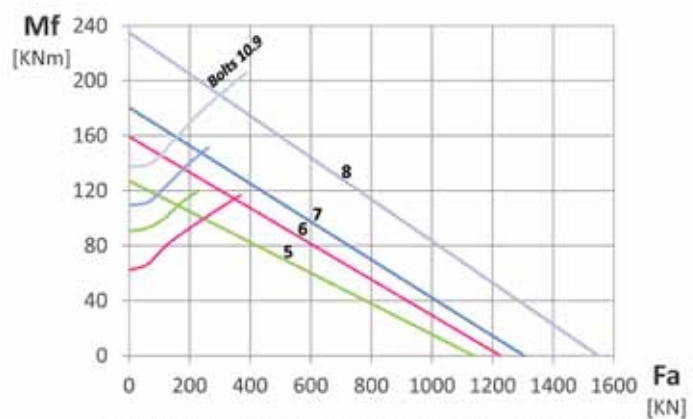
ZB1.25.0663.201-1SPPN

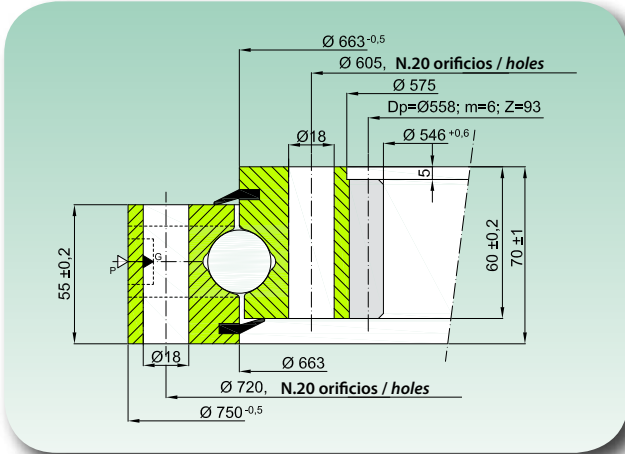

ZB1.25.0763.200-1SPPN

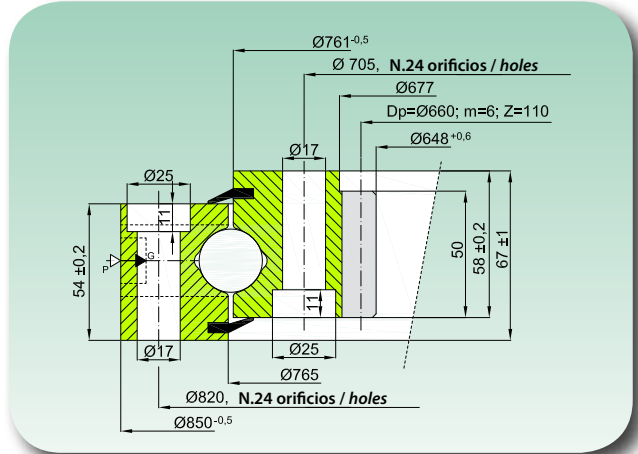

ZB1.25.0762.200-1SPPN

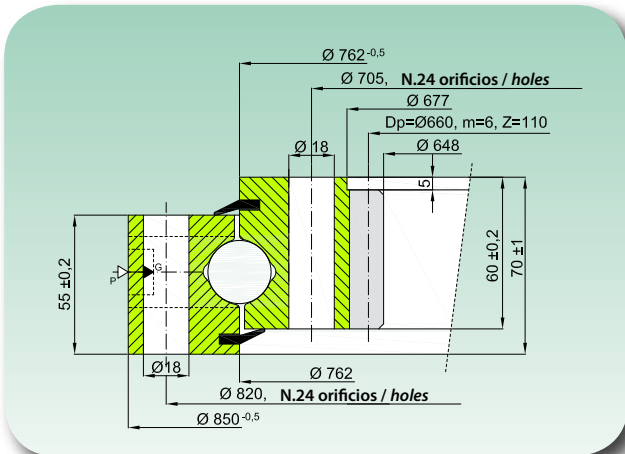

ZB1.25.0763.202-1RPTN

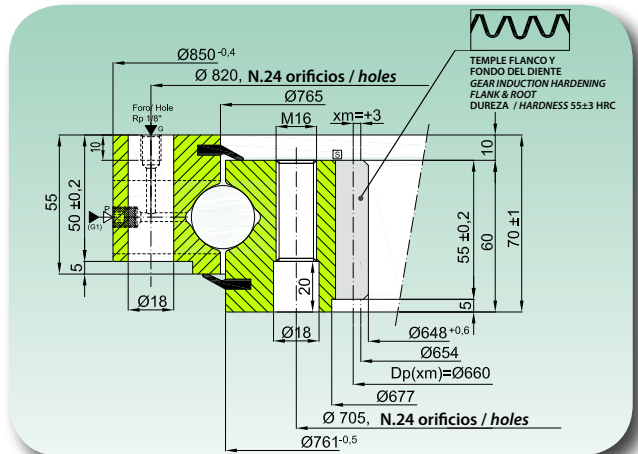

Código Code	Curva Curve	Material Material	Dentado Gear data		Peso Weight [Kg]
			fz nor [kN]	fz max [kN]	
ZB1.25.0663.201-1SPPN	9	C45 Q+T	19,5	39,0	76
ZB1.25.0763.200-1SPPN	10	C45 Q+T	19,5	39,0	85
ZB1.25.0762.200-1SPPN	10	C45 Q+T	19,5	39,0	91
ZB1.25.0763.202-1RPTN	10	C45 Q+T	25,0	50,0	85



DIAGRAMA DE CARGA ESTÁTICA PARA ESFUERZOS DE COMPRESIÓN
STATIC LOAD CHARTS VALID FOR COMPRESSIVE LOADS

Leer las instrucciones técnicas - parte 2 - para la utilización correcta del gráfico
Please read technical instruction - part 2 - for correct use of load graph.

ZB1 STOCK

SERIE ESTÁNDAR

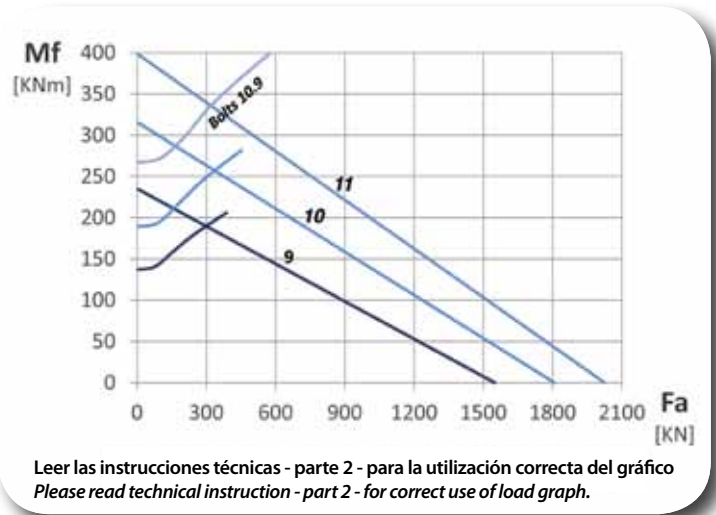
STANDARD SERIES

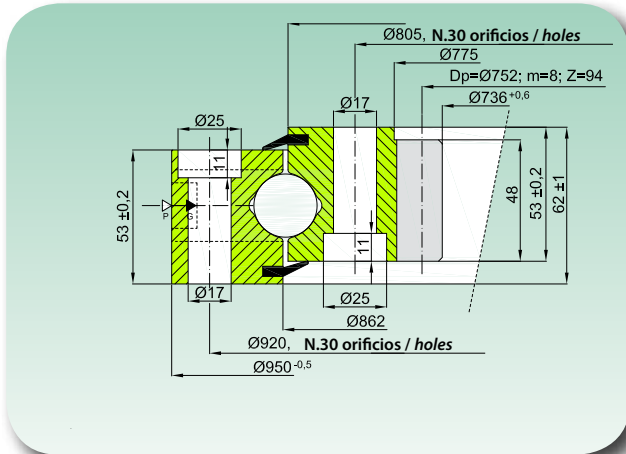
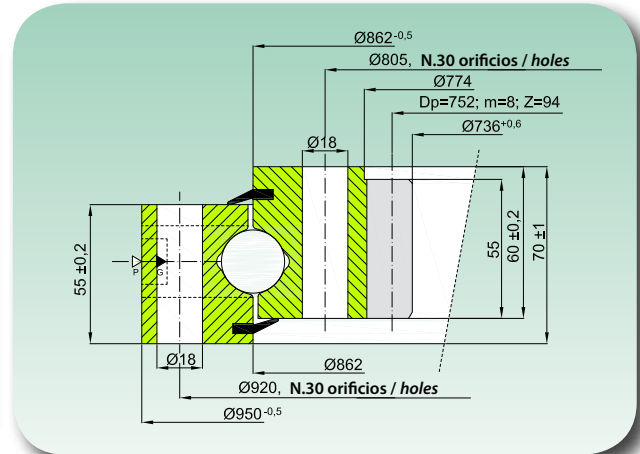
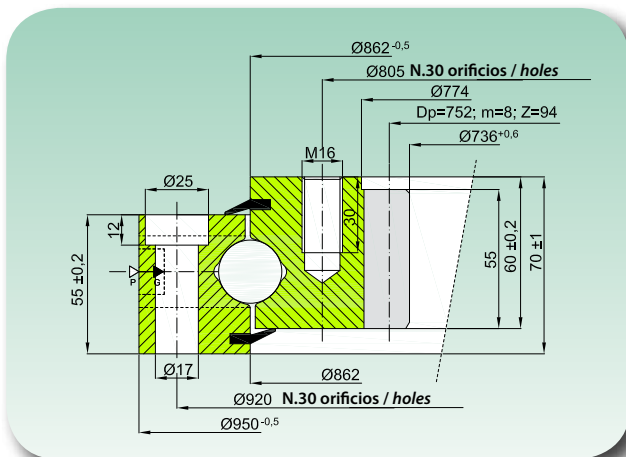
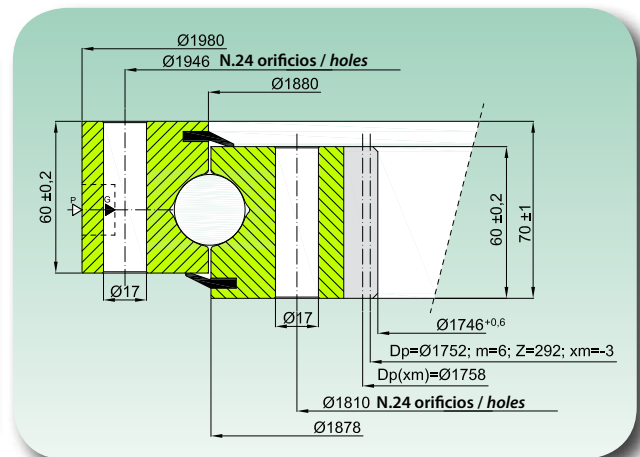
ZB1.25.0860.200-1SPPN

ZB1.25.0862.200-1SPPN

ZB1.25.0862.201-1SPTN

ZB1.28.1879.200-1SPPN

Código Code	Curva Curve	Material Material	Dentado Gear data		Peso Weight [Kg]
			fz nor [kN]	fz max [kN]	
ZB1.25.0860.200-1SPPN	11	C45 Q+T	27,0	54,0	95
ZB1.25.0862.200-1SPPN	11	C45 Q+T	27,0	54,0	108
ZB1.25.0862.201-1SPTN	11	C45 Q+T	27,0	54,0	115
ZB1.28.1879.200-1SPPN	12	C45 Q+T	19,5	39,0	290



DIAGRAMA DE CARGA ESTÁTICA PARA ESFUERZOS DE COMPRESIÓN
 STATIC LOAD CHARTS VALID FOR COMPRESSIVE LOADS

Leer las instrucciones técnicas - parte 2 - para la utilización correcta del gráfico
 Please read technical instruction - part 2 - for correct use of load graph.



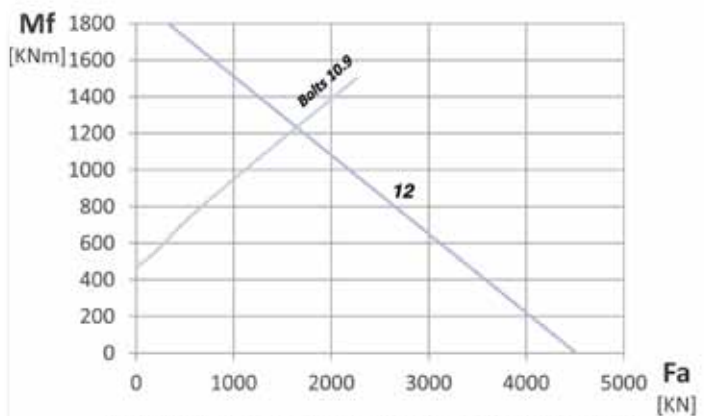

Coronas giratorias de una hilera de bolas, sin dentado

One row ball bearing, untoothed

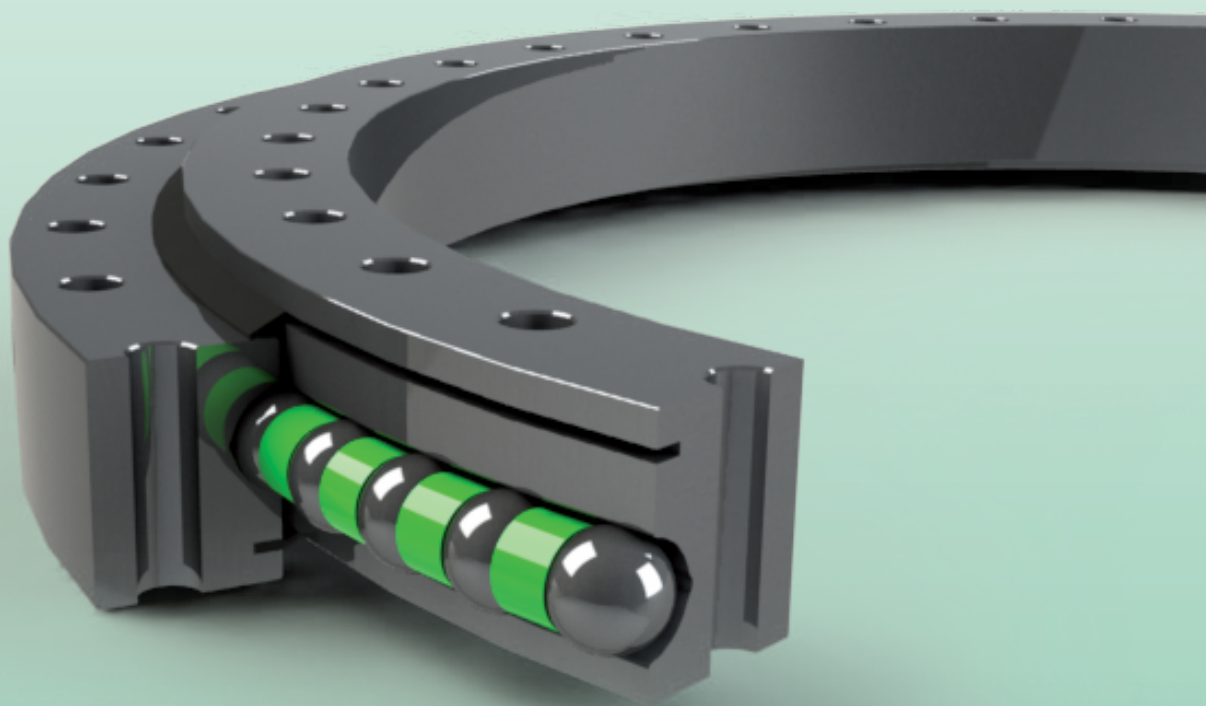

NB1 SERIES

NB1.20 S

SERIE ESTÁNDAR

STANDARD SERIES

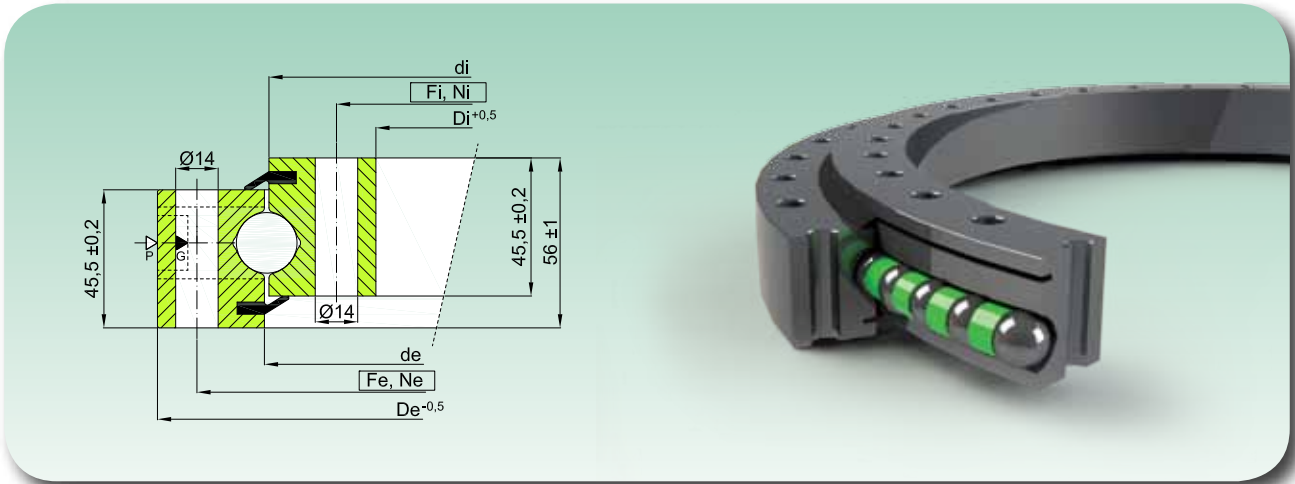

Código Code	Curva Curve	Dimensiones Dimensions				Orificios de fijación Fixing Holes				Peso Weight [kg]
		De [mm]	de [mm]	di [mm]	Di [mm]	Fe [mm]	Ne [-]	Fi [mm]	Ni [-]	
NB1.20.0314.200-1PPN	1	386	315,5	312,5	242	360	20	268	20	21
NB1.20.0414.200-1PPN	2	486	415,5	412,5	342	460	24	368	24	29
NB1.20.0544.200-1PPN	3	616	545,5	542,5	472	590	32	498	32	37
NB1.20.0644.200-1PPN	4	716	645,5	642,5	572	690	36	598	36	44
NB1.20.0744.200-1PPN	5	816	745,5	742,5	672	790	40	698	40	52
NB1.20.0844.200-1PPN	6	916	845,5	842,5	772	890	40	798	40	59
NB1.20.0944.200-1PPN	7	1016	945,5	942,5	872	990	44	898	44	66
NB1.20.1094.200-1PPN	8	1166	1095,5	1092,5	1022	1140	48	1048	48	77

- Material: C45Q+T

- Juego axial máx. 0,35 mm - Juego radial máx. 0,25 mm

- Llenos de grasa, protegidos por aceite y envueltos en resistente película plástica

▷ P= tapón inserción bolas / filling plug

▶ G= n.4 engrasadores M8X1 / n.4 greasers M8X1

- Material C45 Q+T

- Axial clearance max. 0,35 mm - Radial clearance max. 0,25 mm

- Full of grease, protected by oil and wrapped in resistant plastic film

Mf
Momento de inclinación equivalente [KNm]
Equivalent Tilting moment [KNm]



DIAGRAMA DE CARGA ESTÁTICA PARA ESFUERZOS DE COMPRESIÓN

STATIC LOAD CHARTS VALID FOR COMPRESSIVE LOADS

Fa

Carga axial equivalente [KN]
Equivalent axial load [KN]

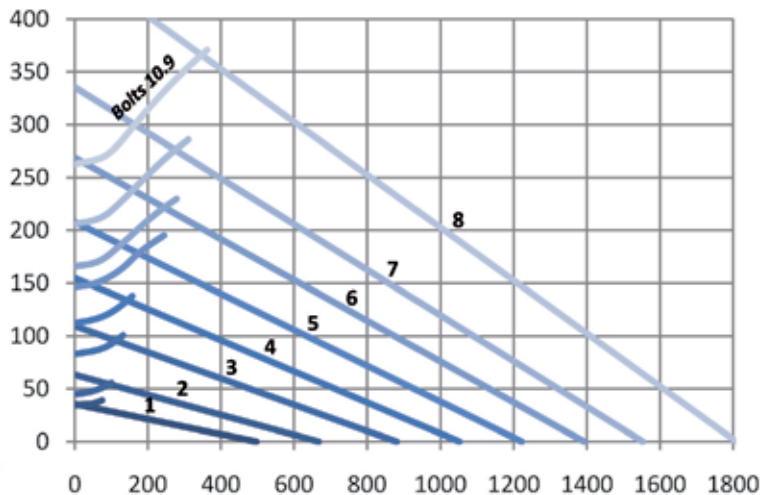
Leer las instrucciones técnicas - parte 2 - para la utilización correcta del gráfico

Please read technical instruction part 2 for correct use of load graph.

NB1.20 P

SERIE DE PRECISIÓN

PRECISION SERIES

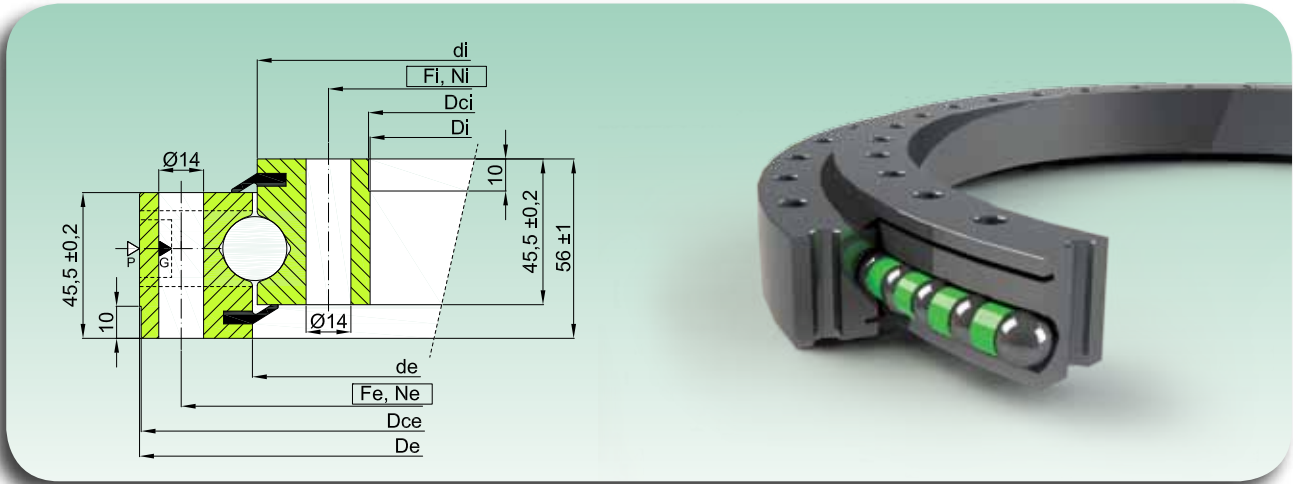

Código Code	Curva Curve	Dimensiones Dimensions						Orificios de fijación Fixing Holes				Juego ax. y radial Axial and Radial Clearance	Peso Weight
		De [mm]	Dce [mm]	de [mm]	di [mm]	Dci [mm]	Di [mm]	Fe [mm]	Ne [-]	Fi [mm]	Ni [-]		
NB1.20.0314.201-2PPN	1	386	384,5 -0,09	315,5	312,5	243,5 +0,07	242	360	20	268	20	0 ÷ 0,03	21
NB1.20.0414.201-2PPN	2	486	484,5 -0,10	415,5	412,5	343,5 +0,09	342	460	24	368	24	0 ÷ 0,03	29
NB1.20.0544.201-2PPN	3	616	614,5 -0,11	545,5	542,5	473,5 +0,10	472	590	32	498	32	0 ÷ 0,03	37
NB1.20.0644.201-2PPN	4	716	714,5 -0,13	645,5	642,5	573,5 +0,11	572	690	36	598	36	0 ÷ 0,04	44
NB1.20.0744.201-2PPN	5	816	814,5 -0,14	745,5	742,5	673,5 +0,13	672	790	40	698	40	0 ÷ 0,04	52
NB1.20.0844.201-2PPN	6	916	914,5 -0,14	845,5	842,5	773,5 +0,13	772	890	40	798	40	0 ÷ 0,05	59
NB1.20.0944.201-2PPN	7	1016	1014,5 -0,17	945,5	942,5	873,5 +0,14	872	990	44	898	44	0 ÷ 0,05	66
NB1.20.1094.201-2PPN	8	1166	1164,5 -0,17	1095,5	1092,5	1023,5 +0,17	1022	1140	48	1048	48	0 ÷ 0,06	77

- Material: C45Q+T

- Material C45 Q+T

- Llenos de grasa, protegidos por aceite y envueltos en resistente película plástica

- Full of grease, protected by oil and wrapped in resistant plastic film

▷ P=tapón inserción bolas / filling plug

▶ G= n.4 engrasadores M8X1 / n.4 greasers M8X1

Mf
Momento de inclinación equivalente [KNm]
Equivalent Tilting moment [KNm]



DIAGRAMA DE CARGA ESTÁTICA PARA ESFUERZOS DE COMPRESIÓN

STATIC LOAD CHARTS VALID FOR COMPRESSIVE LOADS

Fa

Carga axial equivalente [KN]
Equivalent axial load [KN]

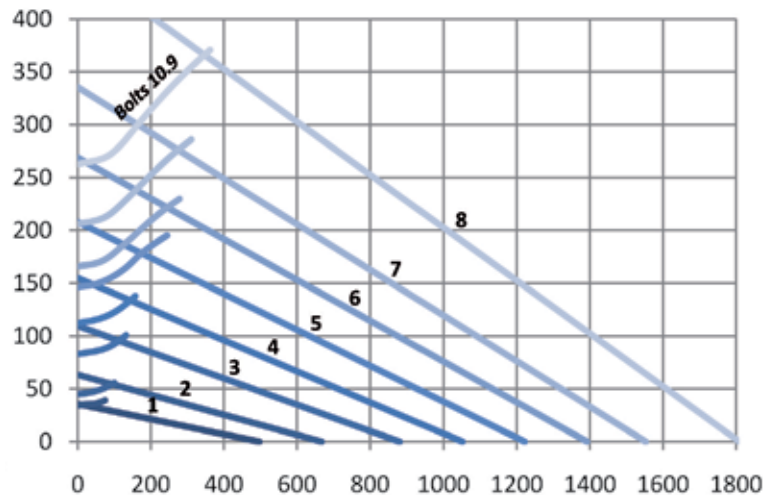
Leer las instrucciones técnicas - parte 2 - para la utilización correcta del gráfico

Please read technical instruction part 2 for correct use of load graph.

NB1.25 S

SERIE ESTÁNDAR

STANDARD SERIES

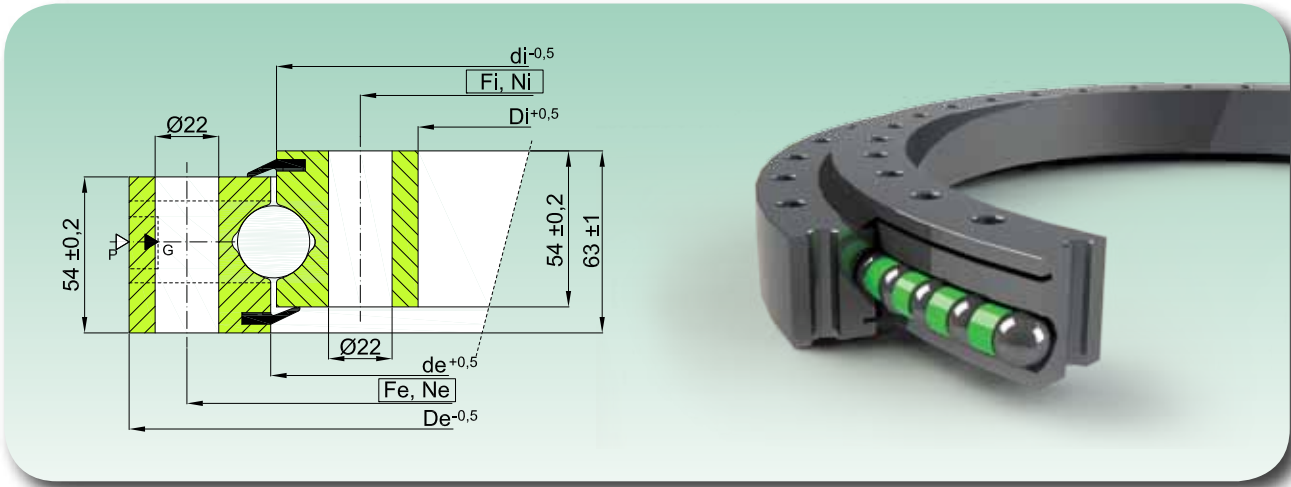

Código Code	Curva Curve	Dimensiones Dimensions				Orificios de fijación Fixing Holes				Peso Weight [kg]
		De [mm]	de [mm]	di [mm]	Di [mm]	Fe [mm]	Ne [-]	Fi [mm]	Ni [-]	
NB1.25.0455.200-1PPN	1	555	454	456	355	515	18	395	18	53
NB1.25.0555.200-1PPN	2	655	554	556	455	615	20	495	20	65
NB1.25.0655.200-1PPN	3	755	654	656	555	715	24	595	24	76
NB1.25.0755.200-1PPN	4	855	754	756	655	815	24	695	24	90
NB1.25.0855.200-1PPN	5	955	854	856	755	915	28	795	28	101
NB1.25.0955.200-1PPN	6	1055	954	956	855	1015	30	895	30	115
NB1.25.1055.200-1PPN	7	1155	1054	1056	955	1115	30	995	30	128
NB1.25.1155.200-1PPN	8	1255	1154	1156	1055	1215	36	1095	36	139
NB1.25.1255.200-1PPN	9	1355	1254	1256	1155	1315	42	1195	42	150
NB1.25.1355.200-1PPN	10	1455	1354	1356	1255	1415	42	1295	42	163
NB1.25.1455.200-1PPN	11	1555	1454	1456	1355	1515	48	1395	48	174

- Material: C45Q+T
 - Juego axial máx. 0,40 mm - Juego radial máx. 0,30 mm
 - Llenos de grasa, protegidos por aceite y envueltos en resistente película plástica
 ▷ P=tapón inserción bolas / filling plug ▶ G=n.4/6 engrasadores M10X1 / n.4/6greasers M10X1

- Material C45 Q+T
 - Axial clearance max. 0,40 mm - Radial clearance max. 0,30 mm
 - Full of grease, protected by oil and wrapped in resistant plastic film

Mf
Momento de inclinación equivalente [KNm]
Equivalent Tilting moment [KNm]



DIAGRAMA DE CARGA ESTÁTICA PARA ESFUERZOS DE COMPRESIÓN

STATIC LOAD CHARTS VALID FOR COMPRESSIVE LOADS

Fa
Carga axial equivalente [KN]
Equivalent axial load [KN]

Leer las instrucciones técnicas - parte 2 - para la utilización correcta del gráfico

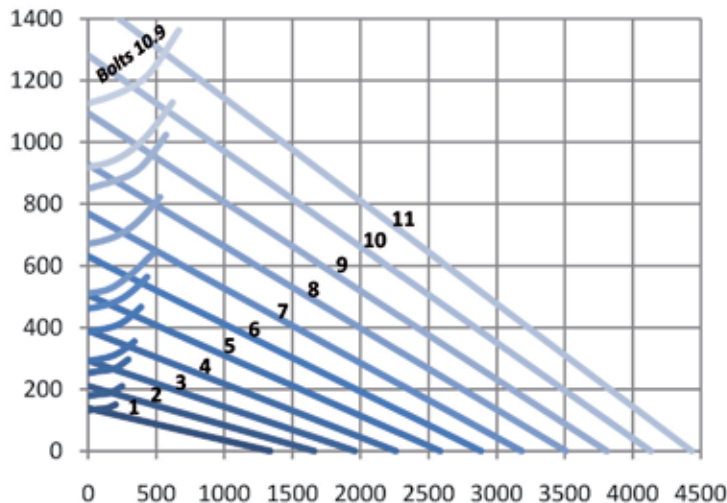
Please read technical instruction part 2 for correct use of load graph.

NB1.25 P

SERIE DE PRECISIÓN

PRECISION SERIES

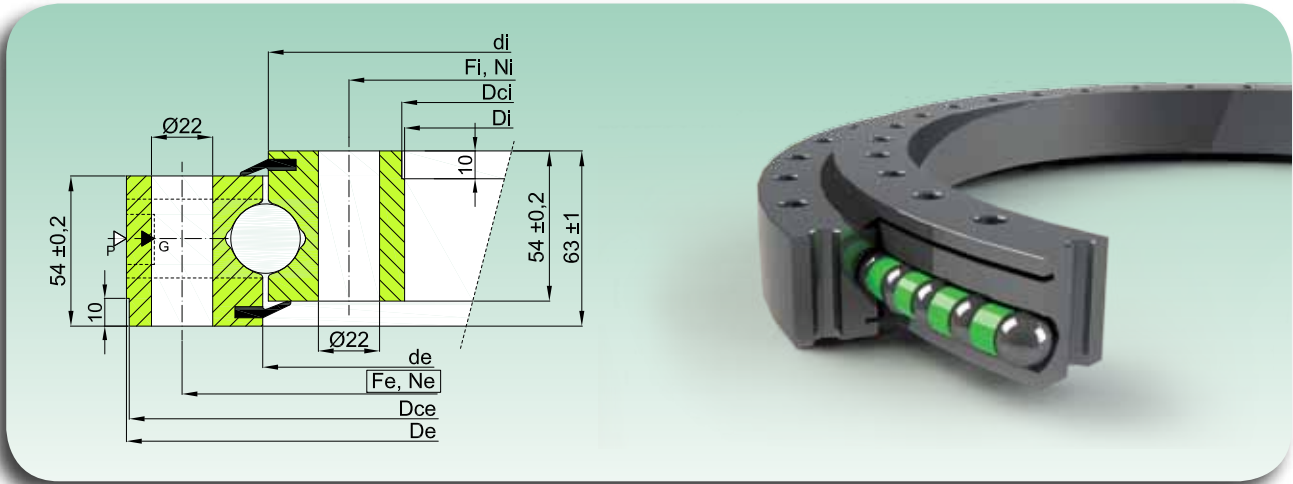

Código Code	Curva Curve	Dimensiones Dimensions						Orificios de fijación Fixing Holes				Juego ax. y radial Axial and Radial Clearance	Peso Weight
		De [mm]	Dce [mm]	de [mm]	di [mm]	Dci [mm]	Di [mm]	Fe [mm]	Ne [-]	Fi [mm]	Ni [-]		
NB1.25.0455.201-2PPN	1	555	553 -0,11	454	456	357 +0,09	355	515	18	395	18	0 ÷ 0,03	53
NB1.25.0555.201-2PPN	2	655	653 -0,13	554	556	457 +0,10	455	615	20	495	20	0 ÷ 0,03	65
NB1.25.0655.201-2PPN	3	755	753 -0,14	654	656	557 +0,11	555	715	24	595	24	0 ÷ 0,03	76
NB1.25.0755.201-2PPN	4	855	853 -0,14	754	756	657 +0,13	655	815	24	695	24	0 ÷ 0,04	90
NB1.25.0855.201-2PPN	5	955	953 -0,14	854	856	757 +0,14	755	915	28	795	28	0 ÷ 0,04	101
NB1.25.0955.201-2PPN	6	1055	1053 -0,14	954	956	857 +0,14	855	1015	30	895	30	0 ÷ 0,05	115
NB1.25.1055.201-2PPN	7	1155	1153 -0,17	1054	1056	957 +0,14	955	1115	30	995	30	0 ÷ 0,05	128
NB1.25.1155.201-2PPN	8	1255	1253 -0,17	1154	1156	1057 +0,17	1055	1215	36	1095	36	0 ÷ 0,06	139
NB1.25.1255.201-2PPN	9	1355	1353 -0,17	1254	1256	1157 +0,17	1155	1315	42	1195	42	0 ÷ 0,07	150
NB1.25.1355.201-2PPN	10	1455	1453 -0,20	1354	1356	1257 +0,17	1255	1415	42	1295	42	0 ÷ 0,07	163
NB1.25.1455.201-2PPN	11	1555	1553 -0,20	1454	1456	1357 +0,20	1355	1515	48	1395	48	0 ÷ 0,07	174

- Material: C45Q+T

- Material C45 Q+T

- Llenos de grasa, protegidos por aceite y envueltos en resistente película plástica

- Full of grease, protected by oil and wrapped in resistant plastic film

▷ P=tapón inserción bolas / filling plug

▶ G=n.4/6 engrasadores M10X1 / n.4/6greasers M10X1

Mf
Momento de inclinación equivalente [KNm]
Equivalent Tilting moment [KNm]

Leer las instrucciones técnicas - parte 2 - para la utilización correcta del gráfico

Please read technical instruction part 2 for correct use of load graph.



DIAGRAMA DE CARGA ESTÁTICA PARA ESFUERZOS DE COMPRESIÓN

STATIC LOAD CHARTS VALID FOR COMPRESSIVE LOADS

Fa

Carga axial equivalente [KN]
Equivalent axial load [KN]

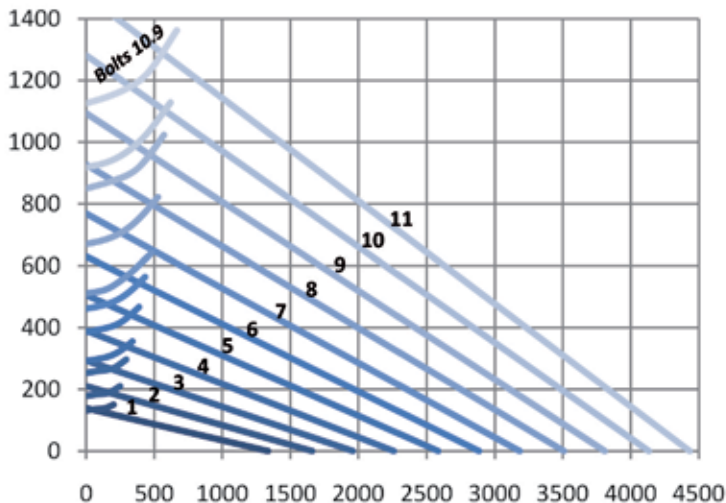
NB1.25 R

SERIE ESTÁNDAR STANDARD SERIES

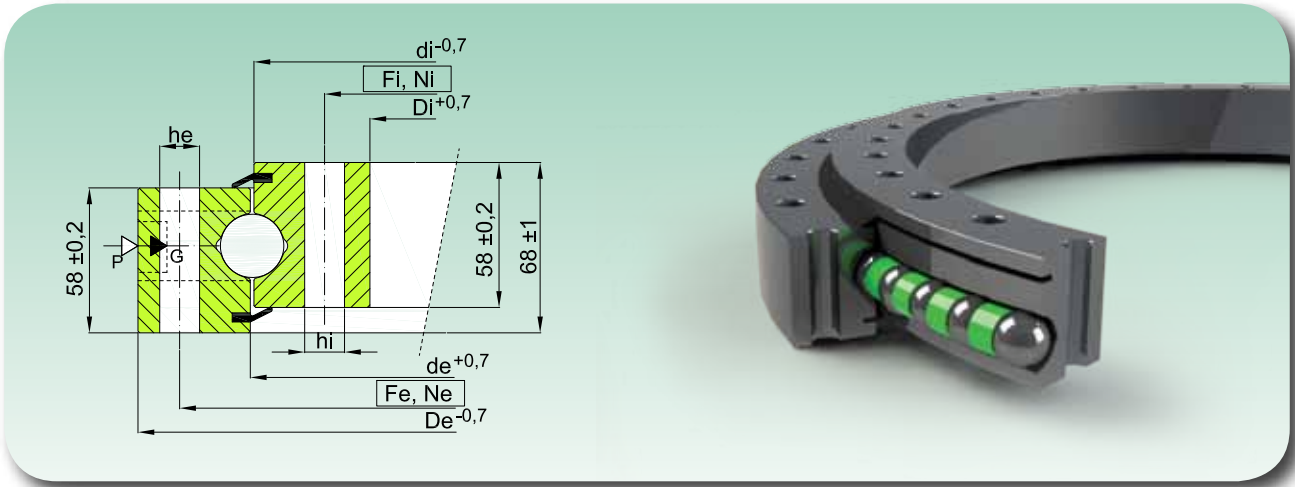

Código Code	Curva Curve	Dimensiones Dimensions				Orificios de fijación Fixing Holes						Peso Weight [kg]
		De [mm]	de [mm]	di [mm]	Di [mm]	Fe [mm]	Ne [-]	he [mm]	Fi [mm]	Ni [-]	hi [mm]	
NB1.25.1204.400-1PPN	1	1289	1206	1202	1119	1257	45	16	1151	45	16	121
NB1.25.1314.400-1PPN	2	1399	1316	1312	1229	1367	50	16	1261	50	16	132
NB1.25.1424.400-1PPN	3	1509	1426	1422	1339	1477	54	16	1371	54	16	143
NB1.25.1534.400-1PPN	4	1619	1536	1532	1449	1587	60	16	1481	60	16	154
NB1.25.1644.400-1PPN	5	1752	1646	1642	1536	1708	54	22	1580	54	22	209
NB1.25.1754.400-1PPN	6	1862	1756	1752	1646	1818	60	22	1690	60	22	222
NB1.25.1904.400-1PPN	7	2012	1906	1902	1796	1968	64	22	1840	64	22	241

- Material: 42CrMo4 Q+T
 - Juego axial máx. 0,40 mm - Juego radial máx. 0,30 mm
 - Llenos de grasa, protegidos por aceite y envueltos en resistente película plástica
 ▷ P=tapón inserción bolas / filling plug ▶ G= n.6 engrasadores M8X1 / n.6 greasers M8X1.

- Material 42CrMo4 Q+T
 - Axial clearance max. 0,40 mm - Radial clearance max. 0,30 mm
 - Full of grease, protected by oil and wrapped in resistant plastic film

Mf
Momento de inclinación equivalente [KNm]
Equivalent Tilting moment [KNm]



DIAGRAMA DE CARGA ESTÁTICA PARA ESFUERZOS DE COMPRESIÓN

STATIC LOAD CHARTS VALID FOR COMPRESSIVE LOADS

Fa
Carga axial equivalente [KN]
Equivalent axial load [KN]

Leer las instrucciones técnicas - parte 2 - para la utilización correcta del gráfico

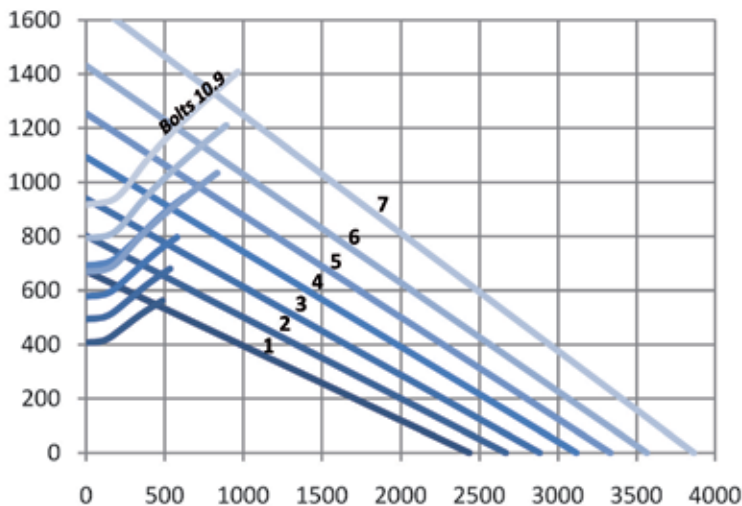
Please read technical instruction part 2 for correct use of load graph.

NB1 STOCK

SERIE ESTÁNDAR

STANDARD SERIES

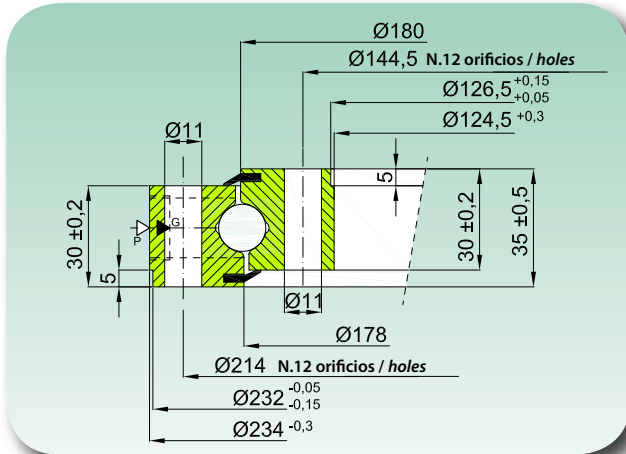
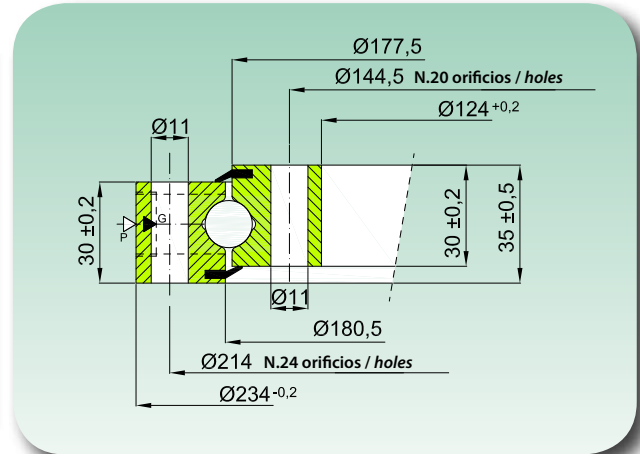
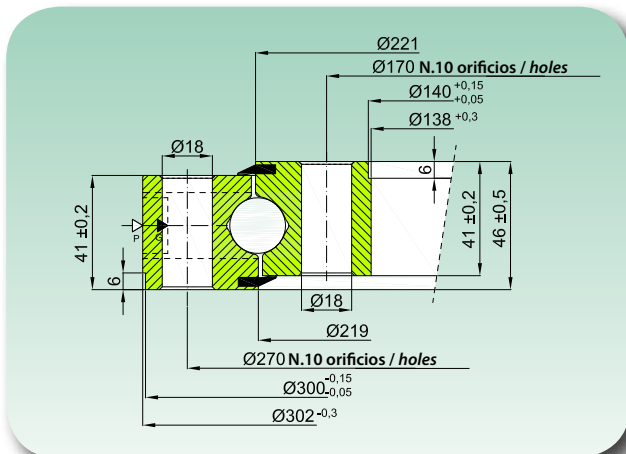
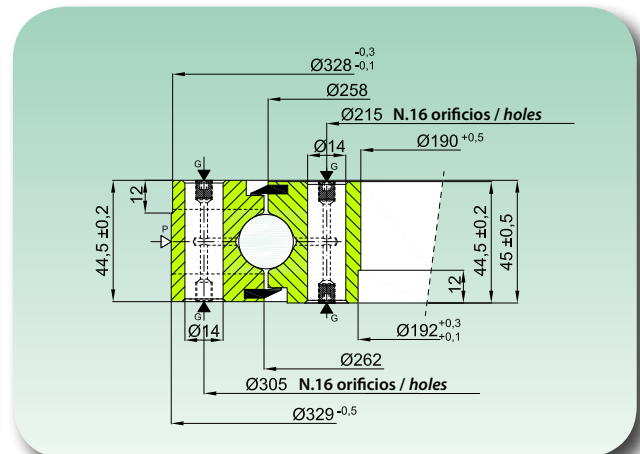
NB1.14.0179.200-1PPN

NB1.14.0179.201-1PPN

NB1.20.0220.200-1PPN

NB1.20.0260.200-1PPN

Código Code	Curva Curve	Material Material	Peso Weight
			[Kg]
NB1.14.0179.200-1PPN	1-a	C45 Q+T	7
NB1.14.0179.201-1PPN	1-b	C45 Q+T	7
NB1.20.0220.200-1PPN	2	C45 Q+T	16
NB1.20.0260.200-1PPN	3	C45 Q+T	18



DIAGRAMA DE CARGA ESTÁTICA PARA ESFUERZOS DE COMPRESIÓN
 STATIC LOAD CHARTS VALID FOR COMPRESSIVE LOADS

Leer las instrucciones técnicas - parte 2 - para la utilización correcta del gráfico
 Please read technical instruction - part 2 - for correct use of load graph.

NB1 STOCK

SERIE ESTÁNDAR

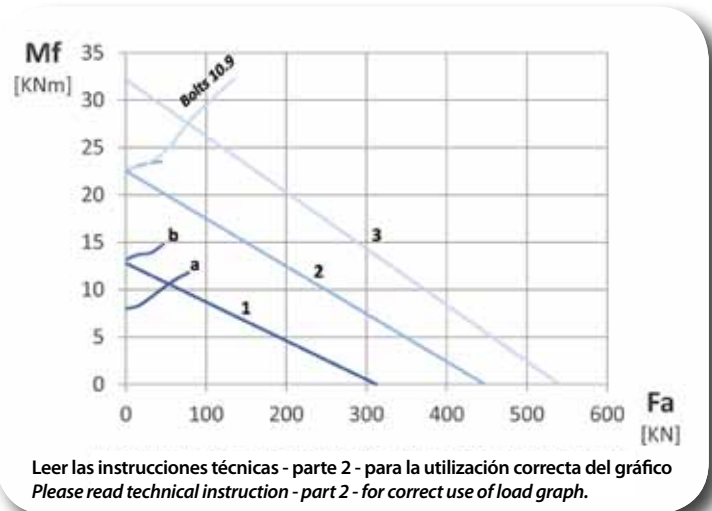
STANDARD SERIES

NB1.20.0260.201-1PPN

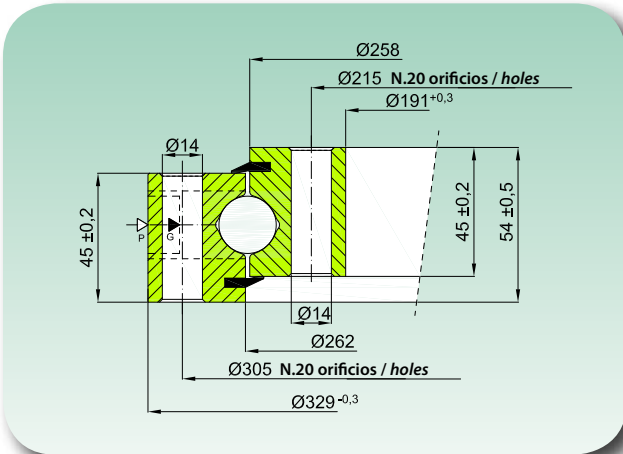

NB1.20.0260.202-1PPN

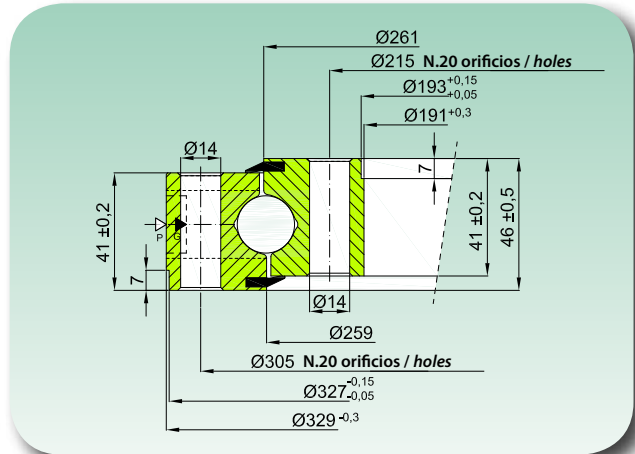

NB1.22.0308.200-1PPN

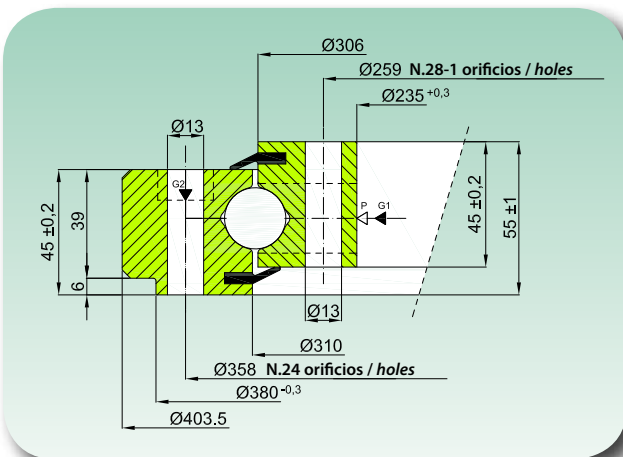

NB1.25.0308.200-1PPN

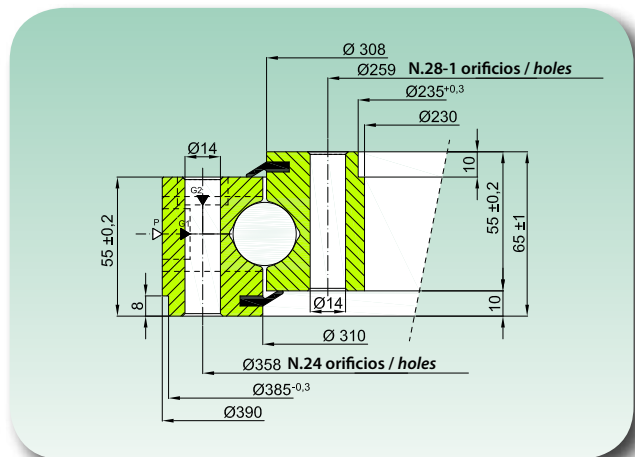

Código Code	Curva Curve	Material Material	Peso Weight
			[Kg]
NB1.20.0260.201-1PPN	4	C45 Q+T	16
NB1.20.0260.202-1PPN	4	C45 Q+T	15
NB1.22.0308.200-1PPN	5-a	C45 Q+T	25
NB1.25.0308.200-1PPN	6-a	C45 Q+T	28



DIAGRAMA DE CARGA ESTÁTICA PARA ESFUERZOS DE COMPRESIÓN
 STATIC LOAD CHARTS VALID FOR COMPRESSIVE LOADS

Leer las instrucciones técnicas - parte 2 - para la utilización correcta del gráfico
 Please read technical instruction - part 2 - for correct use of load graph.

NB1 STOCK
SERIE ESTÁNDAR

STANDARD SERIES

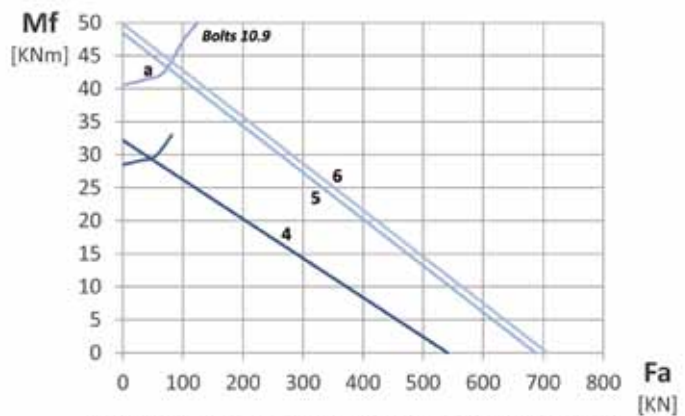
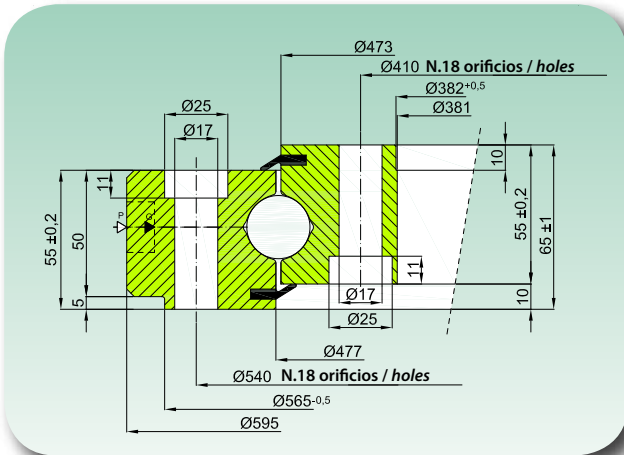
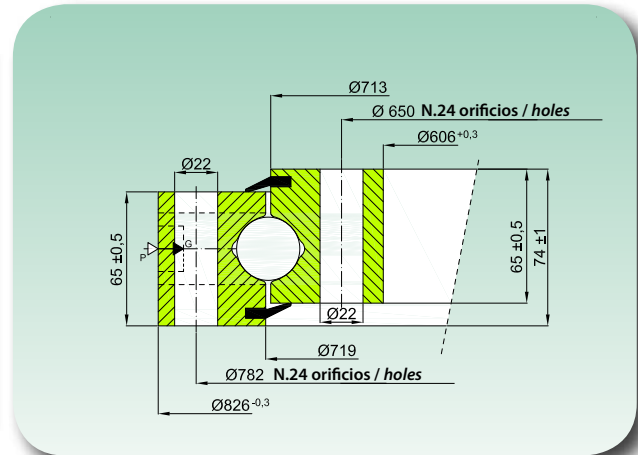
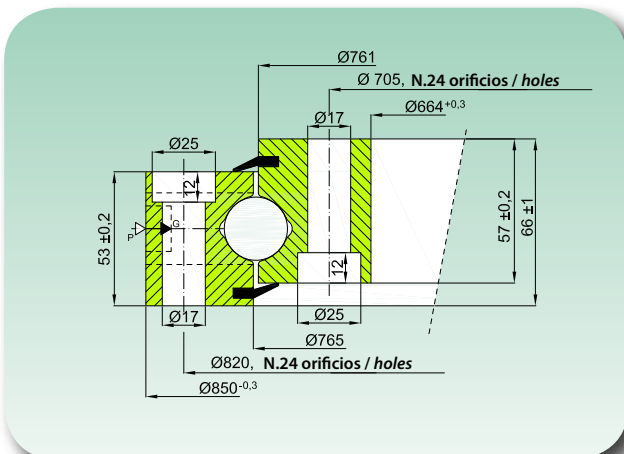
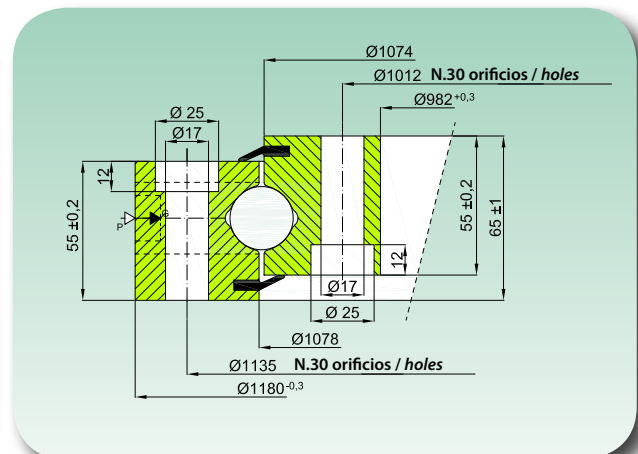
NB1.25.0475.200-1PPN

NB1.28.0716.200-1PPN

NB1.25.0763.200-1PPN

NB1.25.1076.200-1PPN

Código Code	Curva Curve	Material Material	Peso Weight
			[Kg]
NB1.25.0475.200-1PPN	7	C45 Q+T	62
NB1.28.0716.200-1PPN	8	C45 Q+T	80
NB1.25.0763.200-1PPN	9	C45 Q+T	116
NB1.25.1076.200-1PPN	10	C45 Q+T	120



DIAGRAMA DE CARGA ESTÁTICA PARA ESFUERZOS DE COMPRESIÓN
 STATIC LOAD CHARTS VALID FOR COMPRESSIVE LOADS

Leer las instrucciones técnicas - parte 2 - para la utilización correcta del gráfico
 Please read technical instruction - part 2 - for correct use of load graph.



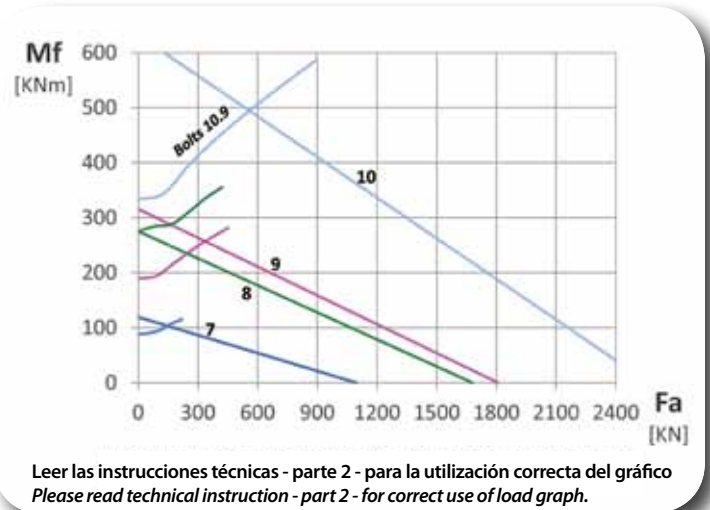

Coronas giratorias de dos giros de bolas, dentado exterior

Double row ball bearing, external toothed

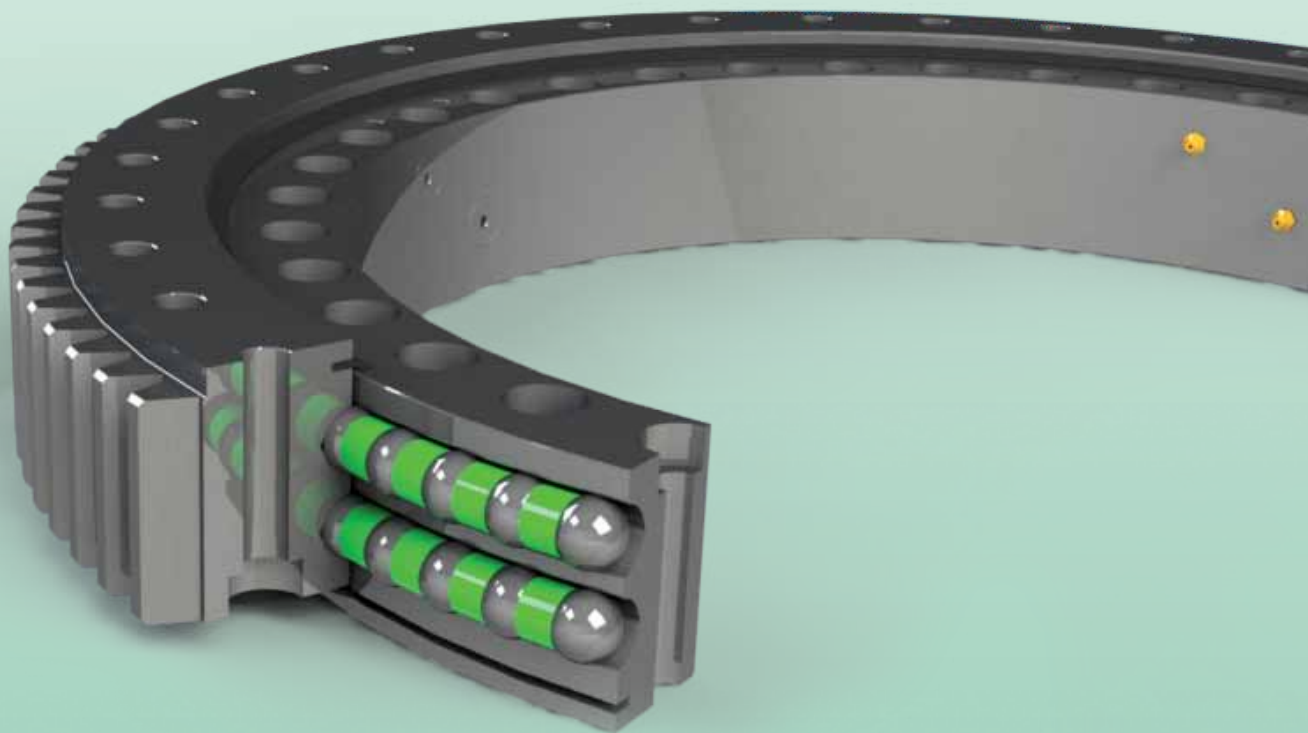

EB2 SERIES

EB2

SERIE ESTÁNDAR

STANDARD SERIES

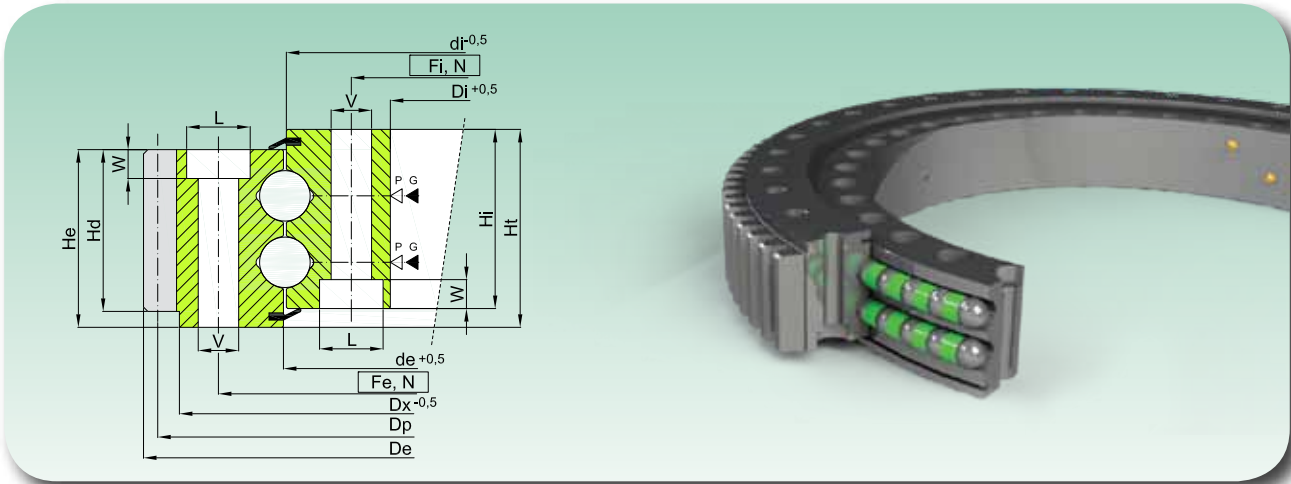

Código Code	Curva Curve	Dimensiones Dimensions									Orificios de fijación Fixing Holes						Dentado Gear data					Peso Weight [kg]	
		De [mm]	de [mm]	di [mm]	Di [mm]	Dx [mm]	He [mm]	Hi [mm]	Ht [mm]	Hd [mm]	Fe [mm]	Fi [-]	N	V [mm]	L [-]	W [mm]	m [mm]	Z [-]	xm [mm]	Dp [mm]	fz norm [kN]		fz max [kN]
EB2.22.0307.200-1SPPN	1	432	309	305	224	394	83	83	92	50	360	254	16	17	25	12	6	70	-	420	20,4	40,8	51
EB2.22.0383.200-1SPPN	2	504	385	381	300	466	83	83	92	75	436	330	16	17	25	12	8	61	-	488	40,8	81,6	64
EB2.25.0475.200-1SPPN	3	595	477	473	382	565	88	88	98	50	540	410	24	17	25	14	5	117	-	585	17	34	85
EB2.25.0575.200-1SPPN	4	712	577	573	470	670	88	88	98	75	640	508	24	17	25	9	8	87	-	696	40,8	81,6	123
EB2.20.0752.200-1SPPN	5	864	754	750	678	833	83	83	92	76	800	706	36	17	25	9	6	142	-	852	31,01	62,02	114
EB2.25.0821.200-1SPPN	6	979	823	819	718	935	92	92	102	86	893	753	36	21	31	15	10	94	+11	940	70,63	141,26	200
EB2.20.0968.200-1SPPN	7	1080	970	966	893	1042	83	83	92	76	1015	922	30	17	25	10	8	133	-	1064	41,34	82,69	148
EB2.25.1077.200-1SPPN	8	1200	1079	1075	976	1163	88	88	98	77	1135	1012	36	19	-	-	8	148	-	1184	41,89	83,78	210
EB2.28.1215.200-1SPPN	9	1380	1218	1212	1095	1330	98	98	108	90	1290	1135	48	23	34	16	10	136	-	1360	61,2	122,4	325

- Material: C45 Q+T

- Material C45 Q+T

- Posibilidad de dentado templado (-1RPPN)

- Induction gear hardening available on request (-1RPPN)

▷ P= tapón inserción bolas / filling plug

▶ G= n.2+2 engrasadores M8X1 / n.2+2 greasers M8X1

DIAGRAMA DE CARGA ESTÁTICA PARA ESFUERZOS DE COMPRESIÓN STATIC LOAD CHARTS VALID FOR COMPRESIVE LOADS

CURVAS / CURVES 1~6

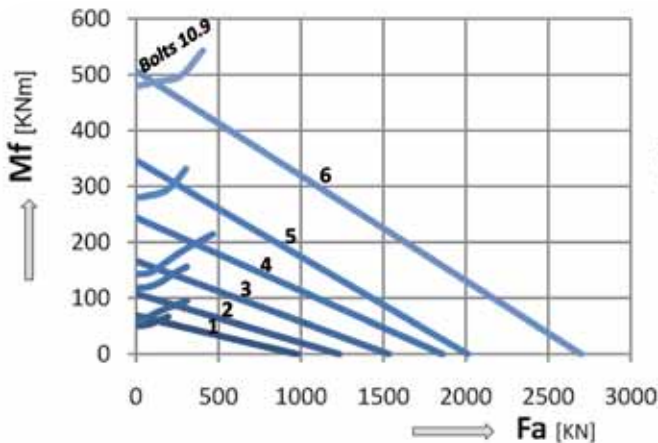

CURVAS / CURVES 7~9

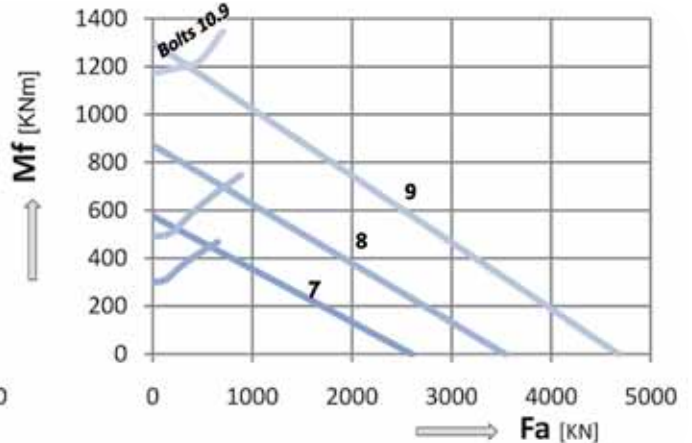

Leer las instrucciones técnicas - parte 2 - para la utilización correcta del gráfico - Please read technical instruction - part 2 - for correct use of load graph.

EB2

SERIE ESTÁNDAR

STANDARD SERIES

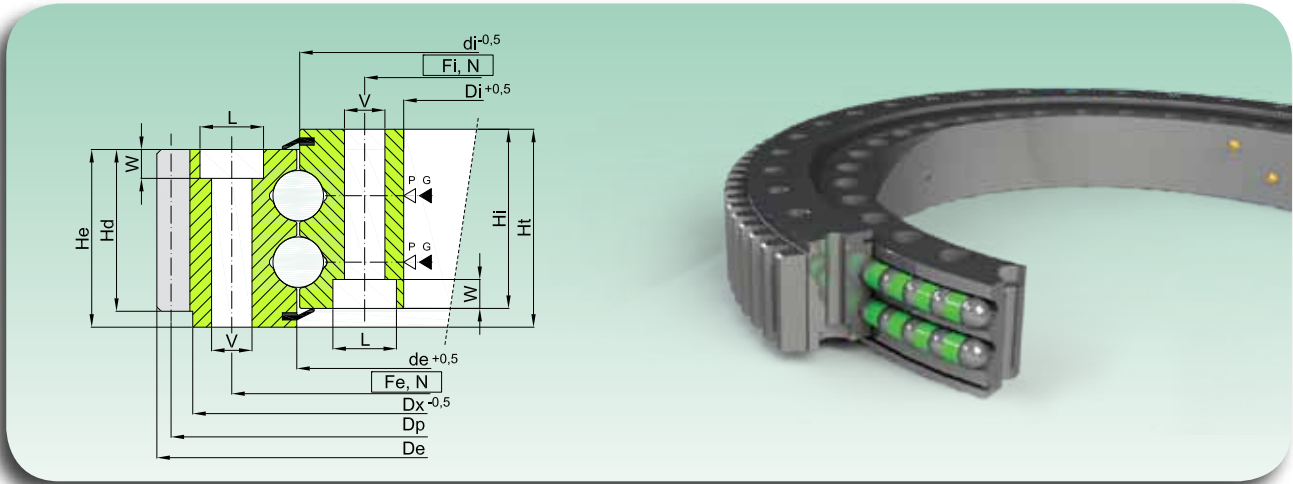

Código Code	Curva Curve	Dimensiones Dimensions								Orificios de fijación Fixing Holes						Dentado Gear data				Peso Weight [kg]			
		De [mm]	de [mm]	di [mm]	Di [mm]	Dx [mm]	He [mm]	Hi [mm]	Ht [mm]	Hd [mm]	Fe [mm]	Fi [-]	N	V [mm]	L [-]	W [mm]	m [mm]	Z [-]	xm [mm]		Dp [mm]	fz norm [kN]	fz max [kN]
EB2.22.0383.400-1SPPN	1	504	385	381	300	394	83	83	92	75	436	330	16	17	25	12	8	61	-	488	48	96	64
EB2.25.0475.400-1SPPN	2	614,4	477	473	378	565	88	88	98	80	540	410	24	19	28	14	8	74	+4	592	51,2	102,4	98
EB2.25.0575.400-1SPPN	3	695	577	573	470	670	83	83	92	58	640	508	30	17	25	13	5	136	+2,5	680	23,2	46,4	104
EB2.25.0980.400-1RPPN	4	1144	982	978	870	1096	96	96	110	88	1050	910	36	21	31	12	10	111	+8	1110	85,02	170,05	262
EB2.28.1117.400-1SPPN	5	1289	1120	1114	985	1240	98	98	108	83	1198	1035	40	21	31	18	10	125	+10,5	1250	80,19	160,39	332
EB2.28.1215.400-1SPPN	6	1380	1218	1212	1095	1330	98	98	108	90	1290	1135	36	23	34	16	10	136	-	1360	72	144	334
EB2.30.1249.400-1SPPN	7	1476	1252	1246	1085	1415	101	101	110	89	1350	1150	48	26	37	23	10	144	+8,6	1440	85,99	171,98	502

- Material: 42CrMo4 Q+T

- Llenos de grasa, protegidos por aceite y envueltos en resistente película plástica

- Posibilidad de dentado templado (-1RPPN)

▷ P=tapón inserción bolas / filling plug

▶ G=n.2+2 engrasadores M8X1 / n.2+2 greasers M8X1

- Material: 42CrMo4 Q+T

- Full of grease, protected by oil and wrapped in resistant plastic film

- Induction gear hardening available on request (-1RPPN)

DIAGRAMA DE CARGA ESTÁTICA PARA ESFUERZOS DE COMPRESIÓN STATIC LOAD CHARTS VALID FOR COMPRESSIVE LOADS

CURVAS / CURVES 1~3

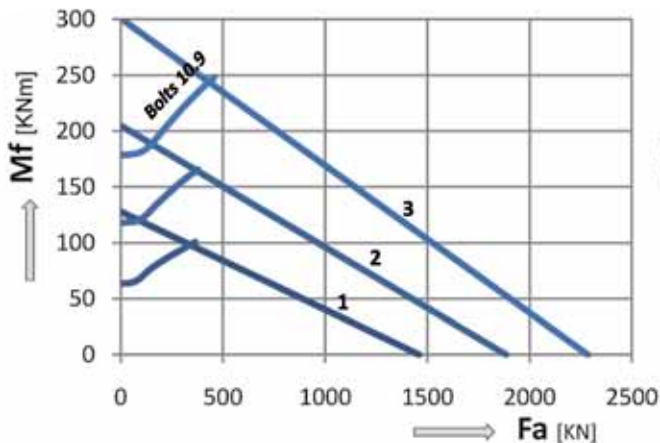

CURVAS / CURVES 4~7

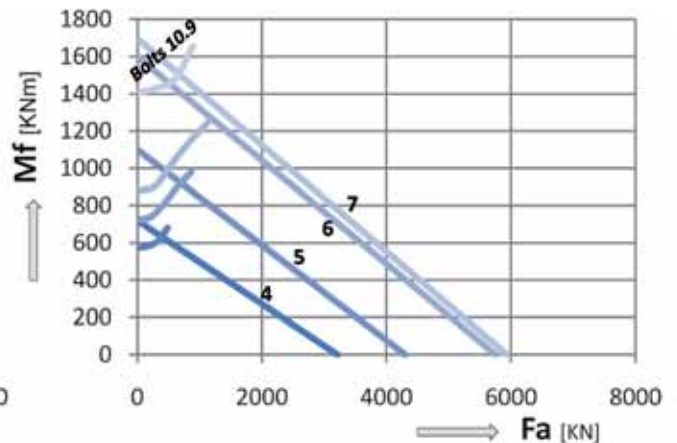

Leer las instrucciones técnicas - parte 2 - para la utilización correcta del gráfico - Please read technical instruction - part 2 - for correct use of load graph.

EB2

SERIE ESTÁNDAR

STANDARD SERIES

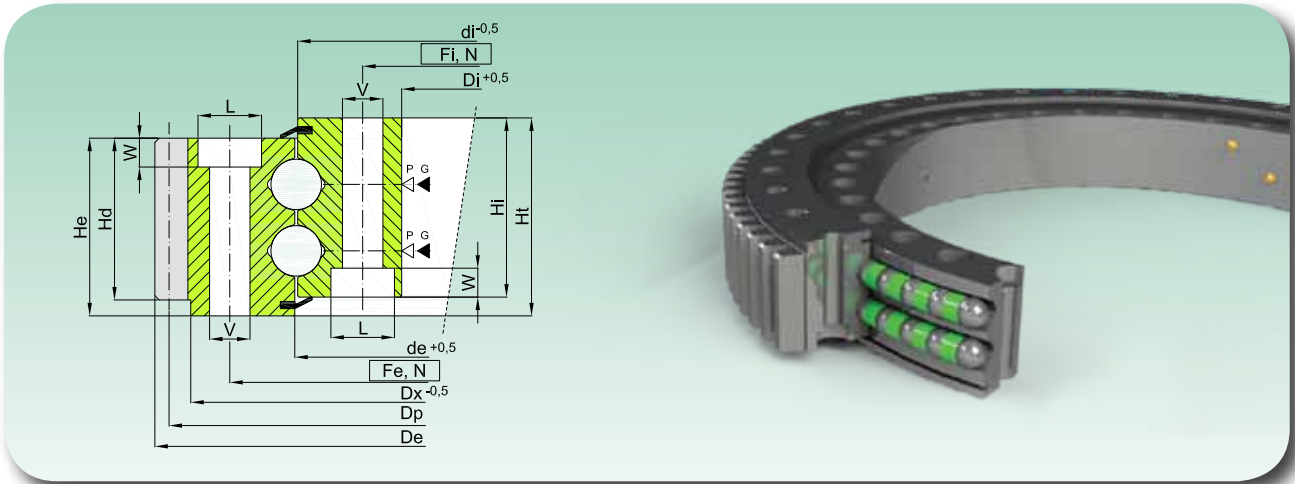

Código Code	Curva Curve	Dimensiones Dimensions								Orificios de fijación Fixing Holes						Dentado Gear data				Peso Weight [kg]			
		De [mm]	de [mm]	di [mm]	Di [mm]	Dx [mm]	He [mm]	Hi [mm]	Ht [mm]	Hd [mm]	Fe [mm]	Fi [-]	N [-]	V [mm]	L [mm]	W [mm]	m [mm]	Z [-]	xm [mm]		Dp [mm]	fz norm [kN]	fz max [kN]
EB2.35.1249.400-1SPPN	1	1472	1252	1246	1085	1406	134	134	144	115	1350	1150	36	28	41	27	14	102	+9,1	1428	147,78	295,56	640
EB2.30.1391.400-1SPPN	2	1603	1394	1388	1208	-	110	110	120	110	1500	1280	40	29	-	-	10	157	+7,5	1570	100,97	201,93	636
EB2.35.1402.401-1SPPN	3	1604	1405	1399	1208	1570	134	134	144	93	1500	1280	48	31	46	28	10	157	+7	1570	147,78	295,56	710
EB2.25.1391.400-1SPPN	4	1605	1394	1388	1208	1550	116	116	130	96	1494	1280	48	29	41	22	12	130	+12	1560	105,74	211,48	623
EB2.35.1390.400-1SPPN	5	1634	1393	1387	1208	-	138	134	148	138	1500	1280	48	31	46	24	14	113	+14	1582	177,33	354,67	800
EB2.30.1578.400-1SPPN	6	1808	1581	1575	1404	-	110	110	120	110	1680	1476	40	29	-	-	10	178	+5	1780	100,97	201,93	754
EB2.35.1578.400-1SPPN	7	1805	1581	1575	1433	-	140	140	156	140	1671	1485	60	28	41	15	16	109	+16,9	1744	205,6	411,21	810

- Material: 42CrMo4 Q+T

- Llenos de grasa, protegidos por aceite y envueltos en resistente película plástica

- Posibilidad de dentado templado (-1RPPN)

▷ P=tapón inserción bolas / filling plug

▶ G= n.2+2 engrasadores M8X1 / n.2+2 greasers M8X1

- Material: 42CrMo4 Q+T

- Full of grease, protected by oil and wrapped in resistant plastic film

- Induction gear hardening available on request (-1RPPN)

DIAGRAMA DE CARGA ESTÁTICA PARA ESFUERZOS DE COMPRESIÓN STATIC LOAD CHARTS VALID FOR COMPRESSIVE LOADS

CURVAS / CURVES 1,3,6,7

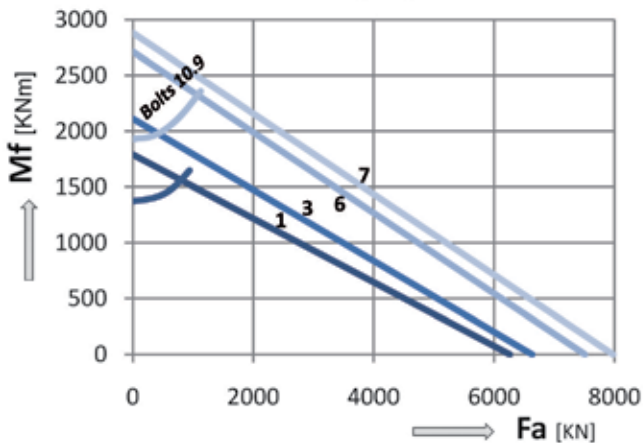

CURVAS / CURVES 2,4,5

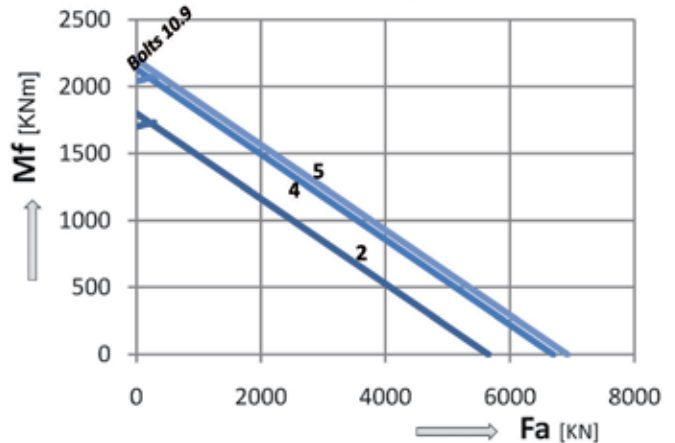

Leer las instrucciones técnicas - parte 2 - para la utilización correcta del gráfico - Please read technical instruction - part 2 - for correct use of load graph.



Coronas giratorias de dos giros de bolas, dentado interior

Double row ball bearing, internal toothed

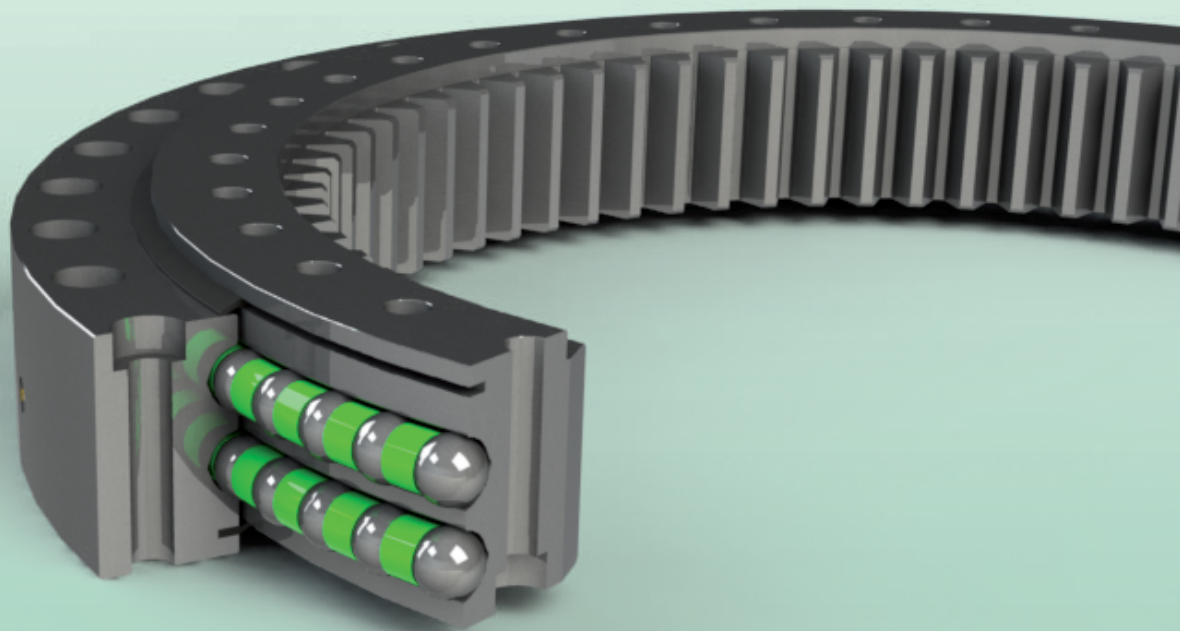

ZB2 SERIES

ZB2

SERIE ESTÁNDAR

STANDARD SERIES

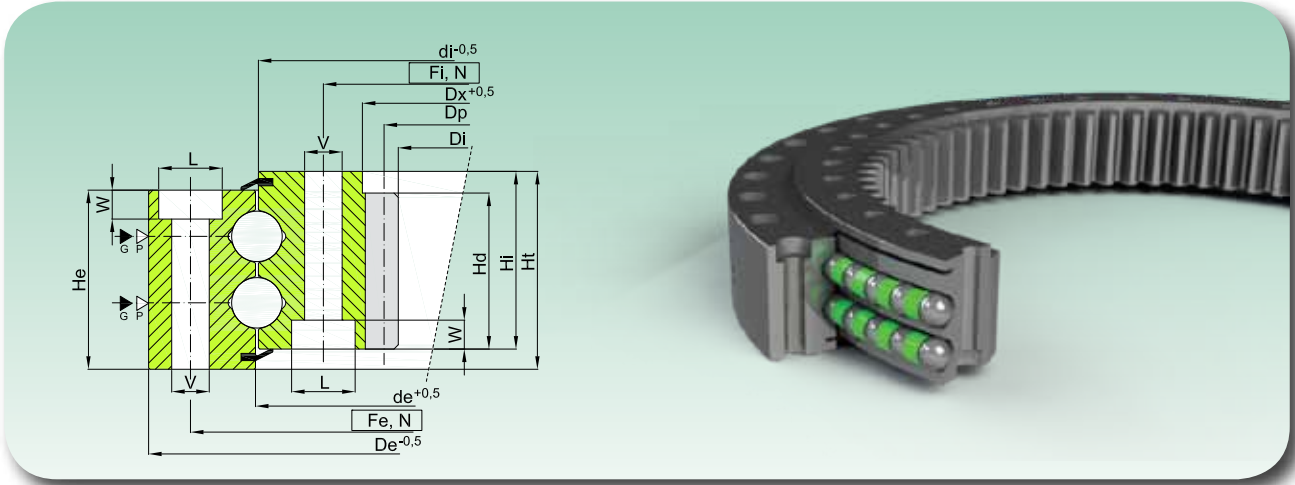

Código Code	Curva Curve	Dimensiones Dimensions									Orificios de fijación Fixing Holes						Dentado Gear data				Peso Weight [kg]		
		De	de	di	Di	Dx	He	Hi	Ht	Hd	Fe	Fi	N	V	L	W	m	Z	xm	Dp		fz norm	fz max
		[mm]	[mm]	[mm]	[mm]	[mm]	[mm]	[mm]	[mm]	[mm]	[mm]	[-]	[-]	[mm]	[-]	[-]	[mm]	[-]	[mm]	[mm]		[kN]	[kN]
ZB2.22.0625.400-1SPPN	1	705	627	623	504	547	83	83	92	74	675	575	32	17	25	9	8	65	-	520	49,33	98,67	95
ZB2.22.0763.400-1RPPN	2	850	765	761	641	-	83	83	92	83	820	705	36	17	25	17	8	81	-4	648	64,15	128,31	128
ZB2.20.0897.200-1SPPN	3	973	899	895	786	820	88	88	97	80	944	850	36	17	25	11	8	100	-	800	45,33	90,67	141
ZB2.22.0885.400-1SPPN	4	982	887	883	754	790	88	88	97	80	944	826	36	21	31	14	8	95	-4	760	61,84	123,67	170
ZB2.25.0972.400-1SPPN	5	1074	974	970	820	-	100	96	114	96	1035	910	40	21	-	-	10	84	-	840	76	152	234
ZB2.22.1088.200-1SPPN	6-a	1172	1090	1085	962	1010	88	88	97	80	1134	1040	36	17	25	11	10	98	-	980	56,67	113,33	193
ZB2.22.1088.201-1SPPN	6-b	1172	1090	1085	962	1010	88	88	97	80	1134	1040	48	17	25	11	10	98	-	980	56,67	113,33	189
ZB2.22.1088.400-1SPPN	6-a	1172	1090	1085	962	1010	88	88	97	80	1134	1040	36	17	25	11	10	97	-5	970	77,29	154,59	193
ZB2.25.1103.200-1SPPN	7	1200	1105	1099	963	1010	96	96	110	88	1160	1040	36	21	31	12	10	98	-	980	62,33	124,67	239

- Material: .400=42CrMo4 Q+T / .200=C45 Q+T

- Material: .400=42CrMo4 Q+T / .200=C45 Q+T

- Posibilidad de dentado templado (-1RPPN)

- Induction gear hardening available on request (-1RPPN)

▷ P=tapón inserción bolas / filling plug

▶ G= n.2+2 engrasadores M8X1 / n.2+2 greasers M8X1.

DIAGRAMA DE CARGA ESTÁTICA PARA ESFUERZOS DE COMPRESIÓN STATIC LOAD CHARTS VALID FOR COMPRESSIVE LOADS

CURVAS / CURVES 1~5

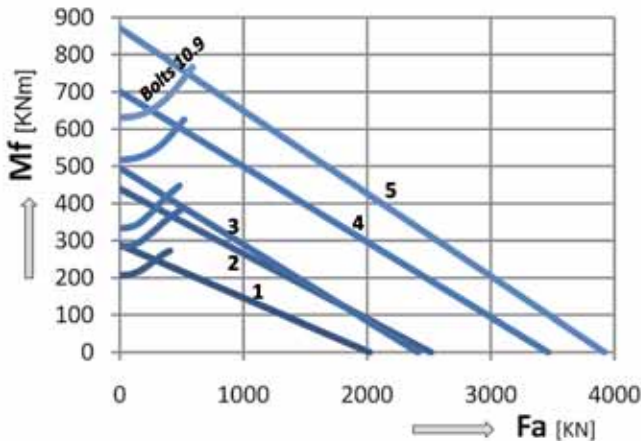

CURVAS Agujeros A o B / CURVES 6,7 (holes a or b)

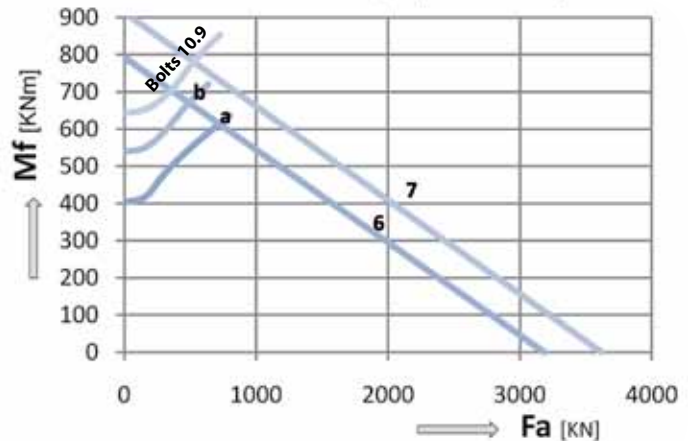

Leer las instrucciones técnicas - parte 2 - para la utilización correcta del gráfico - Please read technical instruction - part 2 - for correct use of load graph.

ZB2

SERIE ESTÁNDAR

STANDARD SERIES

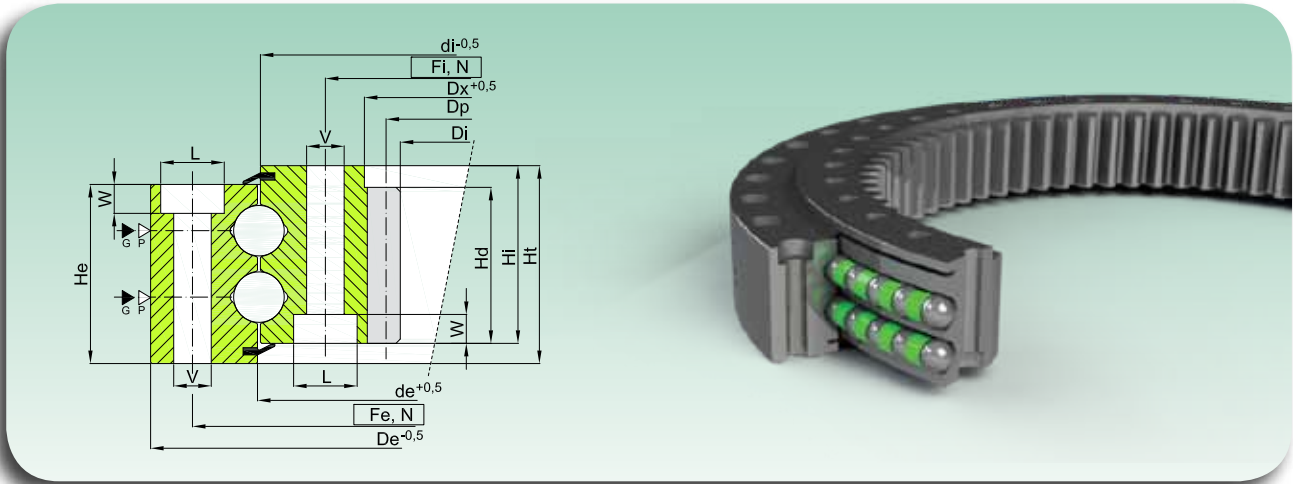

Código Code	Curva Curve	Dimensiones Dimensions								Orificios de fijación Fixing Holes						Dentado Gear data				Peso Weight [kg]			
		De	de	di	Di	Dx	He	Hi	Ht	Hd	Fe	Fi	N	V	L	W	m	Z	xm		Dp	fz norm	fz max
		[mm]	[mm]	[mm]	[mm]	[mm]	[mm]	[mm]	[mm]	[mm]	[mm]	[-]		[mm]	[-]	[mm]	[-]	[mm]	[mm]		[mm]	[kN]	[kN]
ZB2.25.1103.400-1SPPN	1-a	1200	1105	1099	963	1010	96	96	110	88	1160	1040	36	21	31	12	10	98	-	980	73,33	146,67	239
ZB2.25.1103.401-1SPPN	1-b	1200	1105	1099	963	1010	96	96	110	88	1160	1040	48	21	31	12	10	98	-	980	73,33	146,67	232
ZB2.30.1143.400-1SPPN	2	1250	1147	1141	998	-	99,5	99,5	110	99,5	1208	1080	36	21	31	12	10	100	-8	1000	91,33	182,66	276
ZB2.28.1222.400-1SPPN	3-a	1345	1225	1219	1061,6	1115	98	98	108	88	1290	1150	40	21	31	16	10	108	-	1080	73,33	146,67	331
ZB2.28.1222.401-1SPPN	3-b	1345	1225	1219	1061,6	1115	98	98	108	88	1290	1150	48	21	31	16	10	108	-	1080	73,33	146,67	326
ZB2.30.1351.400-1SPPN	4-a	1470	1354	1348	1183	1230	98	98	108	90	1425	1270	40	23	34	18	10	120	-	1200	71,25	142,5	371
ZB2.30.1351.401-1SPPN	4-a	1470	1354	1348	1176	1230	98	98	108	90	1425	1270	40	23	34	18	12	100	-	1200	85,5	171	371
ZB2.30.1351.402-1SPPN	4-b	1470	1354	1348	1176	1230	98	98	108	90	1425	1270	48	23	34	18	10	120	-	1200	71,25	142,5	365
ZB2.30.1351.403-1SPPN	4-b	1470	1354	1348	1176	1230	98	98	108	90	1425	1270	48	23	34	18	12	100	-	1200	85,5	171	365

- Material: 42CrMo4 Q+T

- Material: 42CrMo4 Q+T

- Posibilidad de dentado templado (-1RPPN)

- Induction gear hardening available on request (-1RPPN)

▷ P= tapón inserción bolas / filling plug

▷ G= n.2+2 engrasadores M8X1 / n.2+2 greasers M8X1.

DIAGRAMA DE CARGA ESTÁTICA PARA ESFUERZOS DE COMPRESIÓN STATIC LOAD CHARTS VALID FOR COMPRESSIVE LOADS

CURVAS Agujeros A o B / CURVES 1,4 (holes a or b)

CURVAS Agujeros A o B / CURVES 2,3 (holes a or b)

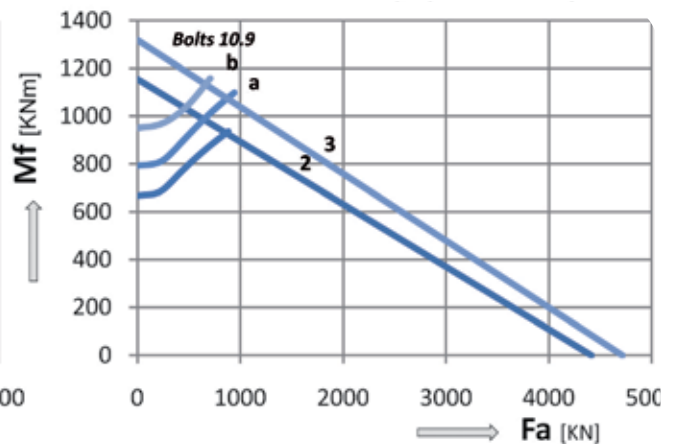
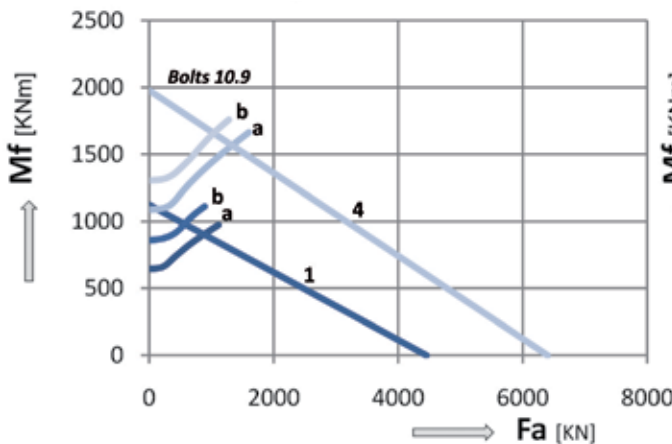

Leer las instrucciones técnicas - parte 2 - para la utilización correcta del gráfico - Please read technical instruction - part 2 - for correct use of load graph.

ZB2

SERIE ESTÁNDAR

STANDARD SERIES

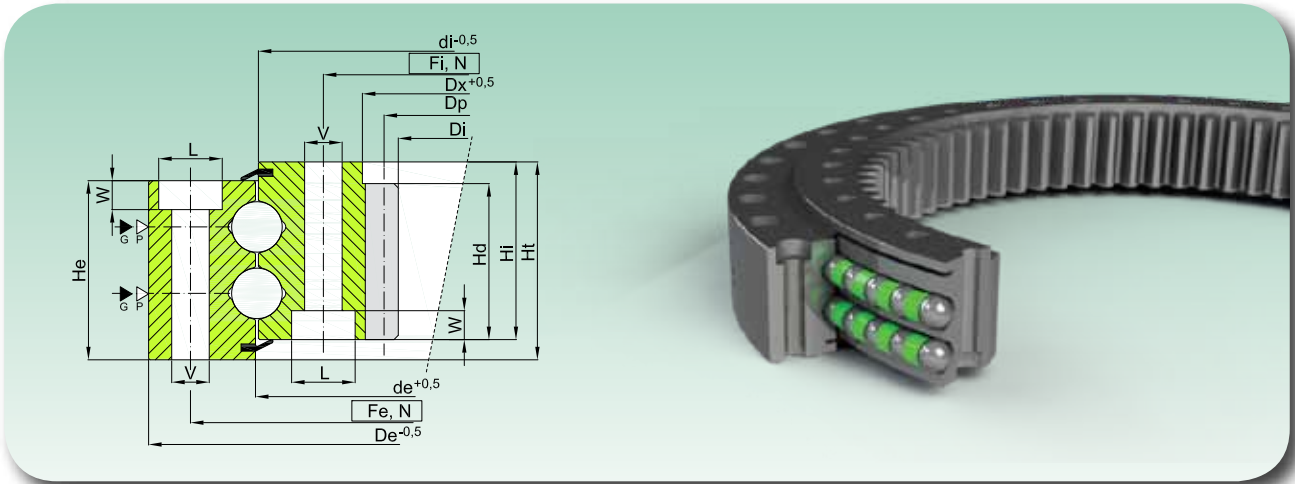

Código Code	Curva Curve	Dimensiones Dimensions								Orificios de fijación Fixing Holes						Dentado Gear data				Peso Weight [kg]			
		De [mm]	de [mm]	di [mm]	Di [mm]	Dx [mm]	He [mm]	Hi [mm]	Ht [mm]	Hd [mm]	Fe [mm]	Fi [-]	N	V [mm]	L [-]	W [mm]	m [mm]	Z [-]	xm [mm]		Dp [mm]	fz norm [kN]	fz max [kN]
ZB2.40.1386.400-1SPPN	1	1530	1389	1383	1186	1240	134	134	144	109	1480	1290	48	25	37	23	10	120	-3	1200	100	200	612
ZB2.40.1386.401-1SPPN	1	1530	1389	1383	1186	1240	134	134	144	119	1480	1290	48	25	37	23	12	100	-	1200	113	226	627
ZB2.30.1613.200-1SPPN	2	1750	1616	1610	1418,4	1470	110	105	120	98	1705	1525	40	25	37	23	12	120	-	1440	83,3	166,6	572
ZB2.30.1613.400-1SPPN	3	1750	1616	1610	1418,4	1470	110	105	120	98	1705	1525	48	25	37	23	12	120	-	1440	93,1	186,2	564
ZB2.45.1605.400-1SPPN	4	1780	1606	1602	1375	1438	134	134	144	124	1710	1500	48	31	46	28	14	100	-	1400	137,4	274,8	840
ZB2.45.1605.401-1SPPN	4	1780	1606	1602	1375	1382	134	134	144	124	1710	1500	48	31	46	28	12	117	-	1404	117,8	235,6	832
ZB2.35.1935.400-1SPPN	5	2100	1938	1932	1719	1774	134	134	144	120	2035	1835	72	29	-	-	12	145	-	1740	114	228	965
ZB2.35.2003.400-1SPPN	6	2178	2006	2000	1779	1835	134	134	144	120	2108	1898	72	29	-	-	12	150	-	1800	114	228	1062

- Material: 42CrMo4 Q+T
 - Posibilidad de dentado templado (-1RPPN)
 ▷ P= tapón inserción bolas / filling plug ▶ G= n.2+2 engrasadores M8X1 / n.2+2 greasers M8X1.

- Material: 42CrMo4 Q+T
 - Induction gear hardening available on request (-1RPPN)

DIAGRAMA DE CARGA ESTÁTICA PARA ESFUERZOS DE COMPRESIÓN
 STATIC LOAD CHARTS VALID FOR COMPRESSIVE LOADS

CURVAS / CURVES 1,4,5,6

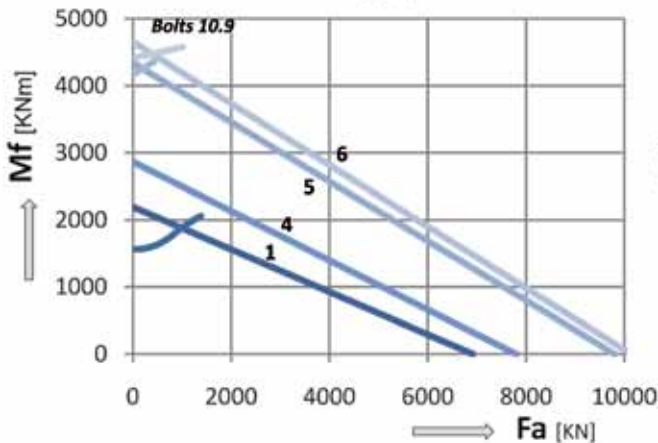

CURVAS / CURVES 2,3

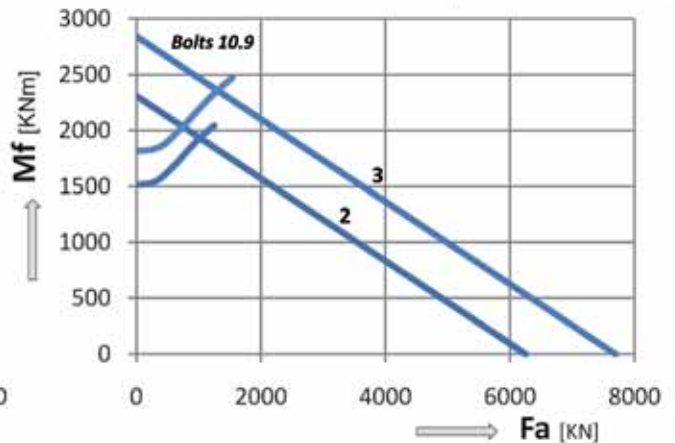

Leer las instrucciones técnicas - parte 2 - para la utilización correcta del gráfico - Please read technical instruction - part 2 - for correct use of load graph.



Coronas giratorias de una hilera de rodillos cruzados, dentado exterior

One row crossed roller bearing, external toothed

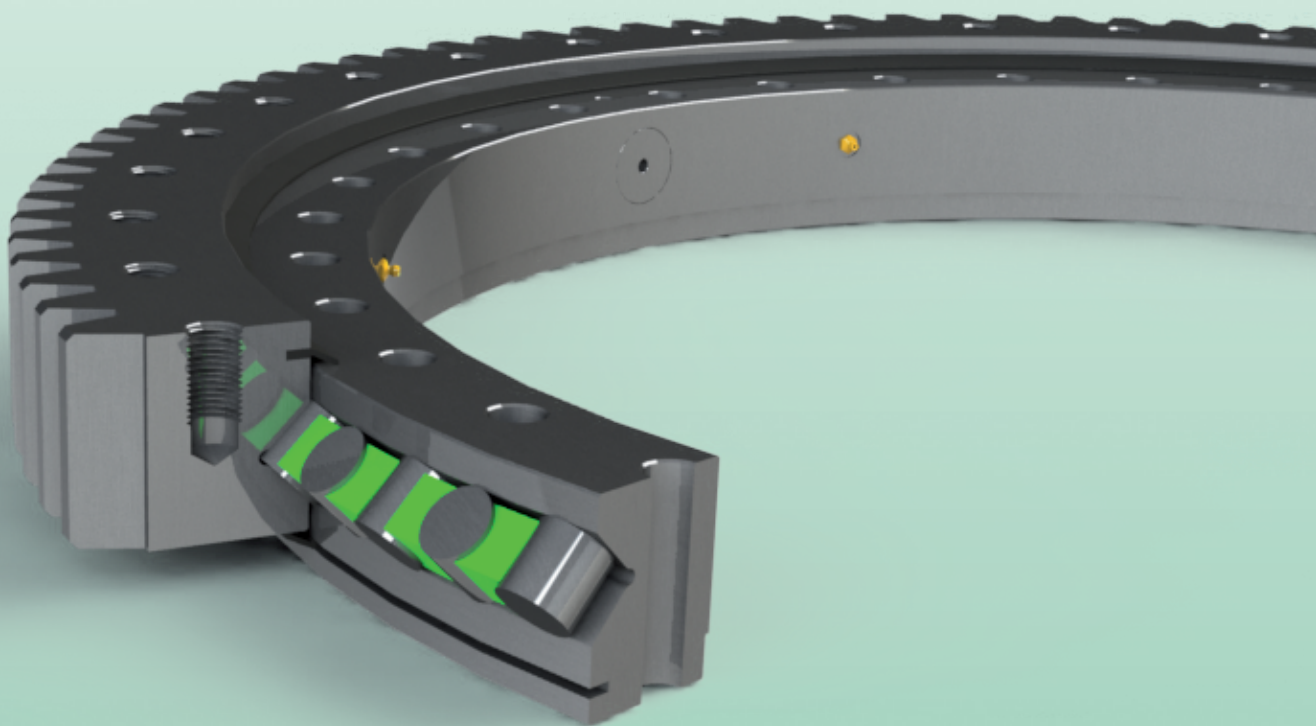

ER1 SERIES

ER1.14 S

SERIE ESTÁNDAR

STANDARD SERIES

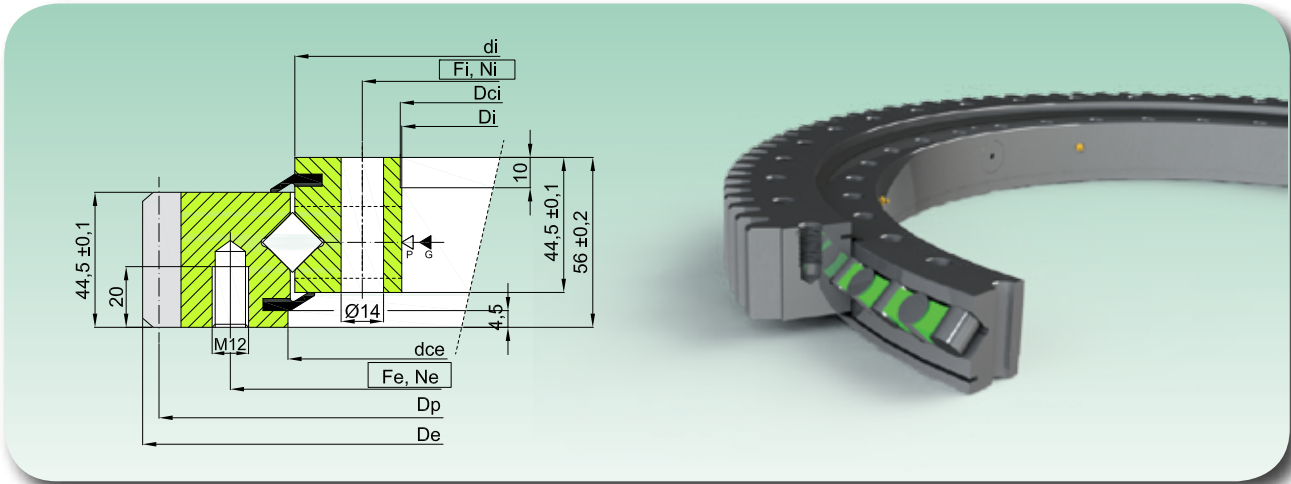

Código Code	Curva Curve	Dimensiones Dimensions					Orificios de fijación Fixing Holes				Dentado Gear data					Peso Weight [kg]
		De [mm]	dce +IT7 [mm]	di [mm]	Dci +IT7 [mm]	Di [mm]	Fe [mm]	Ne [-]	Fi [mm]	Ni	m [mm]	Z [-]	Dp [mm]	fz norm [kN]	fz max [kN]	
ER1.14.0414.200-1STPN	1	503,3	417	413-0,5	344	342	455	20	368	24	5	99	495	15,13	30,26	32
ER1.14.0544.200-1STPN	2	640,3	547	543-0,5	474	472	585	28	498	32	6	105	630	18,16	36,31	43
ER1.14.0644.200-1STPN	3	742,3	647	643-0,6	574	572	685	32	598	36	6	122	732	18,16	36,31	52
ER1.14.0744.200-1STPN	4	838,1	747	743-0,6	674	672	785	36	698	40	6	138	828	18,16	36,31	58
ER1.14.0844.200-1STPN	5	950,1	847	843-0,6	774	772	885	36	798	40	8	117	936	24,21	48,42	71
ER1.14.0944.200-1STPN	6	1046,1	947	943-0,7	874	872	985	40	898	44	8	129	1032	24,21	48,42	77
ER1.14.1094.200-1STPN	7	1198,1	1097	1093-0,7	1024	1022	1135	44	1048	48	8	148	1184	24,21	48,42	90

- Material: C45 Q+T
- Ensamblados con juego estrecho
- Llenos de grasa, protegidos por aceite y envueltos en resistente película plástica
- ▷ P=tapón inserción bolas / filling plug
- ▶ G= engrasadores M8X1 / greasers M8X1
- Material C45 Q+T
- Assembled with reduced clearances
- Full of grease, protected by oil and wrapped in resistant plastic film

Mf
Momento de inclinación equivalente [KNm]
Equivalent Tilting moment [KNm]



DIAGRAMA DE CARGA ESTÁTICA PARA ESFUERZOS DE COMPRESIÓN

STATIC LOAD CHARTS VALID FOR COMPRESSIVE LOADS

Fa
Carga axial equivalente [KN]
Equivalent axial load [KN]

Leer las instrucciones técnicas - parte 2 - para la utilización correcta del gráfico

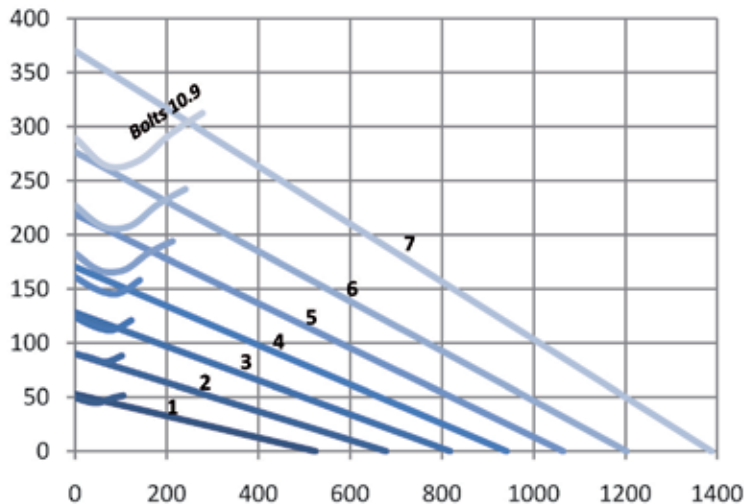
Please read technical instruction part 2 for correct use of load graph.

ER1.16 S

SERIE ESTÁNDAR

STANDARD SERIES

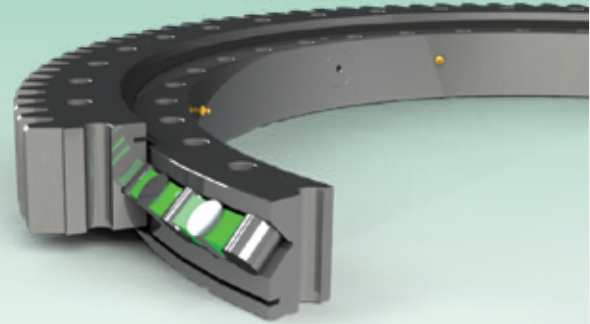
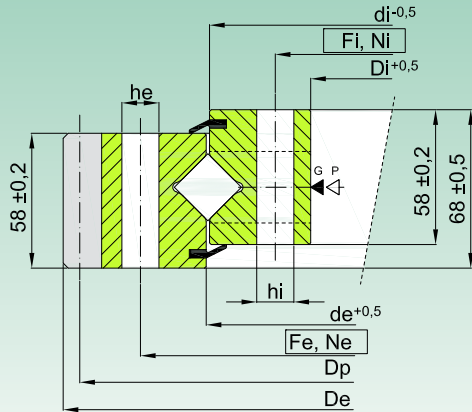

Código Code	Curva Curve	Dimensiones Dimensions				Orificios de fijación Fixing Holes						Dentado Gear data				Peso Weight [kg]	
		De [mm]	de [mm]	di [mm]	Di [mm]	Fe [mm]	Ne [-]	he [mm]	Fi [mm]	Ni [-]	hi [mm]	m [mm]	Z [-]	Dp [mm]	fz norm [kN]		fz max [kN]
ER1.16.1204.400-1SPPN	1	1338	1206	1202	1119	1257	45	16	1151	45	16	10	131	1310	46,4	92,8	154
ER1.16.1314.400-1SPPN	2	1448	1316	1312	1229	1367	50	16	1261	50	16	10	142	1420	46,4	92,8	168
ER1.16.1424.400-1SPPN	3	1558	1426	1422	1339	1477	54	16	1371	54	16	10	153	1530	46,4	92,8	182
ER1.16.1534.400-1SPPN	4	1668	1536	1532	1449	1587	60	16	1481	60	16	10	164	1640	46,4	92,8	195
ER1.16.1644.400-1SPPN	5	1791	1646	1642	1536	1708	54	22	1580	54	22	10	176	1760	46,4	92,8	242
ER1.16.1754.400-1SPPN	6	1901	1756	1752	1646	1818	60	22	1690	60	22	10	187	1870	46,4	92,8	258
ER1.20.1904.400-1SPPN	7	2073,4	1906	1902	1796	1968	64	22	1840	64	22	14	145	2030	64,96	129,92	306

- Material: 42CrMo4 Q+T

- Ensamblados con juego positivo

- Llenos de grasa, protegidos por aceite y envueltos en resistente película plástica

▷ P=tapón inserción bolas / filling plug

▶ G=engrasadores M8X1 / greasers M8X1

- Material 42CrMo4 Q+T

- Assembled with positive clearances

- Full of grease, protected by oil and wrapped in resistant plastic film

Mf

Momento de inclinación equivalente [KNm]
Equivalent Tilting moment [KNm]

Leer las instrucciones técnicas - parte 2 - para la utilización correcta del gráfico

Please read technical instruction part 2 for correct use of load graph.



DIAGRAMA DE CARGA ESTÁTICA PARA ESFUERZOS DE COMPRESIÓN

STATIC LOAD CHARTS VALID FOR COMPRESSIVE LOADS

Fa

Carga axial equivalente [KN]
Equivalent axial load [KN]

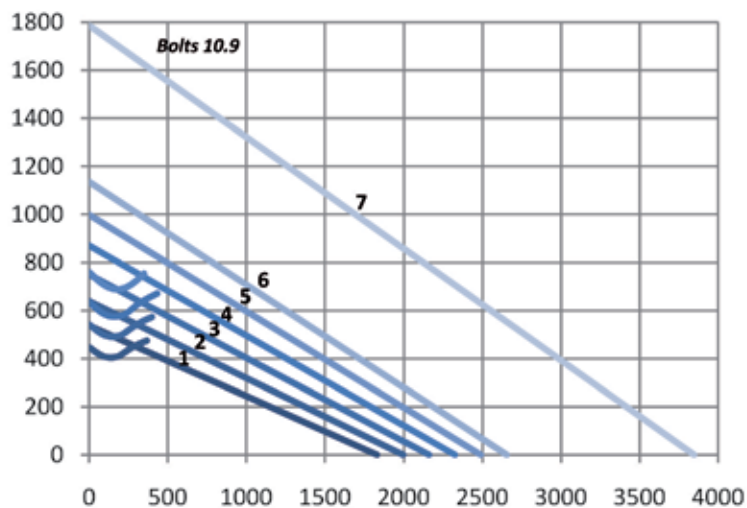
ER1.20/30

SERIE ESTÁNDAR

STANDARD SERIES

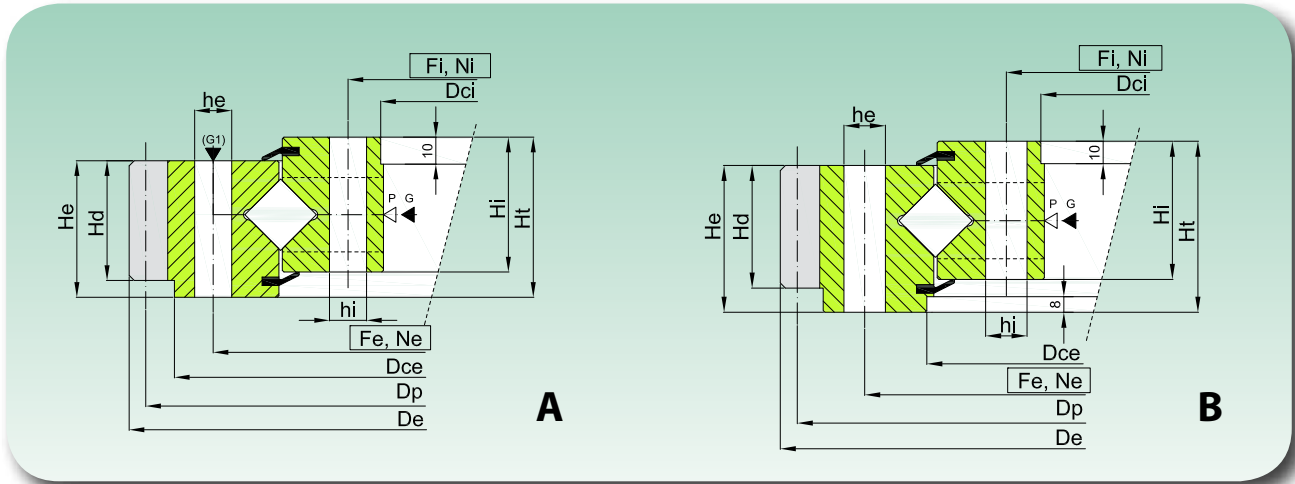

Código Code	Curva / Curve Forma / Shape	Dimensiones Dimensions							Orificios de fijación Fixing Holes					Dentado Gear data					Peso Weight [kg]	
		De [mm]	Dce [mm]	Dci [mm]	He [mm]	Hi [mm]	Ht [mm]	Hd [mm]	Fe [mm]	Ne [-]	he [mm]	Fi [mm]	Ni [-]	hl [-]	m [mm]	Z [-]	xm [mm]	Dp [mm]		fz norm [kN]
ER1.20.0307.400-1SPPN	1 B	403,5	312 +0,09	235 +0,09	47	45	55	42	358	24	13	259	28-1	13	4,5	88	-	396	15,12	24
ER1.25.0400.400-1SPPN	2 A	535	495 -0,10	306 +0,09	63	63	75	55	466	18	20	336	18	20	8	65	-	520	35,2	61
ER1.25.0475.400-1SPPN	3 A	589	565 -0,11	384 +0,09	63	63	75	55	540	18	20	410	18	20	5	116	-	580	22	63
ER1.30.0508.400-1SPPN	4 A	654	610 -0,13	392 +0,09	73	73	85	60	582	30	22	432	30-1	22	8	80	-	640	38,44	97
ER1.25.0574.400-1SPPN	5 A	700	670	480 +0,10	64	64	77	60	640	36	18	508	36-1	18	6	114	+3	690	34,78	82
ER1.25.0675.400-1SPPN	6 B	816	682 +0,13	574 +0,11	73	70	90	65	753	18	22	604	18	22	6	132	+6,552	805,1	37,68	124
ER1.25.0734.400-1SPPN	7 B	886	740 +0,14	615 +0,13	75	70	85	75	810	30	22	658	30	22	8	108	+4	872	57,97	155
ER1.30.0823.400-1SPPN	8 B	979	845 +0,14	718 +0,14	79	82	100	65	893	36	22	753	36-1	22	10	94	+11	962	62,8	178
ER1.30.0980.400-1SPPN	9 B	1144	993 +0,14	870 +0,14	79	84	100	67	1050	36	22	910	36	22	10	111	+8	1126	64,73	228

- Material: 42CrMo4 Q+T

- Ensamblados con juego estrecho / pre-carga bajo demanda

- Llenos de grasa, protegidos por aceite y envueltos en resistente película plástica

▷ P=tapón inserción bolas / filling plug

▶ G=engrasadores M8X1 / greasers M8X1

- Material 42CrMo4 Q+T

- Assembled with reduced clearances / preload on request

- Full of grease, protected by oil and wrapped in resistant plastic film

Mf
Momento de inclinación equivalente [KNm]
Equivalent Tilting moment [KNm]

Leer las instrucciones técnicas - parte 2 - para la utilización correcta del gráfico

Please read technical instruction part 2 for correct use of load graph.



DIAGRAMA DE CARGA ESTÁTICA PARA ESFUERZOS DE COMPRESIÓN

STATIC LOAD CHARTS VALID FOR COMPRESSIVE LOADS

Fa

Carga axial equivalente [KN]
Equivalent axial load [KN]

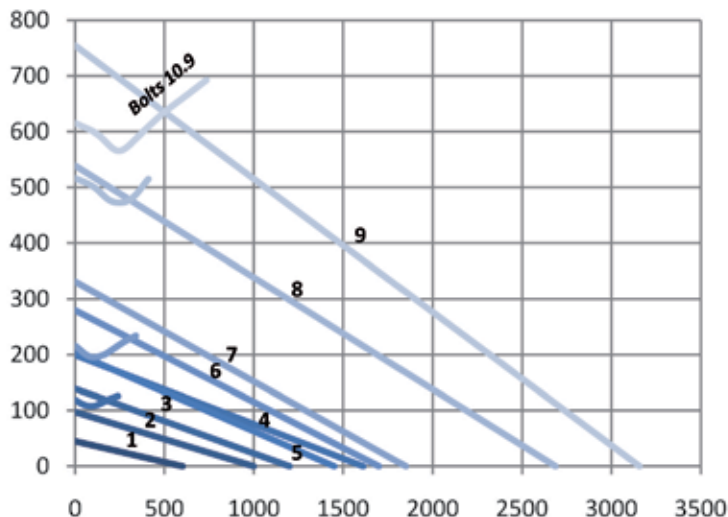
ER1.36/50

SERIE ESTÁNDAR

STANDARD SERIES

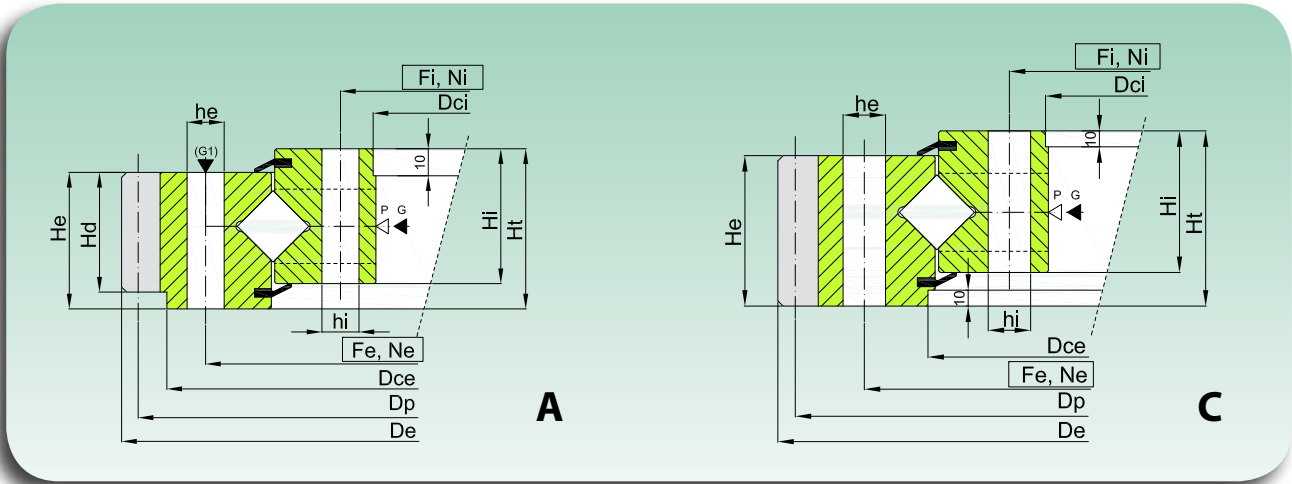

Código Code	Curva / Curve Forma / Shape	Dimensiones Dimensions							Orificios de fijación Fixing Holes					Dentado Gear data				Peso Weight [kg]		
		De	Dce	Dci	He	Hi	Ht	Hd	Fe	Ne	he	Fi	Ni	hl	m	Z	xm		Dp (xm)	fz norm
		[mm]	[mm]	[mm]	[mm]	[mm]	[mm]	[mm]	[mm]	[-]	[mm]	[mm]	[-]	[-]	[mm]	[-]	[mm]		[mm]	[kN]
ER1.36.1116.400-1SPPN	1 A	1289,5	1240 -0,17	985 +0,14	90	94	114	78	1198	40	22	1035	40	22	10	125	+10,5	1271	75,4	335
ER1.36.1250.400-1SPPN	2 A	1476	1415 -0,20	1080 +0,14	91	100	110	79	1350	40	26	1150	40	26	10	144	+8,6	1457,2	75,4	505
ER1.45.1390.400-1SPPN	3 A	1604	1551 -0,20	1205 +0,17	112	116	130	90	1500	48	30	1280	48	30	10	157	+7,5	1585	87	620
ER1.45.1595.400-1SPPN	4 C	1836	1608 +0,20	1437 +0,20	120	115	135	-	1700	45	30	1485	45	30	16	112	+8	1808	185,5	791
ER1.45.1790.400-1SPPN	5 C	2027	1808 +0,25	1617 +0,20	130	128	150	-	1905	48	30	1675	48	30	14	142	+7	2002	175,8	1004
ER1.50.2002.400-1SPPN	6 C	2267	2013 +0,30	1822 +0,25	129	119	140	-	2124	72	30	1880	72	30	16	139	+8	2240	199,4	1174
ER1.50.2242.400-1SPPN	7 C	2534	2260 +0,20	2049 +0,30	132	122	144	-	2373	60	33	2112	60	33	18	138	+9	2502	229,6	1482
ER1.50.2500.400-1SPPN	8 C	2790	2508 +0,30	2297 +0,30	148	142	164	-	2640	72	33	2360	72	33	18	151	+19,8	2757,6	257,4	1895
ER1.50.2810.400-1SPPN	9 C	3116	2818 +0,35	2607 +0,35	148	142	164	-	2950	80	33	2670	80	33	20	152	+20	3080	286	2200

- Material: 42CrMo4 Q+T

- Ensamblados con juego positivo

- Llenos de grasa, protegidos por aceite y envueltos en resistente película plástica

▷ P=tapón inserción bolas / filling plug

▶ G=engrasadores M8X1 / greasers M8X1

- Material 42CrMo4 Q+T

- Assembled with positive clearances

- Full of grease, protected by oil and wrapped in resistant plastic film

Mf
Momento de inclinación equivalente [KNm]
Equivalent Tilting moment [KNm]



DIAGRAMA DE CARGA ESTÁTICA PARA ESFUERZOS DE COMPRESIÓN

STATIC LOAD CHARTS VALID FOR COMPRESSIVE LOADS

Fa
Carga axial equivalente [KN]
Equivalent axial load [KN]

Leer las instrucciones técnicas - parte 2 - para la utilización correcta del gráfico

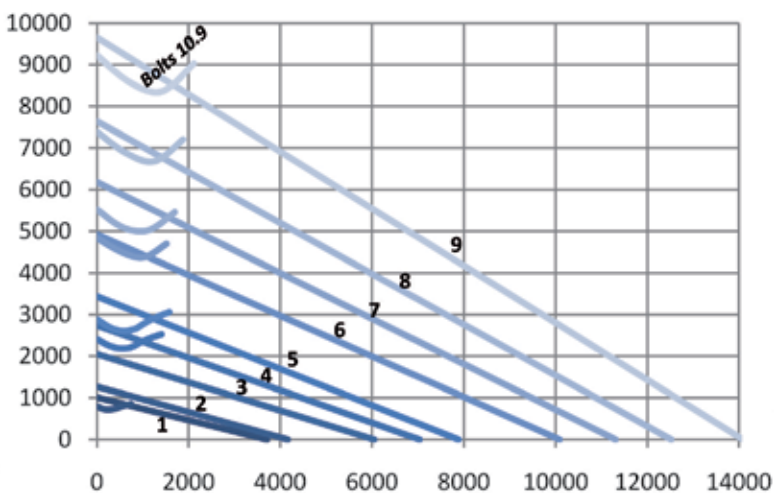
Please read technical instruction part 2 for correct use of load graph.



Coronas giratorias de una hilera de rodillos cruzados, dentado interior

One row crossed roller bearing, internal toothed

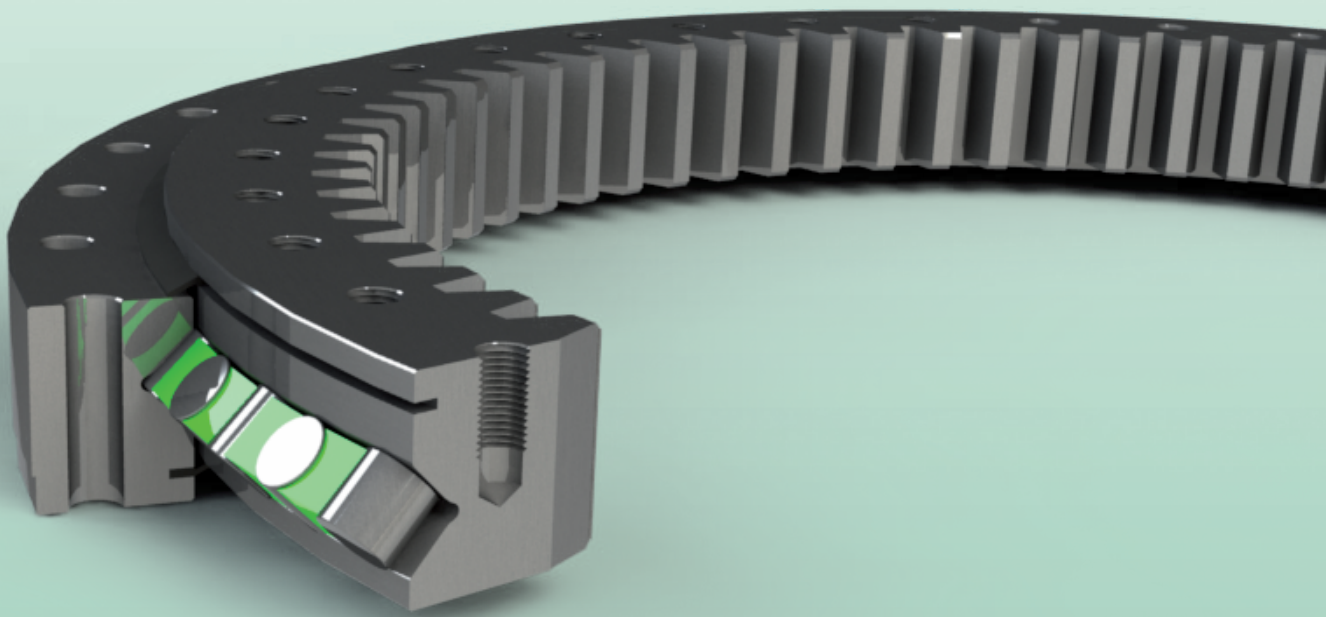

ZR1 SERIES

ZR1.14 S

SERIE ESTÁNDAR

STANDARD SERIES

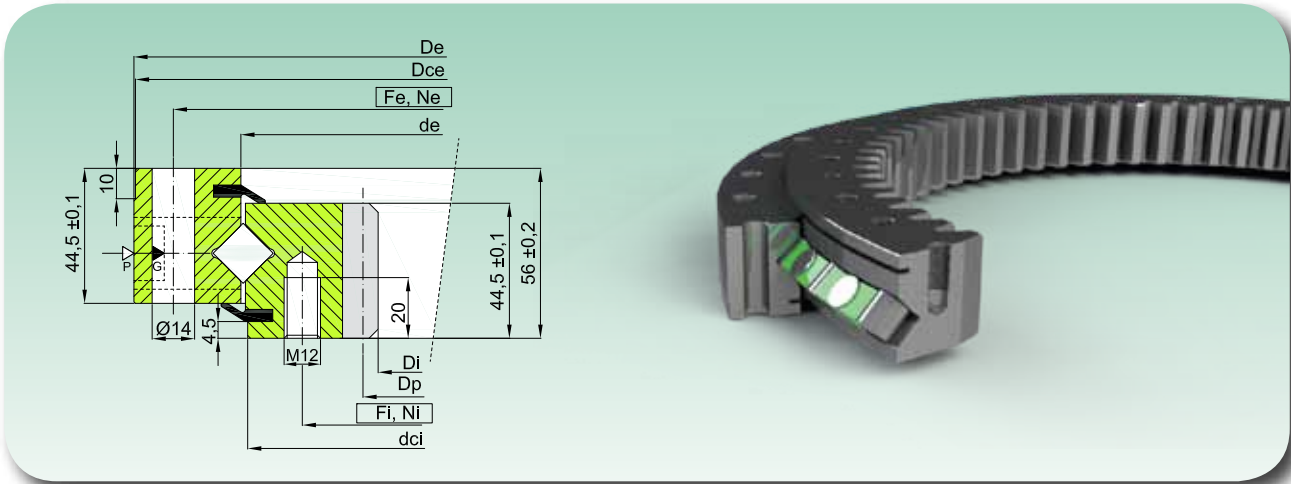

Código Code	Curva Curve	Dimensiones Dimensions				Orificios de fijación Fixing Holes					Dentado Gear data				Peso Weight [kg]	
		De [mm]	Dce -IT7 [mm]	de [mm]	dci -IT7 [mm]	Di [mm]	Fe [mm]	Ne [-]	Fi [mm]	Ni [-]	m [mm]	Z [-]	Dp [mm]	fz norm [kN]		fz max [kN]
ZR1.14.0414.200-1SPTN	1	486	484	415+0,5	411	325	460	24	375	24	5	67	335	15,76	31,52	31
ZR1.14.0544.200-1SPTN	2	616	614	545+0,5	541	444	590	32	505	32	6	76	456	18,91	37,83	43
ZR1.14.0644.200-1SPTN	3	716	714	645+0,6	641	546	690	36	605	36	6	93	558	18,91	37,83	50
ZR1.14.0744.200-1SPTN	4	816	814	745+0,6	741	648	790	40	705	40	6	110	660	18,91	37,83	58
ZR1.14.0844.200-1SPTN	5	916	914	845+0,6	841	736	890	40	805	40	8	94	752	25,22	50,43	69
ZR1.14.0944.200-1SPTN	6	1016	1014	945+0,7	941	840	990	44	905	44	8	107	856	25,22	50,43	76
ZR1.14.1094.200-1SPTN	7	1166	1164	1095+0,7	1091	984	1140	48	1055	48	8	125	1000	25,22	50,43	91

- Material: C45 Q+T
- Ensamblados con juego estrecho
- Llenos de grasa, protegidos por aceite y envueltos en resistente película plástica
- ▷ P=tapón inserción bolas / filling plug
- ▶ G=engrasadores M8X1 / greasers M8X1
- Material C45 Q+T
- Assembled with reduced clearances
- Full of grease, protected by oil and wrapped in resistant plastic film

Mf
Momento de inclinación equivalente [KNm]
Equivalent Tilting moment [KNm]

Leer las instrucciones técnicas - parte 2 - para la utilización correcta del gráfico

Please read technical instruction part 2 for correct use of load graph.



DIAGRAMA DE CARGA ESTÁTICA PARA ESFUERZOS DE COMPRESIÓN

STATIC LOAD CHARTS VALID FOR COMPRESSIVE LOADS

Fa
Carga axial equivalente [KN]
Equivalent axial load [KN]

ZR1.14 PR

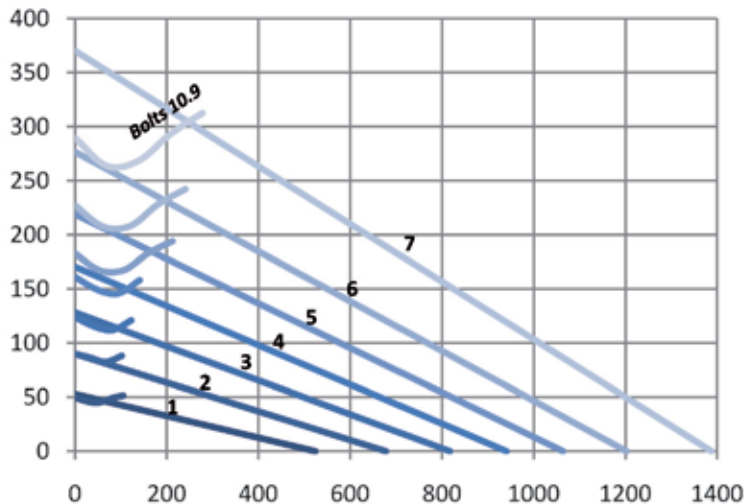
SERIE PRECARGADA DE PRECISIÓN

PRELOADED PRECISION SERIES

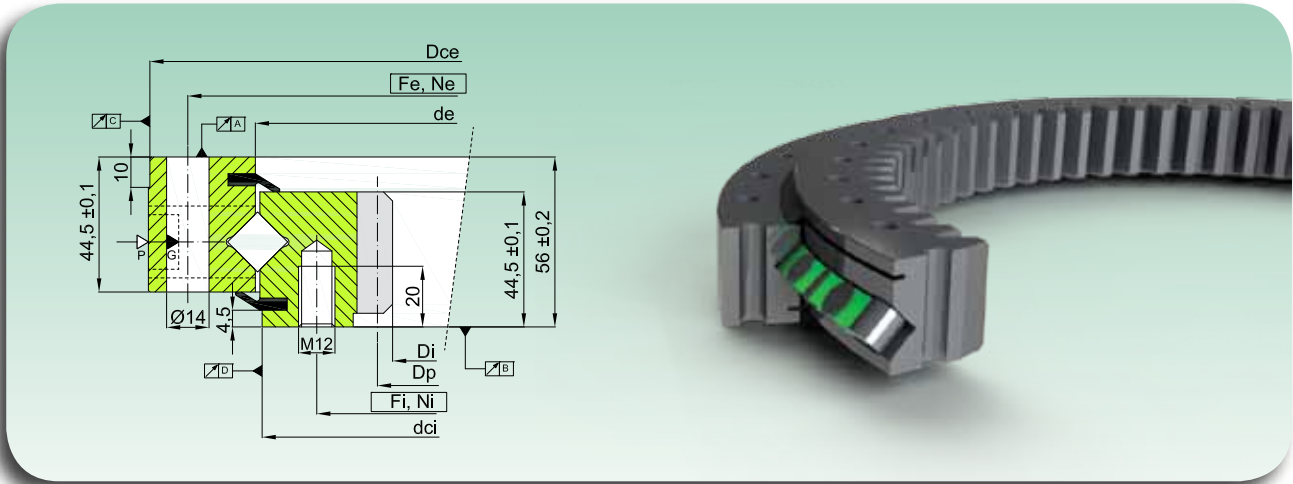

Código Code	Curva Curve	Dimensiones Dimensions				Orificios de fijación Fixing Holes				Dentado Gear data				Pre-carga Preload	Peso Weight	
		Dce +IT7 [mm]	de [mm]	dci +IT7 [mm]	dcDi [mm]	Fe [mm]	Ne [-]	Fi [mm]	Ni [-]	m [mm]	Z [-]	Dp [mm]	fz norm [kN]			fz max [kN]
ZR1.14.0414.201-3SPTN	1	484	415+0,5	411	325	460	24	375	24	5	67	335	17,7	26,2	0,01÷ -0,03	31
ZR1.14.0544.201-3SPTN	2	614	545+0,5	541	444	590	32	505	32	6	76	456	23,7	35	0,01÷ -0,03	43
ZR1.14.0644.201-3SPTN	3	714	645+0,6	641	546	690	36	605	36	6	93	558	23,7	35	0,01÷ -0,04	50
ZR1.14.0744.201-3SPTN	4	814	745+0,6	741	648	790	40	705	40	6	110	660	23,7	35	0,01÷ -0,04	58
ZR1.14.0844.201-3SPTN	5	914	845+0,6	841	736	890	40	805	40	8	94	752	31,4	46,7	0,01÷ -0,04	69
ZR1.14.0944.201-3SPTN	6	1014	945+0,7	941	840	990	44	905	44	8	107	856	31,4	46,7	0,01÷ -0,05	76
ZR1.14.1094.201-3SPTN	7	1164	1095+0,7	1091	984	1140	48	1055	48	8	125	1000	31,4	46,7	0,01÷ -0,06	91

- Material: C45Q+T
- Ensamblados con ligera pre-carga
- Llenos de grasa, protegidos por aceite y envueltos en resistente película plástica
- ▷ P=tapón inserción bolas / filling plug
- ▶ G=n.4 engrasadores M8X1 / n.4 greasers M8X1.
- Material C45 Q+T
- Assembled with slight preload
- Full of grease, protected by oil and wrapped in resistant plastic film

n.	Valores de oscilación Run-out values			
	A [mm]	B [mm]	C [mm]	D [mm]
1	0,04	0,04	0,06	0,06
2	0,04	0,04	0,07	0,06
3	0,05	0,05	0,08	0,07
4	0,05	0,05	0,08	0,08
5	0,05	0,05	0,09	0,08
6	0,06	0,06	0,09	0,09
7	0,07	0,07	0,11	0,11

EL MISMO DIAGRAMA DE CARGA SERIE ZR1.14 S
SAME LOAD CHART OF THEZR. 14 S SERIES

ZR1.16 S

SERIE ESTÁNDAR

STANDARD SERIES

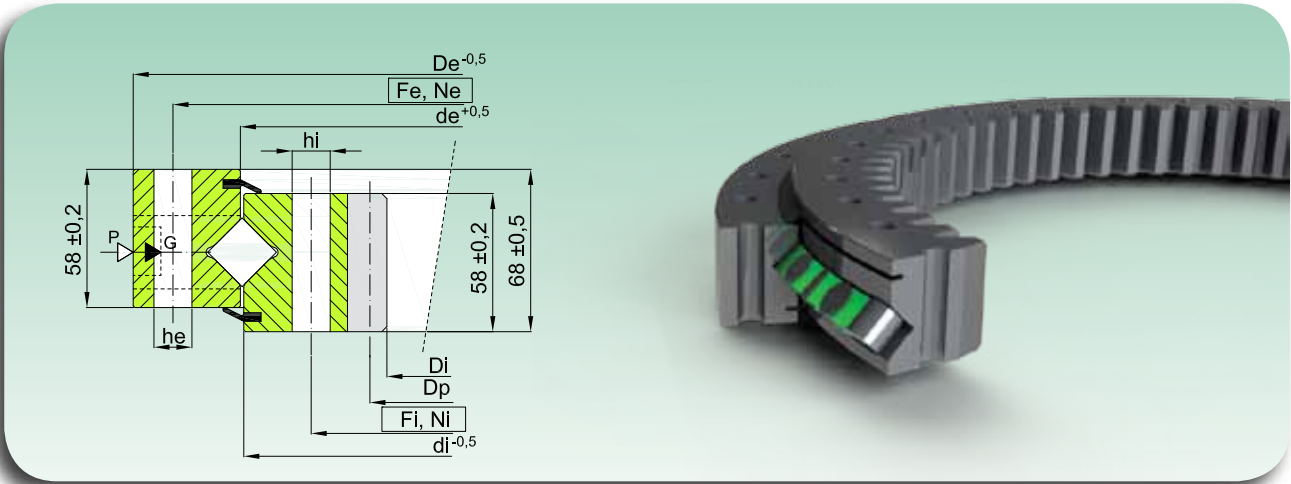

Código Code	Curva Curve	Dimensiones Dimensions				Orificios de fijación Fixing Holes						Dentado Gear data				Peso Weight [kg]	
		De [mm]	de [mm]	di [mm]	Di [mm]	Fe [mm]	Ne [-]	he [-]	Fi [mm]	Ni [-]	hi [-]	m [mm]	Z [-]	Dp [mm]	fz norm [kN]		fz max [kN]
ZR1.16.1204.400-1SPPN	1	1289	1206	1202	1072	1257	45	16	1151	45	16	10	108	1080	48,33	96,67	148
ZR1.16.1314.400-1SPPN	2	1399	1316	1312	1182	1367	50	16	1261	50	16	10	119	1190	48,33	96,67	161
ZR1.16.1424.400-1SPPN	3	1509	1426	1422	1292	1477	54	16	1371	54	16	10	130	1300	48,33	96,67	175
ZR1.16.1534.400-1SPPN	4	1619	1536	1532	1402	1587	60	16	1481	60	16	10	141	1410	48,33	96,67	189
ZR1.16.1644.400-1SPPN	5	1752	1646	1642	1495	1708	54	22	1580	54	22	10	150	1500	48,33	96,67	239
ZR1.16.1754.400-1SPPN	6	1862	1756	1752	1605	1818	60	22	1690	60	22	10	161	1610	48,33	96,67	256
ZR1.20.1904.400-1SPPN	7	2012	1906	1902	1729	1968	64	22	1840	64	22	14	124	1736	67,67	135,33	304

- Material: 42CrMo4 Q+T

- Ensamblados con juego positivo

- Llenos de grasa, protegidos por aceite y envueltos en resistente película plástica

▷ P=tapón inserción bolas / filling plug

▶ G=engrasadores M8X1 / greasers M8X1

- Material 42CrMo4 Q+T

- Assembled with positive clearances

- Full of grease, protected by oil and wrapped in resistant plastic film

Mf
Momento de inclinación equivalente [KNm]
Equivalent Tilting moment [KNm]

Leer las instrucciones técnicas - parte 2 - para la utilización correcta del gráfico

Please read technical instruction part 2 for correct use of load graph.



DIAGRAMA DE CARGA ESTÁTICA PARA ESFUERZOS DE COMPRESIÓN

STATIC LOAD CHARTS VALID FOR COMPRESSIVE LOADS

Fa

Carga axial equivalente [KN]
Equivalent axial load [KN]

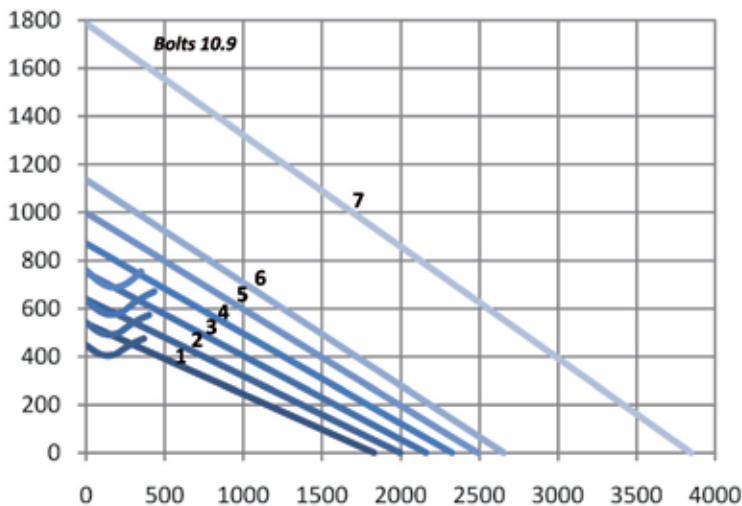
ZR1.16/25

SERIE ESTÁNDAR

STANDARD SERIES

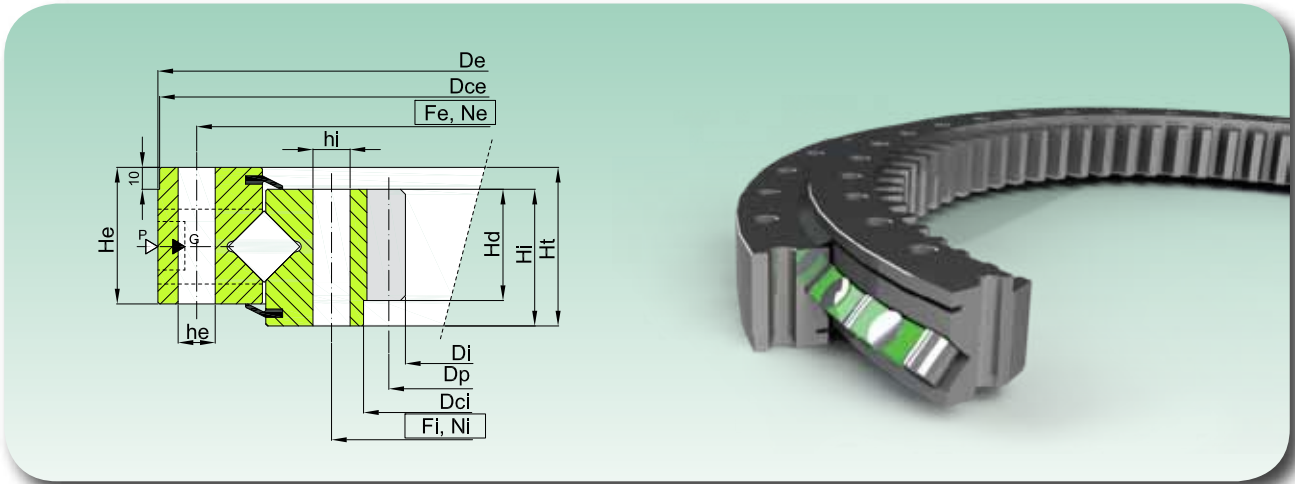

Código Code	Curva Curve	Dimensiones Dimensions								Orificios de fijación Fixing Holes						Dentado Gear data				Peso Weight [kg]
		De [mm]	Dce [mm]	Dci [mm]	Di [mm]	He [mm]	Hi [mm]	Ht [mm]	Hd [mm]	Fe [mm]	Ne [-]	he [mm]	Fi [mm]	Ni [-]	hl [-]	m [mm]	Z [-]	xm [mm]	Dp [mm]	
ZR1.16.0380.400-1SPPN	1	451	450 -0,10	313+0,09	291	55	45	45	40	425	24	13,5	335	24	13,5	5	60	-	300	28
ZR1.20.0489.400-1SPPN	2	562	560 -0,11	418+0,10	385	50	50	60	43	538	30	14	440	30	14	6	66	-	396	44
ZR1.20.0573.400-1SPPN	3	665	660 -0,13	485+0,13	457	50	50	60	45	630	28	17,5	518	28	17,5	6	77	-3	468	62
ZR1.25.0673.400-1SPPN	4-a	771	770 -0,14	575+0,11	541	60	60	70	55	736	32	17,5	610	32	17,5	6	91	-3	552	96
ZR1.25.0714.400-1SPPN	5-b	825	815 -0,14	605+0,13	567,5	62	78	90	67	785	26	18	640	20	18	7	82	-	581	135
ZR1.25.0770.400-1SPPN	6	871	870 -0,14	670+0,13	634	60	60	70	55	833	36	17,5	707	36	17,5	8	80	-4	648	112
ZR1.25.0849.400-1SPPN	7	960	958 -0,14	742+0,14	706	65	65	70	60	914	30	22	784	30	22	8	89	-4	720	14,4
ZR1.25.0946.400-1SPPN	8	1066	1065 -0,17	-	785	65	75	85	75	1015	36	22	880	36	22	10	79	-6,52	803,04	190
ZR1.25.1050.400-1SPPN	9	1170	1165 -0,17	-	882	80	88	98	75	1125	40	22	975	40	22	10	89	-	900	258

- Material: 42CrMo4 Q+T

- Ensamblados con juego estrecho / pre-carga bajo demanda

- Llenos de grasa, protegidos por aceite y envueltos en resistente película plástica

▷ P=tapón inserción bolas / filling plug

▶ G=engranadores M8X1 / greasers M8X1

- Material 42CrMo4 Q+T

- Assembled with reduced clearances / preload on request

- Full of grease, protected by oil and wrapped in resistant plastic film

Mf
Momento de inclinación equivalente [KNm]
Equivalent Tilting moment [KNm]

Leer las instrucciones técnicas - parte 2 - para la utilización correcta del gráfico

Please read technical instruction part 2 for correct use of load graph.



DIAGRAMA DE CARGA ESTÁTICA PARA ESFUERZOS DE COMPRESIÓN

STATIC LOAD CHARTS VALID FOR COMPRESSIVE LOADS

Fa

Carga axial equivalente [KN]
Equivalent axial load [KN]

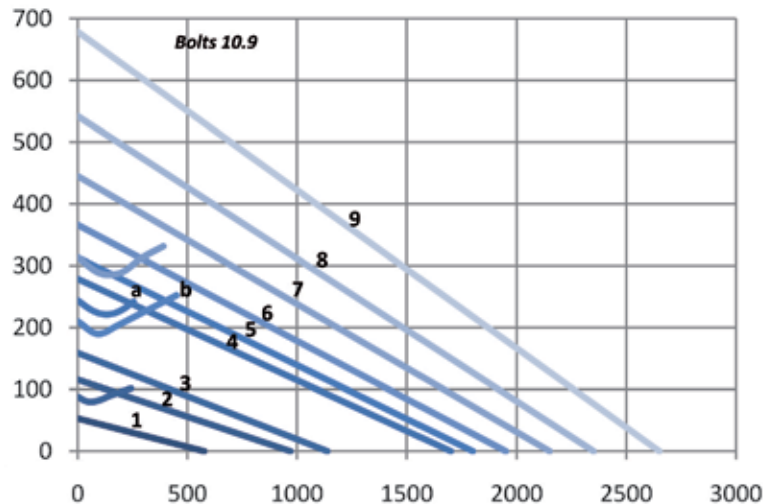
ZR1.30/50

SERIE ESTÁNDAR

STANDARD SERIES

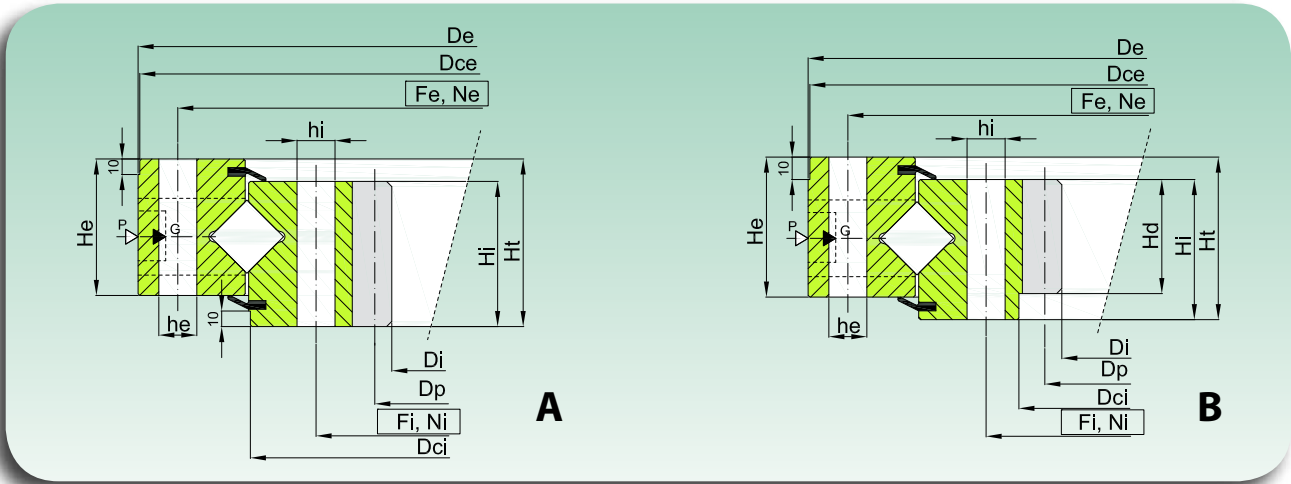

Código Code	Curva / Curve Forma / Shape	Dimensiones Dimensions								Orificios de fijación Fixing Holes					Dentado Gear data					Peso Weight [kg]	
		De [mm]	Dce [mm]	Dci [mm]	Di [mm]	He [mm]	Hi [mm]	Ht [mm]	Hd [mm]	Fe [mm]	Ne [-]	he [mm]	Fi [mm]	Ni [-]	hl [-]	m [mm]	Z [-]	xm [mm]	Dp [mm]		fz norm
ZR1.30.1140.400-1SPPN	1 A	1251	1250 -0,17	1135 -0,17	979	75	75	91	-	1212	40	22	1068	40	22	10	99	-3,2	996,4	72,5	239
ZR1.36.1304.400-1SPPN	2 A	1431	1430 -0,20	1298 -0,17	1143	82	85	97	-	1380	48	22	1228	48	22	10	115	-	1143	82,1	323
ZR1.40.1385.400-1SPPN	3 A	1530	1529 -0,20	1360 -0,20	1178	107	107	130	-	1480	36	26	1290	36	26	12	100	-	1200	107	541
ZR1.45.1606.400-1SPPN	4 B	1770	1760 -0,20	1440 +0,20	1375	125	125	150	110	1710	48	30	1500	48	30	14	100	-	1400	128,3	802
ZR1.45.1830.400-1SPPN	5 B	2002	2000 -0,25	1665 +0,20	1595	125	125	150	115	1940	54	30	1720	54	30	14	115	-4,9	1619,8	155,6	951
ZR1.50.1997.400-1SPPN	6 A	2190	2188 -0,30	1990 -0,25	1731	127	132	144	-	2130	72	30	1880	72	30	16	109	-8	1760	204,1	1199
ZR1.50.2400.400-1SPPN	7 A	2590	2586 -0,35	2392 -0,20	2110	135	145	160	-	2520	80	30	2280	80	30	18	118	-9	2142	252,2	1626
ZR1.50.2810.400-1SPPN	8 A	3020	3018 -0,40	-	2495	140	148	158	-	2950	72	36	2670	72	36	20	126	-6	2532	286	2154

- Material: 42CrMo4 Q+T

- Ensamblados con juego positivo

- Llenos de grasa, protegidos por aceite y envueltos en resistente película plástica

▷ P= tapón inserción bolas / filling plug

▶ G= engrasadores M8X1 / greasers M8X1

- Material 42CrMo4 Q+T

- Assembled with positive clearances

- Full of grease, protected by oil and wrapped in resistant plastic film

Mf
Momento de inclinación equivalente [KNm]
Equivalent Tilting moment [KNm]



DIAGRAMA DE CARGA ESTÁTICA PARA ESFUERZOS DE COMPRESIÓN

STATIC LOAD CHARTS VALID FOR COMPRESSIVE LOADS

Fa
Carga axial equivalente [KN]
Equivalent axial load [KN]

Leer las instrucciones técnicas - parte 2 - para la utilización correcta del gráfico

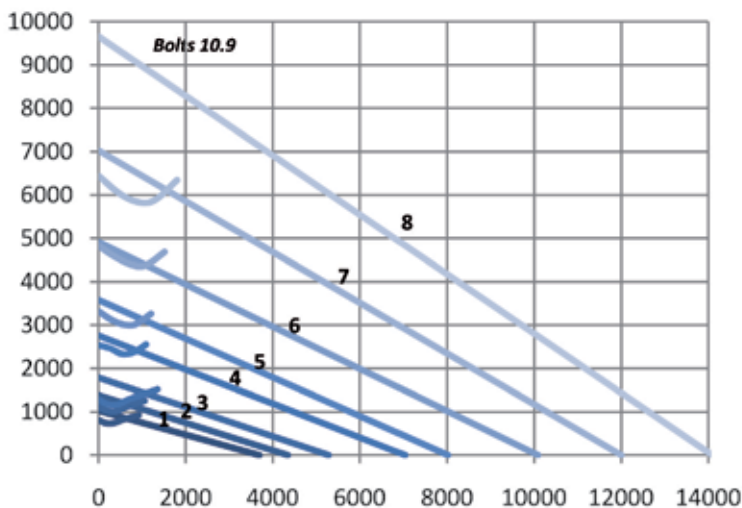
Please read technical instruction part 2 for correct use of load graph.



Coronas giratorias de una hilera de rodillos cruzados, sin dentado

One row crossed roller bearing, untoothed

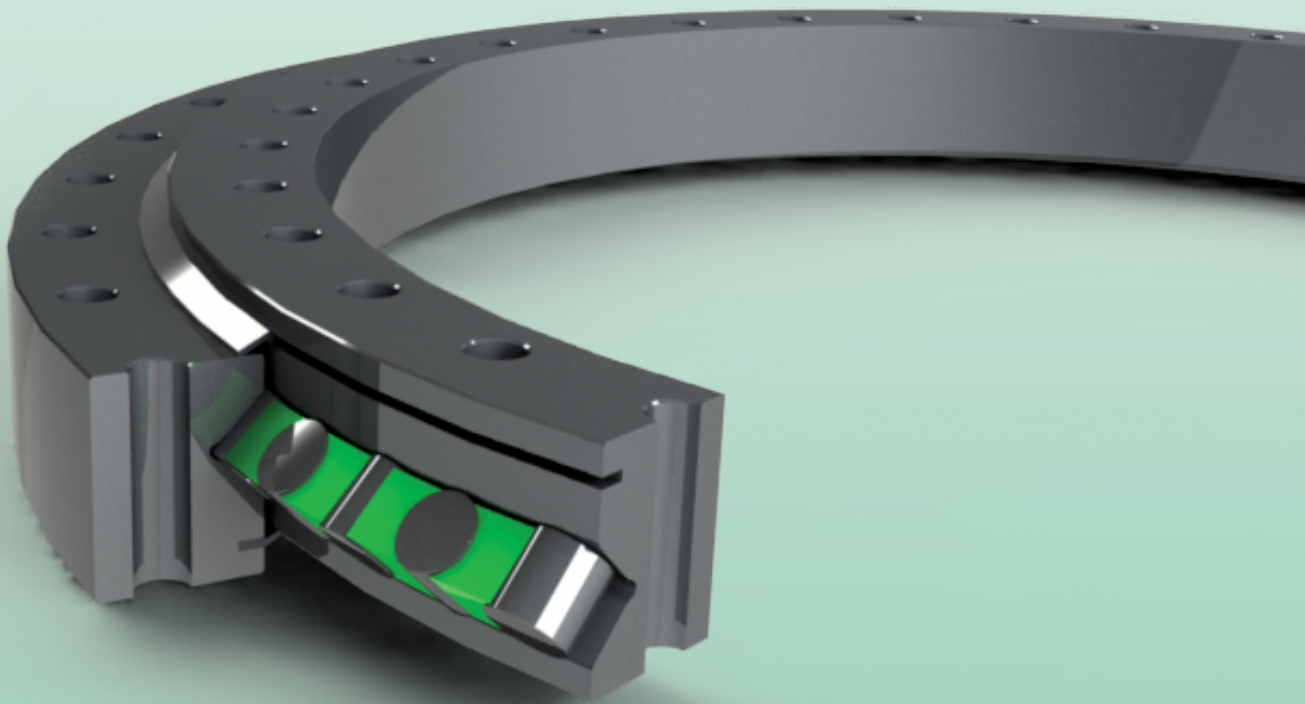

NR1 SERIES

NR1.14 S

SERIE ESTÁNDAR

STANDARD SERIES

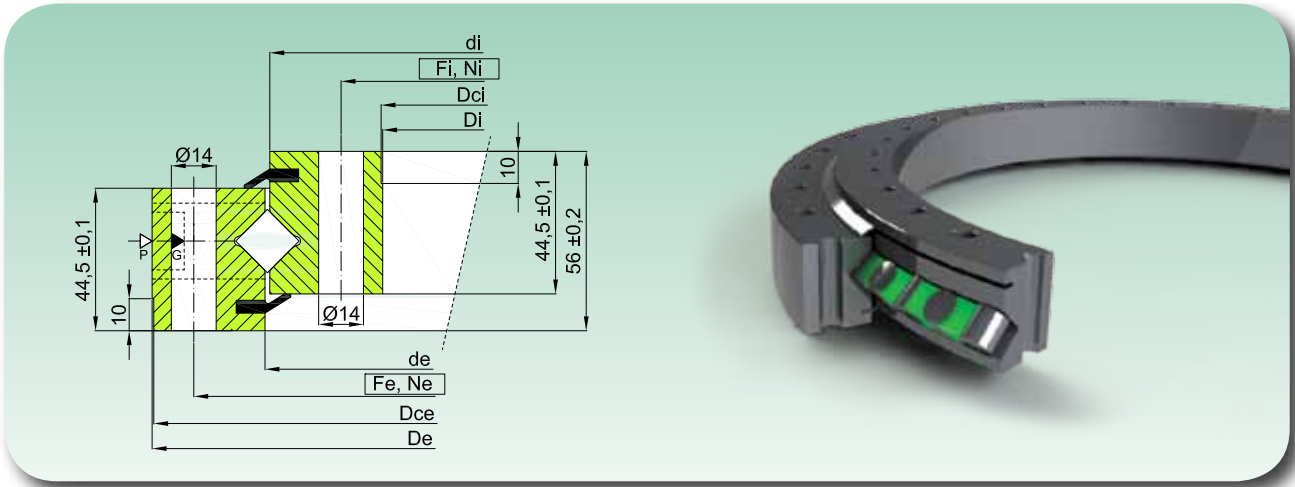

Código Code	Curva Curve	Dimensiones Dimensions						Orificios de fijación Fixing Holes				Peso Weight [kg]
		De [mm]	Dce-IT7 [mm]	de [mm]	di [mm]	Dci+IT7 [mm]	Di [-]	Fe [mm]	Ne [-]	Fi [mm]	Ni [-]	
NR1.14.0414.200-1PPN	1	486	484	415+0,5	413-0,5	344	342	460	24	368	24	28
NR1.14.0544.200-1PPN	2	616	614	545+0,5	543-0,5	474	472	590	32	498	32	38
NR1.14.0644.200-1PPN	3	716	714	645+0,6	643-0,6	574	572	690	36	598	36	44
NR1.14.0744.200-1PPN	4	816	814	745+0,6	743-0,6	674	672	790	40	698	40	52
NR1.14.0844.200-1PPN	5	916	914	845+0,6	843-0,6	774	772	890	40	798	40	60
NR1.14.0944.200-1PPN	6	1016	1014	945+0,7	943-0,7	874	872	990	44	898	44	67
NR1.14.1094.200-1PPN	7	1166	1164	1095+0,7	1093-0,7	1024	1022	1140	48	1048	48	77

- Material: C45 Q+T

- Ensamblados con juego estrecho

- Llenos de grasa, protegidos por aceite y envueltos en resistente película plástica

▷ P=tapón inserción bolas / filling plug

- Material C45 Q+T

- Assembled with reduced clearances

- Full of grease, protected by oil and wrapped in resistant plastic film

▶ G=enrasadores M8X1 / greasers M8X1

Mf
Momento de inclinación equivalente [KNm]
Equivalent Tilting moment [KNm]

Leer las instrucciones técnicas - parte 2 - para la utilización correcta del gráfico

Please read technical instruction part 2 for correct use of load graph.



DIAGRAMA DE CARGA ESTÁTICA PARA ESFUERZOS DE COMPRESIÓN

STATIC LOAD CHARTS VALID FOR COMPRESSIVE LOADS

Fa

Carga axial equivalente [KN]
Equivalent axial load [KN]

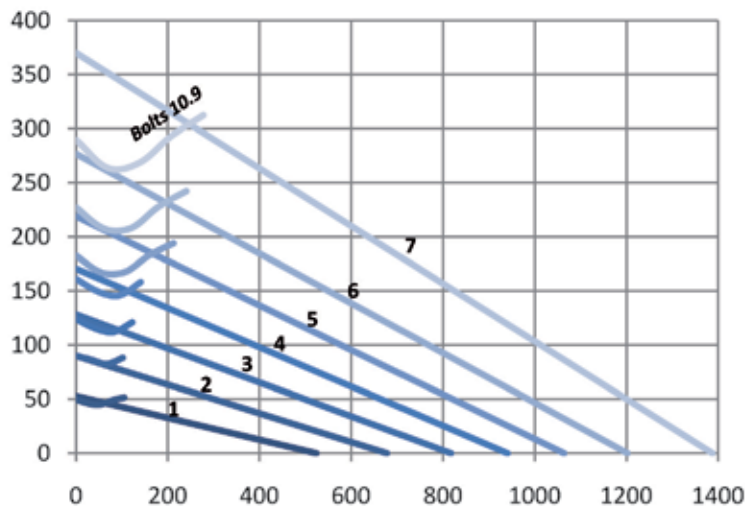
NR1.14 PR

SERIE PRECARGADA DE PRECISIÓN

PRELOADED PRECISION SERIES

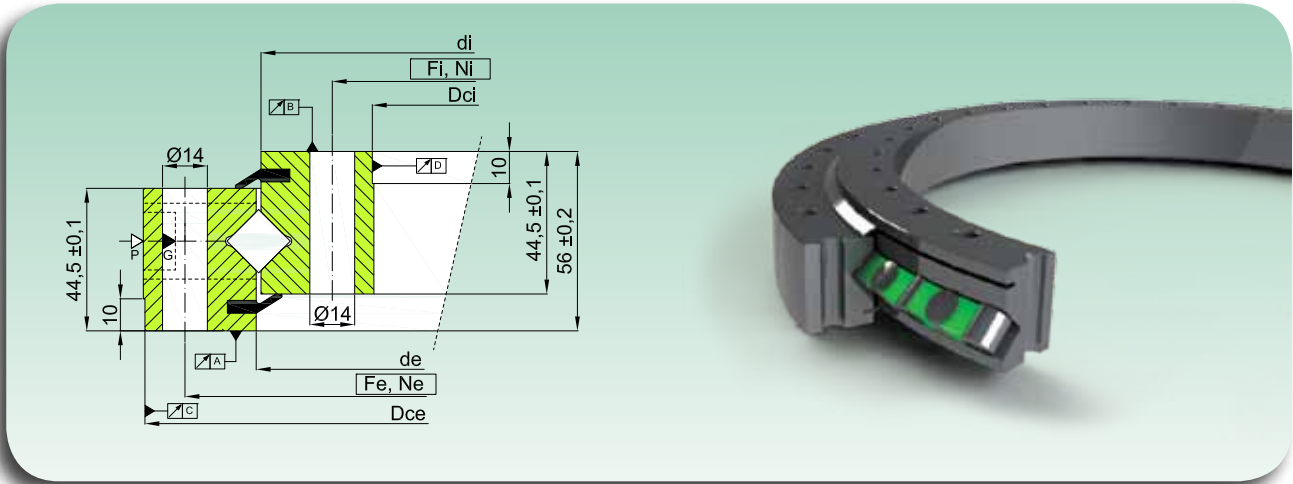

Código Code	Curva Curve	Dimensiones Dimensions				Orificios de fijación Fixing Holes				Pre-carga Preload	Peso Weight
		Dce-IT7 [mm]	de [mm]	di [mm]	Dci +IT7 [mm]	Fe [mm]	Ne [-]	Fi [mm]	Ni [-]		
NR1.14.0414.201-3PPN	1	484	415+0,5	413-0,5	344	460	24	368	24	0,01 ÷ -0,03	28
NR1.14.0544.201-3PPN	2	614	545+0,5	543-0,5	474	590	32	498	32	0,01 ÷ -0,03	38
NR1.14.0644.201-3PPN	3	714	645+0,6	643-0,6	574	690	36	598	36	0,01 ÷ -0,04	44
NR1.14.0744.201-3PPN	4	814	745+0,6	743-0,6	674	790	40	698	40	0,01 ÷ -0,04	52
NR1.14.0844.201-3PPN	5	914	845+0,6	843-0,6	774	890	40	798	40	0,01 ÷ -0,04	60
NR1.14.0944.201-3PPN	6	1014	945+0,7	943-0,7	874	990	44	898	44	0,01 ÷ -0,05	67
NR1.14.1094.201-3PPN	7	1164	1095+0,7	1093-0,7	1024	1140	48	1048	48	0,01 ÷ -0,06	77

- Material: C45Q+T

- Ensamblados con ligera pre-carga

- Llenos de grasa, protegidos por aceite y envueltos en resistente película plástica

▷ P=tapón inserción bolas / filling plug

- Material C45 Q+T

- Assembled with slight preload

- Full of grease, protected by oil and wrapped in resistant plastic film

▶ G= n.4 engrasadores M8X1 / n.4 greasers M8X1.

n.	Valores de oscilación Run-out values			
	A [mm]	B [mm]	C [mm]	D [mm]
1	0,04	0,04	0,06	0,06
2	0,04	0,04	0,07	0,06
3	0,05	0,05	0,08	0,07
4	0,05	0,05	0,08	0,08
5	0,05	0,05	0,09	0,08
6	0,06	0,06	0,09	0,09
7	0,07	0,07	0,11	0,11

EL MISMO DIAGRAMA DE CARGA SERIE NR1.14 S
SAME LOAD CHART OF THE NR.14 S SERIES

NR1.16 S

SERIE ESTÁNDAR

STANDARD SERIES

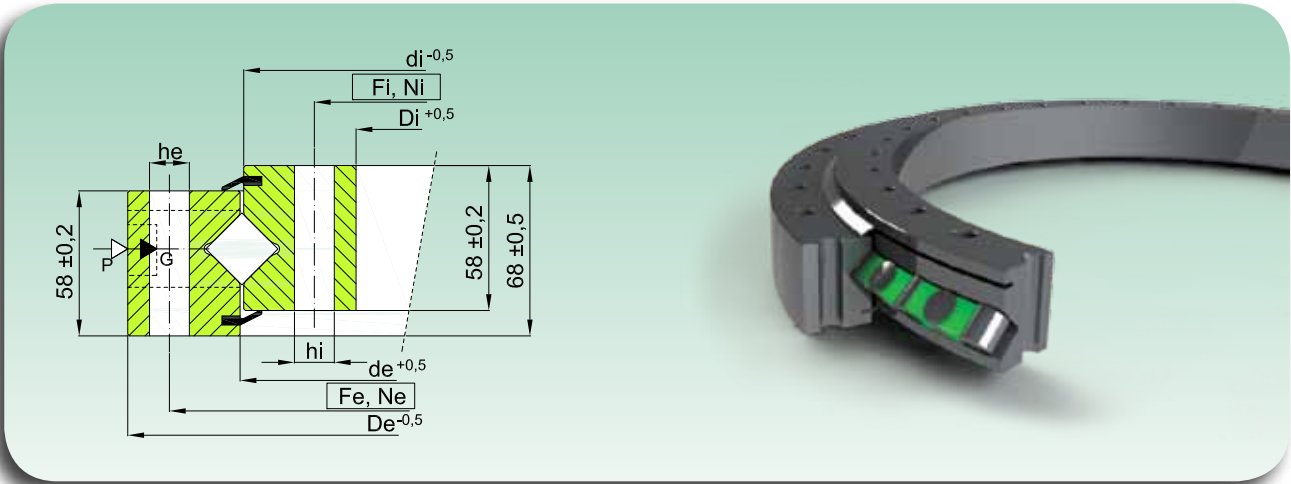

Código Code	Curva Curve	Dimensiones Dimensions				Orificios de fijación Fixing Holes						Peso Weight [kg]
		De [mm]	de [mm]	di [mm]	Di [mm]	Fe [mm]	Ne [-]	he [mm]	Fi [mm]	Ni [-]	hi [mm]	
NR1.16.1204.400-1PPN	1	1289	1206	1202	1119	1257	45	16	1151	45	16	124
NR1.16.1314.400-1PPN	2	1399	1316	1312	1229	1367	50	16	1261	50	16	135
NR1.16.1424.400-1PPN	3	1509	1426	1422	1339	1477	54	16	1371	54	16	146
NR1.16.1534.400-1PPN	4	1619	1536	1532	1449	1587	60	16	1481	60	16	158
NR1.16.1644.400-1PPN	5	1752	1646	1642	1536	1708	54	22	1580	54	22	214
NR1.16.1754.400-1PPN	6	1862	1756	1752	1646	1818	60	22	1690	60	22	228
NR1.20.1904.400-1PPN	7	2012	1906	1902	1796	1968	64	22	1840	64	22	248

- Material: 42CrMo4 Q+T
- Ensamblados con juego positivo
- Llenos de grasa, protegidos por aceite y envueltos en resistente película plástica
- ▷ P=tapón inserción bolas / filling plug
- ▶ G=engrasadores M8X1 / greasers M8X1
- Material 42CrMo4 Q+T
- Assembled with positive clearances
- Full of grease, protected by oil and wrapped in resistant plastic film

Mf
Momento de inclinación equivalente [KNm]
Equivalent Tilting moment [KNm]



DIAGRAMA DE CARGA ESTÁTICA PARA ESFUERZOS DE COMPRESIÓN

STATIC LOAD CHARTS VALID FOR COMPRESSIVE LOADS

Fa
Carga axial equivalente [KN]
Equivalent axial load [KN]

Leer las instrucciones técnicas - parte 2 - para la utilización correcta del gráfico

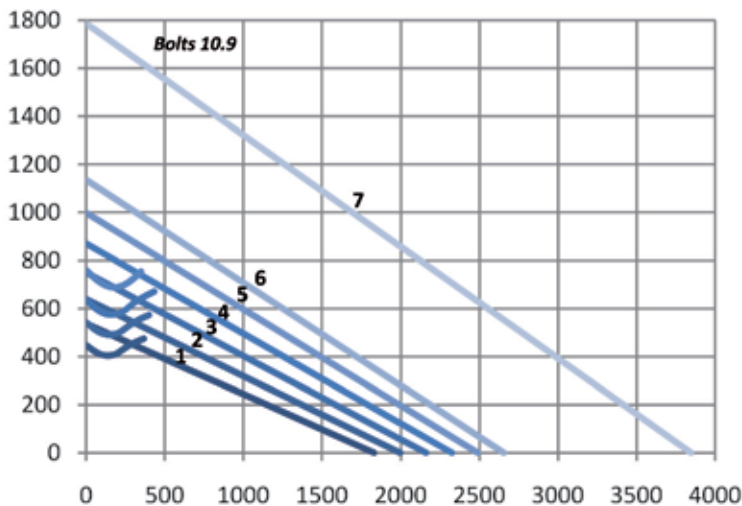
Please read technical instruction part 2 for correct use of load graph.



Coronas giratorias de tres hileras de rodillos, dentado exterior

Triple row roller bearing, external toothed

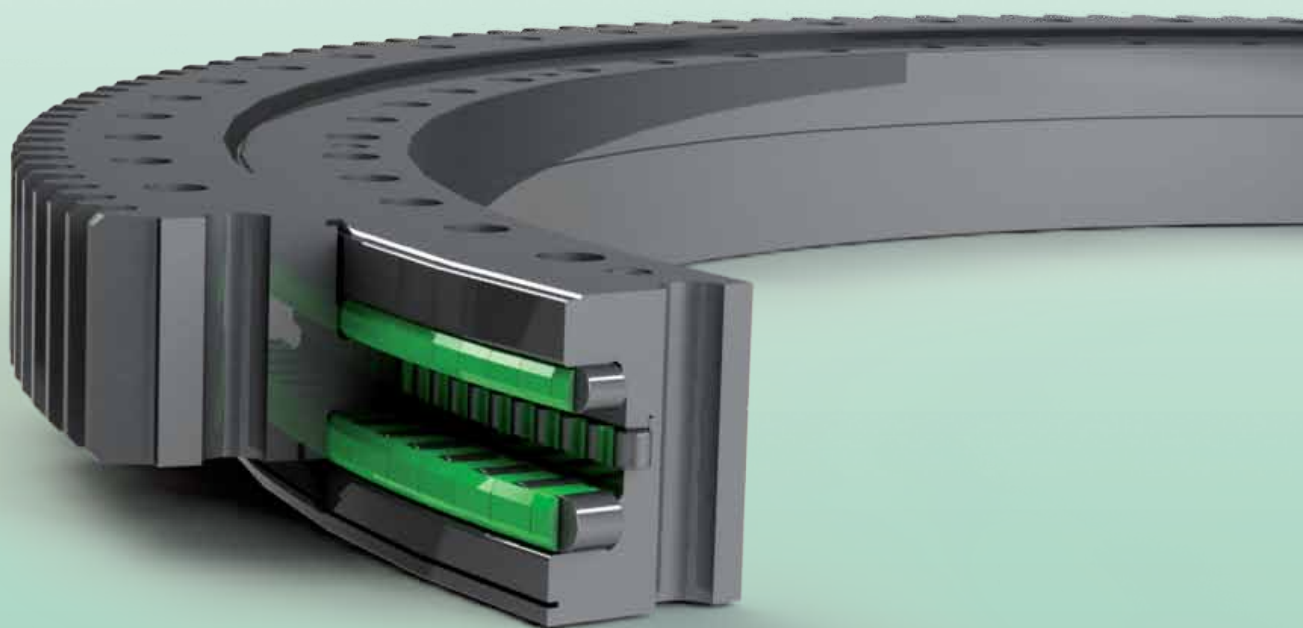

ER3 SERIES

ER3.20/25

SERIE ESTÁNDAR

STANDARD SERIES

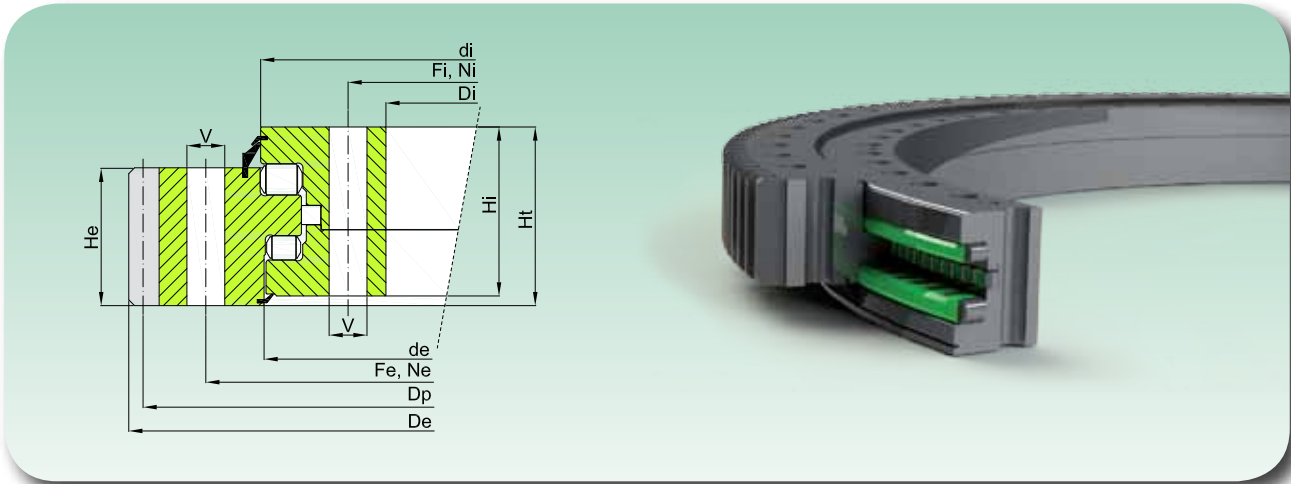

Código Code	Curva Curve	Dimensiones Dimensions						Orificios de fijación Fixing Holes				Dentado Gear data					Peso Weight [kg]		
		De [mm]	de [mm]	di [mm]	Di [mm]	He [mm]	Hi [mm]	Ht [mm]	Fe [mm]	Fi [mm]	N [-]	V [mm]	m [mm]	Z [-]	xm [mm]	Dp [mm]		fz norm [kN]	fz max [kN]
ER3.20.1250.400-1SPPN	1	1461,6	1282	1280	1103	106	123	132	1355	1155	36	26	12	119	+0.50	1428	107	187	542
ER3.20.1400.400-1SPPN	2	1635,2	1432	1430	1253	106	123	132	1505	1305	36	26	14	114	+0.50	1596	136	236	646
ER3.20.1600.400-1SPPN	3	1831,2	1632	1630	1453	106	123	132	1705	1505	40	26	14	128	+0.50	1792	136	236	731
ER3.20.1800.400-1SPPN	4	2044,8	1832	1830	1653	106	123	132	1905	1705	46	26	16	125	+0.50	2000	163	285	844
ER3.20.2000.400-1SPPN	5	2236,8	2032	2030	1853	106	123	132	2105	1905	54	26	16	137	+0.50	2192	163	285	912
ER3.25.1800.400-1SPPN	6	2076,8	1826	1836	1619	117	138	147	1925	1685	36	33	16	127	+0.50	2032	172	306	1126
ER3.25.2000.400-1SPPN	7	2268,8	2026	2036	1819	117	138	147	2125	1885	44	33	16	139	+0.50	2224	172	306	1216
ER3.25.2240.400-1SPPN	8	2516,4	2266	2276	2059	117	138	147	2366	2125	48	33	18	137	+0.50	2466	202	358	1378
ER3.25.2500.400-1SPPN	9	2786,4	2526	2536	2319	117	138	147	2625	2385	54	33	18	152	+0.50	2736	202	358	1567
ER3.25.2800.400-1SPPN	10	3096	2826	2836	2619	117	138	147	2925	2685	60	33	20	152	+0.50	3040	232	407	1785

- Material: 42CrMo4 Q+T

- Ensamblados con juego positivo

- Llenos de grasa, protegidos por aceite y envueltos en resistente película plástica

- Material 42CrMo4 Q+T

- Assembled with positive clearances

- Full of grease, protected by oil and wrapped in resistant plastic film

DIAGRAMA DE CARGA ESTÁTICA PARA ESFUERZOS DE COMPRESIÓN
 STATIC LOAD CHARTS VALID FOR COMPRESSIVE LOADS

CURVAS / CURVES 1~5

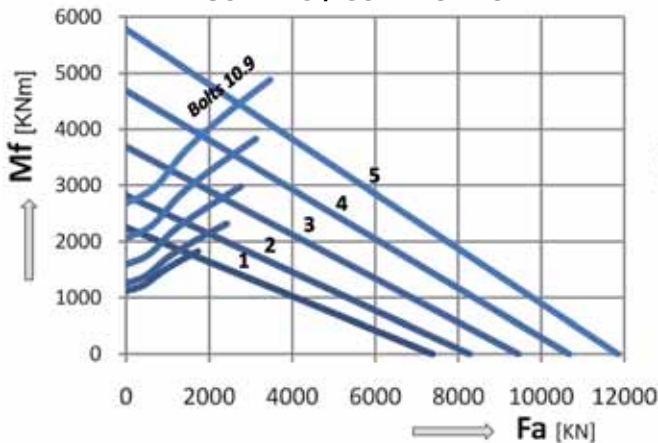

CURVAS / CURVES 6~10

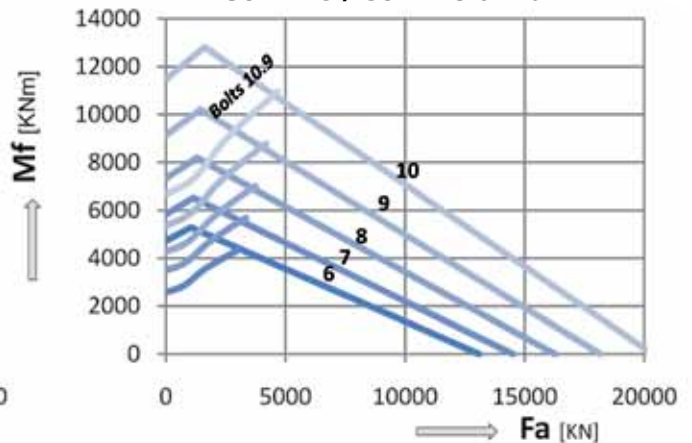

Leer las instrucciones técnicas - parte 2 - para la utilización correcta del gráfico - Please read technical instruction - part 2 - for correct use of load graph.

ER3.32/40

SERIE ESTÁNDAR

STANDARD SERIES

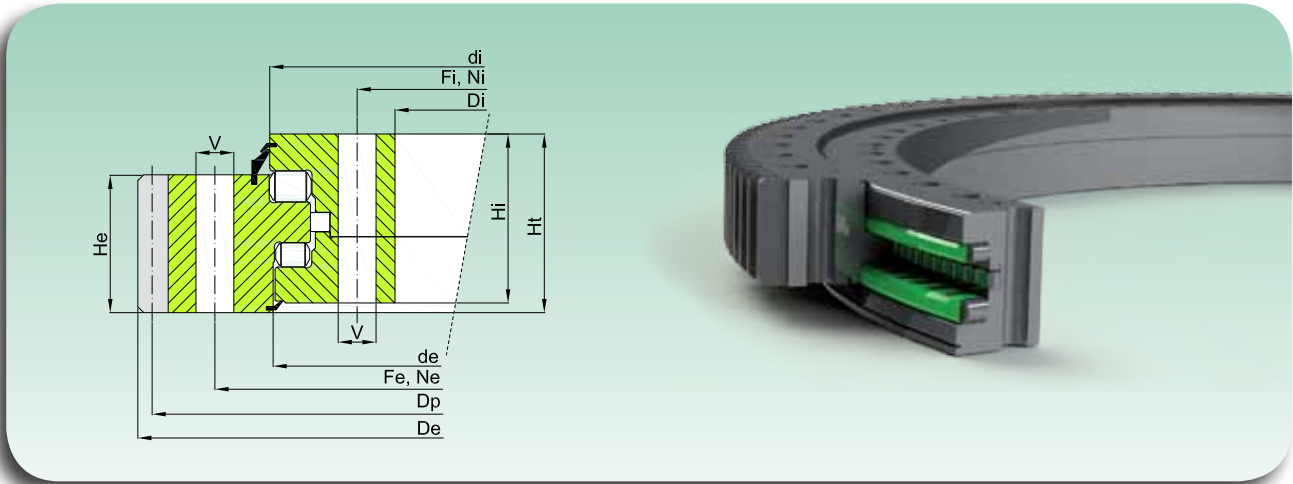

Código Code	Curva Curve	Dimensiones Dimensions							Orificios de fijación Fixing Holes				Dentado Gear data					Peso Weight [kg]	
		De [mm]	de [mm]	di [mm]	Di [mm]	He [mm]	Hi [mm]	Ht [mm]	Fe [mm]	Fi [mm]	N [-]	V [mm]	m [mm]	Z [-]	xm [mm]	Dp [mm]	fz norm [kN]		fz max [kN]
ER3.32.2240.400-1SPPN	1	2552,4	2270	2281	2022	139	172	181	2395	2100	40	39	18	139	+0.50	2502	228	401	1975
ER3.32.2500.400-1SPPN	2	2822,4	2530	2541	2282	139	172	181	2655	2360	44	39	18	154	+0.50	2772	228	401	2260
ER3.32.2800.400-1SPPN	3	3.136	2830	2841	2582	139	172	181	2955	2660	48	39	20	154	+0.50	3080	260	465	2576
ER3.32.3150.400-1SPPN	4	3.476	3180	3191	2932	139	172	181	3305	3010	56	39	20	171	+0.50	3420	260	465	2828
ER3.32.3550.400-1SPPN	5	3889,6	3580	3591	3332	139	172	181	3705	3410	66	39	22	174	+0.50	3828	295	525	3249
ER3.32.4000.400-1SPPN	6	4351,6	4030	4041	3782	139	172	181	4155	3860	72	39	22	195	+0.50	4290	295	525	3752
ER3.40.2800.400-1SPPN	7	3.136	2837	2850	2562	210	170	220	2965	2640	48	39	20	154	+0.50	3080	296	525	3267
ER3.40.3150.400-1SPPN	8	3515,6	3187	3200	2912	210	170	220	3315	2990	56	39	22	157	+0.50	3454	338	605	3812
ER3.40.3550.400-1SPPN	9	3911,6	3587	3600	3312	210	170	220	3715	3390	66	39	22	175	+0.50	3850	338	605	4255
ER3.40.4000.400-1SPPN	10	4363,2	4037	4050	3762	210	170	220	4165	3840	72	39	24	179	+0.50	4296	380	685	4805
ER3.40.4500.400-1SPPN	11	4867,2	4537	4550	4262	210	170	220	4665	4340	84	39	24	200	+0.50	4800	380	685	5410

- Material: 42CrMo4 Q+T

- Ensamblados con juego positivo

- Llenos de grasa, protegidos por aceite y envueltos en resistente película plástica

- Material 42CrMo4 Q+T

- Assembled with positive clearances

- Full of grease, protected by oil and wrapped in resistant plastic film

DIAGRAMA DE CARGA ESTÁTICA PARA ESFUERZOS DE COMPRESIÓN
 STATIC LOAD CHARTS VALID FOR COMPRESSIVE LOADS

CURVAS / CURVES 1~5

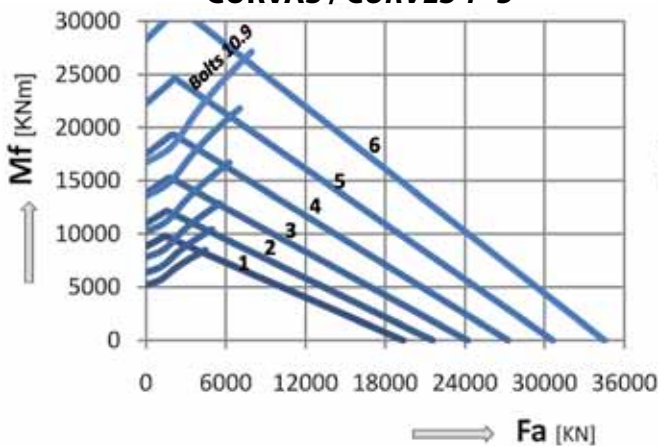

CURVAS / CURVES 7~11

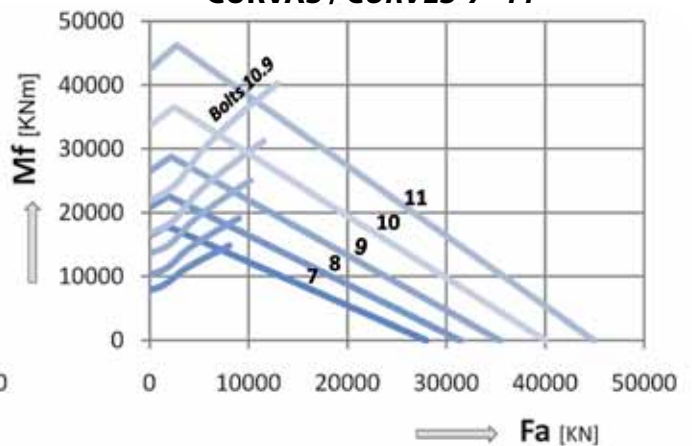

Leer las instrucciones técnicas - parte 2 - para la utilización correcta del gráfico - Please read technical instruction - part 2 - for correct use of load graph.





Coronas giratorias de tres hileras de rodillos, dentado interior

Triple row roller bearing, internal toothed

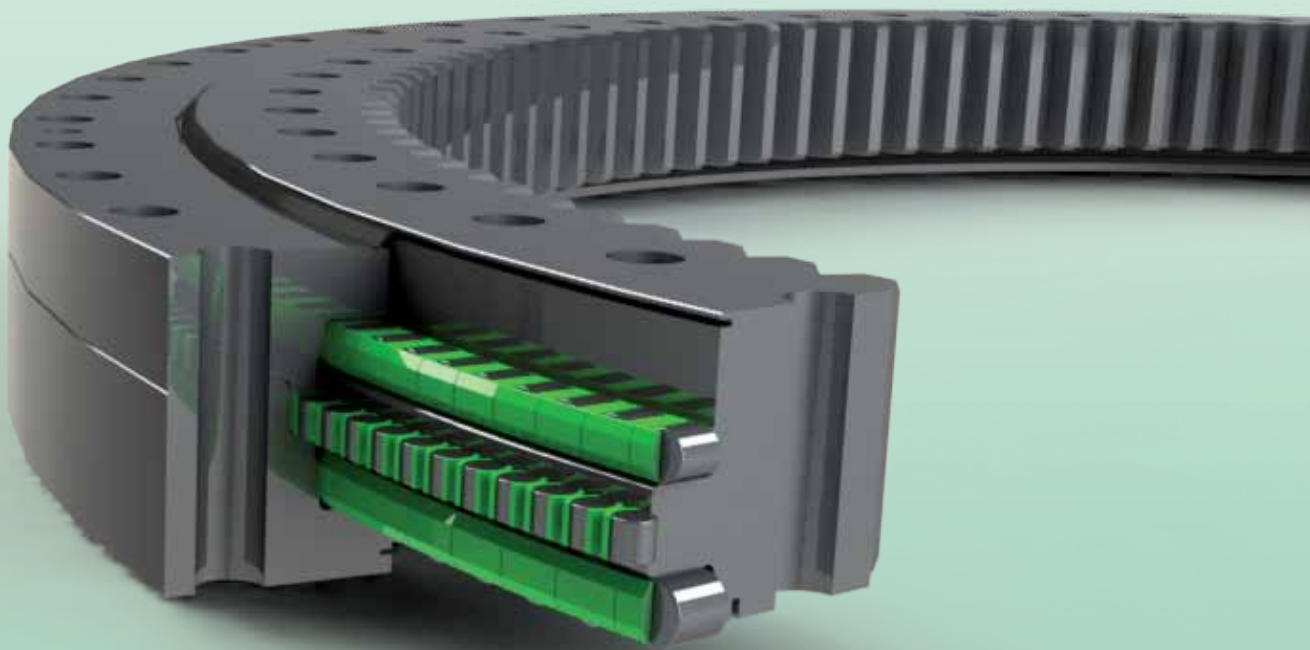

ZR3 SERIES

ZR3.20/25

SERIE ESTÁNDAR STANDARD SERIES

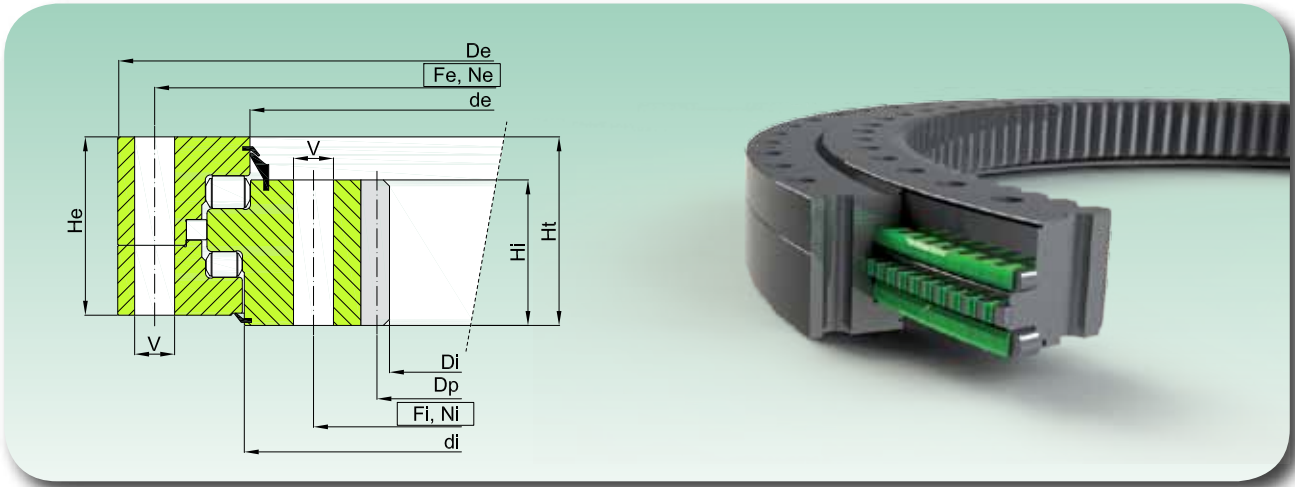

Código Code	Curva Curve	Dimensiones Dimensions						Orificios de fijación Fixing Holes				Dentado Gear data					Peso Weight [kg]		
		De [mm]	de [mm]	di [mm]	Di [mm]	He [mm]	Hi [mm]	Ht [mm]	Fe [mm]	Fi [-]	N [-]	V [mm]	m [mm]	Z [-]	x [mm]	Dp [mm]		fz norm [kN]	fz max [kN]
ZR3.20.1250.400-1SPPN	1	1397	1219	1218	1032	123	106	132	1345	1145	36	26	12	87	-0,5	1044	117	214	539
ZR3.20.1400.400-1SPPN	2	1547	1369	1368	1162	123	106	132	1495	1295	36	26	14	84	-0,5	1176	146	269	630
ZR3.20.1600.400-1SPPN	3	1747	1569	1568	1372	123	106	132	1695	1495	40	26	14	99	-0,5	1386	146	269	705
ZR3.20.1800.400-1SPPN	4	1947	1769	1768	1552	123	106	132	1895	1695	46	26	16	98	-0,5	1568	175	319	829
ZR3.20.2000.400-1SPPN	5	2147	1969	1968	1760	123	106	132	2095	1895	54	26	16	111	-0,5	1776	175	319	902
ZR3.25.1800.400-1SPPN	6	1981	1763	1774	1520	138	117	147	1915	1675	36	33	16	96	-0,5	1536	185	342	1101
ZR3.25.2000.400-1SPPN	7	2181	1963	1974	1728	138	117	147	2115	1875	44	33	16	109	-0,5	1744	185	342	1202
ZR3.25.2240.400-1SPPN	8	2421	2203	2214	1944	138	117	147	2355	2115	48	33	18	109	-0,5	1962	217	394	1406
ZR3.25.2500.400-1SPPN	9	2681	2463	2474	2214	138	117	147	2615	2375	54	33	18	124	-0,5	2232	217	394	1545
ZR3.25.2800.400-1SPPN	10	2981	2763	2774	2500	138	117	147	2915	2675	60	33	20	126	-0,5	2520	248	449	1767

- Material: 42CrMo4 Q+T

- Ensamblados con juego positivo

- Llenos de grasa, protegidos por aceite y envueltos en resistente película plástica

- Material 42CrMo4 Q+T

- Assembled with positive clearances

- Full of grease, protected by oil and wrapped in resistant plastic film

DIAGRAMA DE CARGA ESTÁTICA PARA ESFUERZOS DE COMPRESIÓN STATIC LOAD CHARTS VALID FOR COMPRESSIVE LOADS

CURVAS / CURVES 1~5

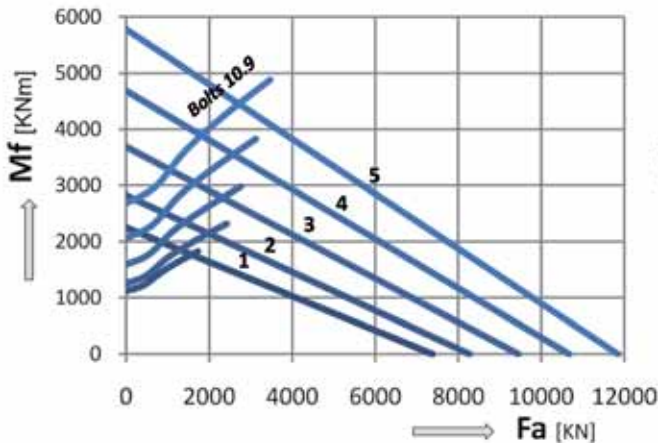

CURVAS / CURVES 6~10

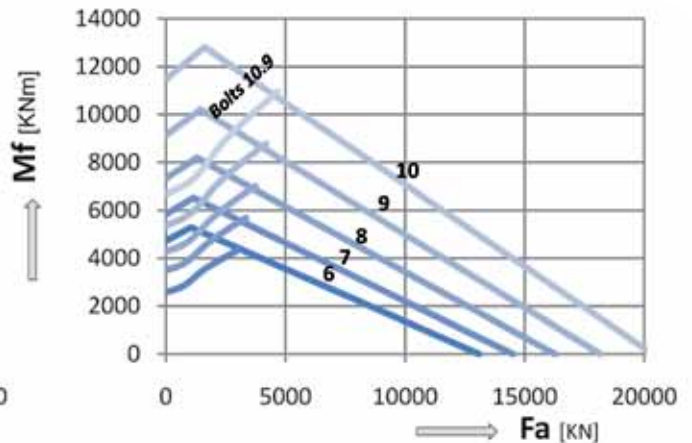

Leer las instrucciones técnicas - parte 2 - para la utilización correcta del gráfico - Please read technical instruction - part 2 - for correct use of load graph.

ZR3.32/40

SERIE ESTÁNDAR

STANDARD SERIES

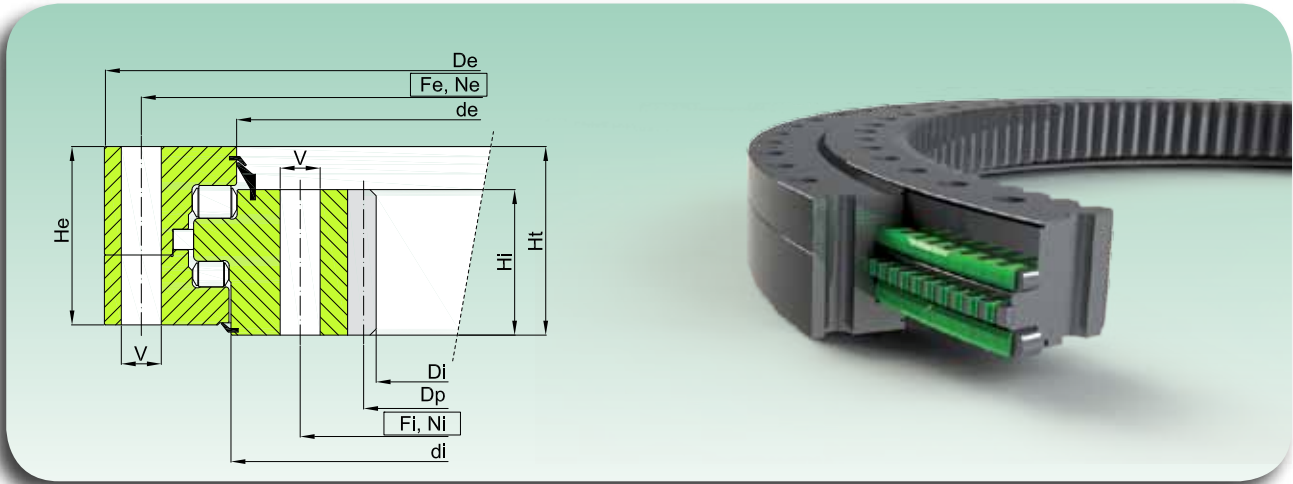

Código Code	Curva Curve	Dimensiones Dimensions							Orificios de fijación Fixing Holes				Dentado Gear data					Peso Weight [kg]	
		De [mm]	de [mm]	di [mm]	Di [mm]	He [mm]	Hi [mm]	Ht [mm]	Fe [mm]	Fi [-]	N [-]	V [mm]	m [mm]	Z [-]	x [mm]	Dp [mm]	fz norm [kN]		fz max [kN]
ZR3.32.2240.400-1SPPN	1	2458	2199	2210	1908	172	139	181	2380	2085	40	39	18	107	-0,5	1926	240	445	2010
ZR3.32.2500.400-1SPPN	2	2718	2459	2470	2178	172	139	181	2640	2345	44	39	18	122	-0,5	2196	240	445	2210
ZR3.32.2800.400-1SPPN	3	3018	2759	2770	2460	172	139	181	2940	2645	48	39	20	124	-0,5	2480	278	508	2542
ZR3.32.3150.400-1SPPN	4	3368	3109	3120	2820	172	139	181	3290	2995	56	39	20	142	-0,5	2840	278	508	2807
ZR3.32.3550.400-1SPPN	5	3768	3509	3520	3190	172	139	181	3690	3395	66	39	22	146	-0,5	3212	305	559	3302
ZR3.32.4000.400-1SPPN	6	4218	3959	3970	3652	172	139	181	4140	3845	72	39	22	167	-0,5	3674	305	559	3664
ZR3.40.2800.400-1SPPN	7	3038	2750	2763	2460	170	210	220	2960	2635	48	39	20	124	-0,5	2480	314	577	3213
ZR3.40.3150.400-1SPPN	8	3388	3100	3113	2794	170	210	220	3310	2985	56	39	22	128	-0,5	2816	357	658	3683
ZR3.40.3550.400-1SPPN	9	3788	3500	3513	3190	170	210	220	3710	3385	66	39	22	146	-0,5	3212	357	658	4171
ZR3.40.4000.400-1SPPN	10	4238	3950	3963	3624	170	210	220	4160	3835	72	39	24	152	-0,5	3648	398	740	4810
ZR3.40.4500.400-1SPPN	11	4738	4450	4463	4128	170	210	220	4660	4335	84	39	24	173	-0,5	4152	398	740	5367

- Material: 42CrMo4 Q+T

- Ensamblados con juego positivo

- Llenos de grasa, protegidos por aceite y envueltos en resistente película plástica

- Material 42CrMo4 Q+T

- Assembled with positive clearances

- Full of grease, protected by oil and wrapped in resistant plastic film

DIAGRAMA DE CARGA ESTÁTICA PARA ESFUERZOS DE COMPRESIÓN STATIC LOAD CHARTS VALID FOR COMPRESSIVE LOADS

CURVAS / CURVES 1~6

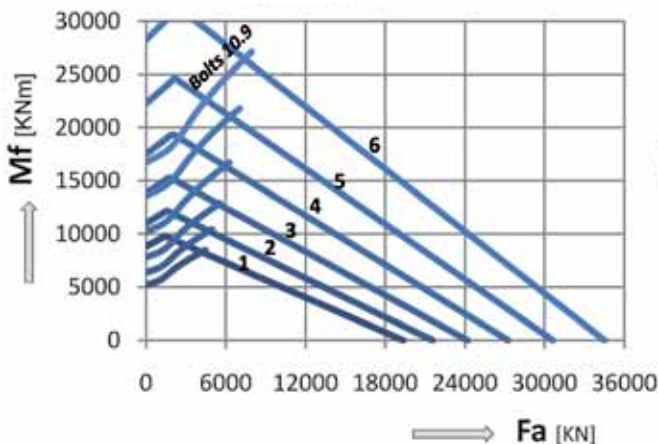

CURVAS / CURVES 7~11

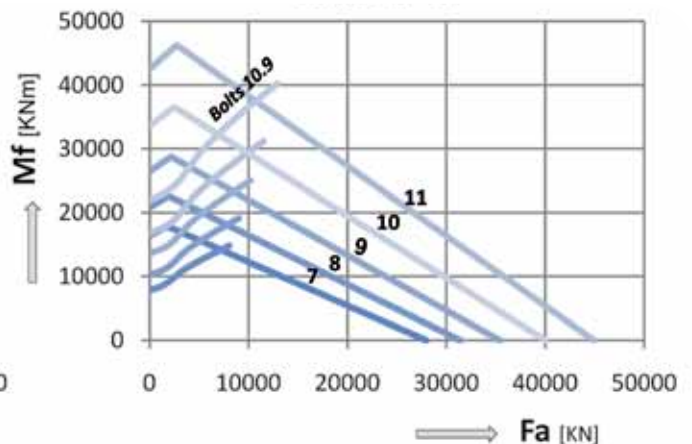

Leer las instrucciones técnicas - parte 2 - para la utilización correcta del gráfico - Please read technical instruction - part 2 - for correct use of load graph.





Serie de rodillos cruzados para rotación de precisión

Crossed roller series for precision rotation

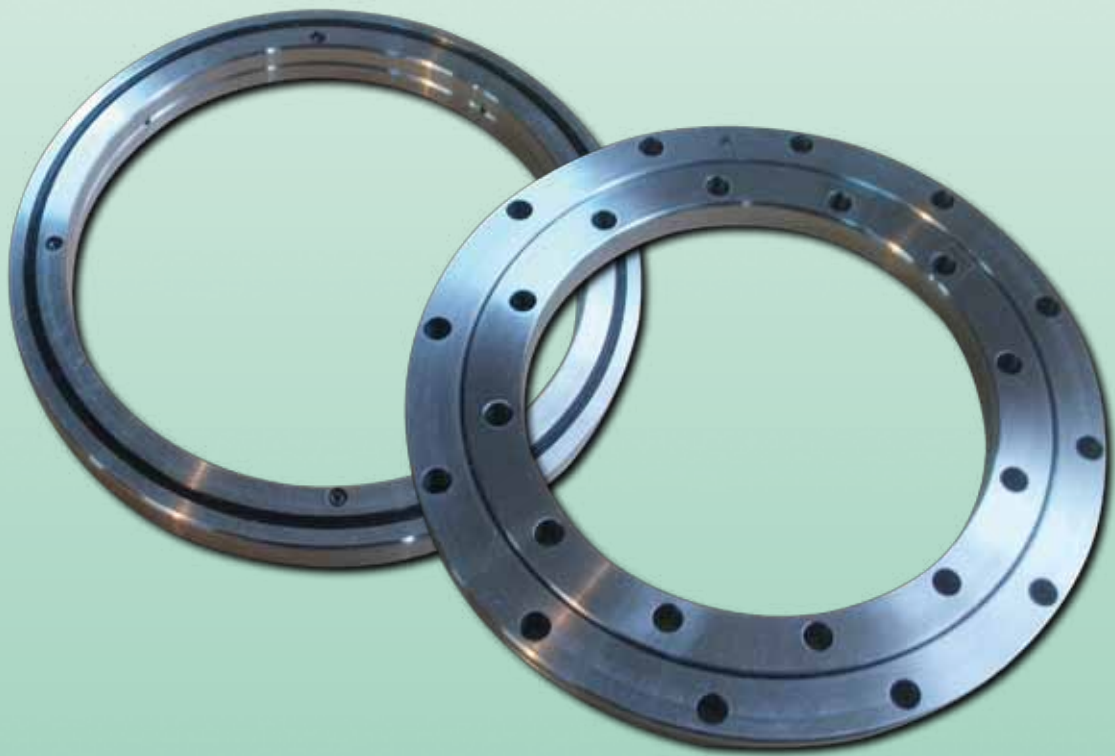

**RB/RE/RU
CRBC/CRBH/SX** SERIES

RB

SERIE DE PRECISI3N DE RODILLOS CRUZADOS

CROSSED ROLLER PRECISION SERIES

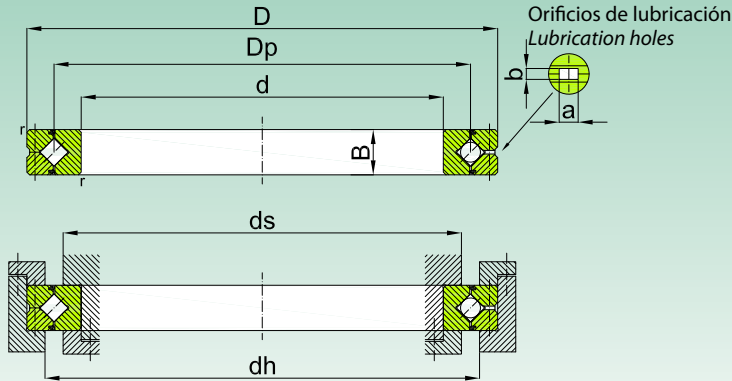

Diámetro eje Shaft diameter	Código Code	Dimensiones Dimensions					Orificios engrasadores Greasing holes		Diámetro apoyos Housing diameter		Coeficiente de carga Basic load rating		Peso Weight
		d [mm]	D [mm]	B [mm]	Dp [mm]	(rpm)	a [mm]	b [mm]	ds [mm]	dh [mm]	C [KN]	Co [KN]	
50	RB 5013	50	80	13	64	1	2,5	1,6	57,4	72	16,7	20,9	0,27
60	RB 6013	60	90	13	74	1	2,5	1,6	68	82	18	24,3	0,3
70	RB 7013	70	100	13	84	1	2,5	1,6	78	92	19,4	27,7	0,35
80	RB 8016	80	120	16	98	1	3	1,6	91	111	30,1	42,1	0,7
90	RB 9016	90	130	16	108	1,5	3	1,6	98	118	31,4	45,3	0,75
100	RB 10016	100	140	16	119,3	1,5	3,5	1,6	109	129	31,7	48,6	0,83
	RB 10020		150	20	123	1,5	3,5	1,6	113	133	33,1	50,9	1,45
110	RB 11012	110	135	12	121,8	1	2,5	1	117	127	12,5	24,1	0,4
	RB 11015		145	15	126,5	1	3,5	1,6	122	136	23,7	41,5	0,75
	RB 11020		160	20	133	1,5	3,5	1,6	120	140	34	54	1,56
120	RB 12016	120	150	16	134,2	1	3,5	1,6	127	141	24,2	43,2	0,72
	RB 12025		180	25	148,7	2	3,5	2	133	164	66,9	100	2,62
130	RB 13015	130	160	15	144,5	1	3,5	1,6	137	152	25	46,7	0,72
	RB 13025		190	25	158	2	3,5	2	143	174	69,5	107	2,82
140	RB 14016	140	175	16	154,8	1,5	2,5	1,6	147	162	25,9	50,1	1
	RB 14025		200	25	168	2	3,5	2	154	185	74,8	121	2,96
150	RB 15013	150	180	13	164	1	2,5	1,6	157	172	27	53,5	0,68
	RB 15025		210	25	178	2	3,5	2	164	194	76,8	128	3,16
	RB 15030		230	30	188	2	4,5	3	173	211	100	156	5,3
160	RB 16025	160	220	25	188,6	2	3,5	2	173	204	81,7	135	3,14
170	RB 17020	170	220	20	191	2	3,5	1,6	184	198	29	62,1	2,21
180	RB 18025	180	240	25	210	2	3,5	2	195	225	84	143	3,44
190	RB 19025	190	240	25	211,9	1,5	3,5	1,6	202	222	41,7	82,9	2,99
200	RB 20025	200	260	25	230	2,5	3,5	2	215	245	84,2	157	4
	RB 20030		280	30	240	2,5	4,5	3	221	258	114	200	6,7
	RB 20035		295	35	247,7	2,5	5	3	225	270	151	252	9,6
220	RB 22025	220	280	25	250,1	2,5	3,5	2	235	265	92,3	171	4,1

Diámetro eje Shaft diameter	Código Code	Dimensiones Dimensions					Orificios engrasadores Greasing holes		Diámetro apoyos Housing diameter		Coeficiente de carga Basic load rating		Peso Weight [Kg]
		d [mm]	D [mm]	B [mm]	Dp [mm]	(rpm)	a [mm]	b [mm]	ds [mm]	dh [mm]	C [KN]	Co [KN]	
240	RB 24025	240	300	25	269	3	3,5	2	256	281	68,3	145	4,5
250	RB 25025	250	310	25	277,5	3	3,5	2	265	290	69,3	150	5
	RB 25030		330	30	287,5	3	4,5	3	269	306	126	224	8,1
	RB 25040		355	40	300,7	3	6	3,5	275	326	195	348	14,8
300	RB 30025	300	360	25	328	3	3,5	2	315	340	76,3	178	5,9
	RB 30035		395	35	345	3	5	3	322	368	183	367	13,4
	RB 30040		405	40	351,6	3	6	3,5	326	377	212	409	17,2
350	RB 35020	350	400	20	373,4	3	3,5	1,6	363	383	54,1	143	3,9
400	RB 40035	400	480	35	440,3	3,5	5	3	422	459	156	370	14,5
	RB 40040		510	40	453,4	3,5	6	3,5	428	479	241	531	23,5
450	RB 45025	450	500	25	474	1,5	3,5	1,6	464	484	61,7	182	6,6
500	RB 50025	500	550	25	524,2	1,5	3,5	1,6	514	534	65,5	201	7,3
	RB 50040		600	40	548,8	3,5	6	3	526	572	239	607	26
	RB 50050		625	50	561,6	3,5	6	3,5	536	587	267	653	41,7
600	RB 60040	600	700	40	650	4	6	3	627	673	264	721	29
700	RB 70045	700	815	45	753,5	4	6	3	731	777	281	836	46
800	RB 80070	800	950	70	868,1	5	6	4	836	900	468	1330	105
900	RB 90070	900	1050	70	969	5	6	4	937	1001	494	1490	120
1000	RB 1000110	1000	1250	110	1114	6	6	6	1057	1171	1220	3220	360
1250	RB 1250110	1250	1500	110	1365,8	6	6	4	1308	1423	1350	3970	440

Ejemplo de denominación completa válida para serie RB / Designation example valid for RB series

1
2
3
4

RB 12025 -
 UU -
 CC0 -
 P5

1 Código en tabla / Code on table

2 Símbolo para la obturación / Sealing symbol

Sin símbolo: ninguna obturación / No symbol: without sealing

UU: obturación en ambos lados / sealing on both sides

U: obturación de un lado / sealing on one side only

3 Símbolo para los juegos / Clearances symbol

CC0: juego negativo (pre-carga) / negative clearances (preload)

C0: juego positivo / positive clearances

C1: juego positivo (mayor que C0) / positive clearances (more than C0)

4 Símbolo para la clase de precisión / Precision class symbol

Sin símbolo: clase estándar P0 / no symbol: standard precision class P0

P2: oscilación radial y axial y tolerancias clase 2 / radial and axial run-out and tolerances class 2

P4: oscilación radial y axial y tolerancias clase 4 / radial and axial run-out and tolerances class 4

P5: oscilación radial y axial y tolerancias clase 5 / radial and axial run-out and tolerances class 5

P6: oscilación radial y axial y tolerancias clase 6 / radial and axial run-out and tolerances class 6

USP: oscilación radial y axial USP / radial and axial run-out class USP

**FACILITAR LA DENOMINACION COMPLETA PARA RECIBIR DETALLES DE FABRICACION Y PRECISION.
SUBMIT THE REQUEST WITH COMPLETE DESIGNATION TO RECEIVE CONSTRUCTION AND PRECISION DETAILS.**

RE

SERIE DE PRECISI3N DE RODILLOS CRUZADOS

CROSSED ROLLER PRECISION SERIES

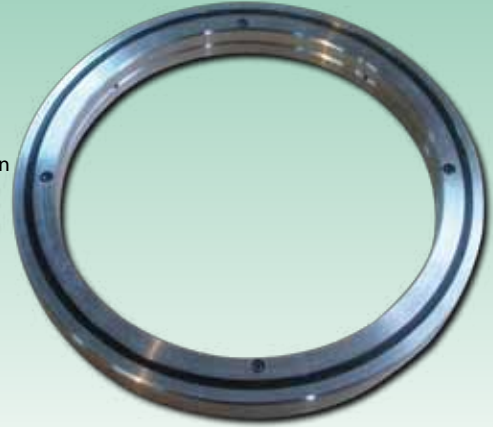
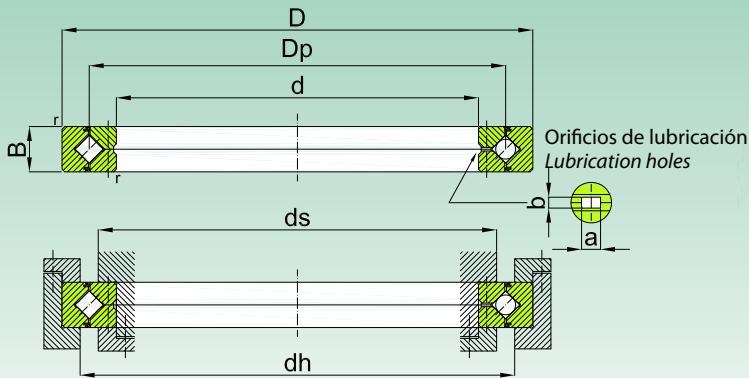

Diámetro eje Shaft diameter	Código Code	Dimensiones Dimensions					Orificios engrasadores Greasing holes		Diámetro apoyos Housing diameter		Coeficiente de carga Basic load rating		Peso Weight
		d [mm]	D [mm]	B [mm]	Dp [mm]	(rpm)	a [mm]	b [mm]	ds [mm]	dh [mm]	C [KN]	Co [KN]	
50	RE 5013	50	80	13	66	1	2,5	1,6	57,5	72	16,7	20,9	0,27
60	RE 6013	60	90	13	76	1	2,5	1,6	68	82	18	24,3	0,3
70	RE 7013	70	100	13	86	1	2,5	1,6	78	92	19,4	27,7	0,35
80	RE 8016	80	120	16	101,4	1	3	1,6	91	111	30,1	42,1	0,7
90	RE 9016	90	130	16	112	1,5	3	1,6	98	118	31,4	45,3	0,75
100	RE 10016	100	140	16	121,1	1,5	3	1,6	109	129	31,7	48,6	0,83
	RE 10020		150	20	127	1,5	3,5	1,6	113	133	33,1	50,9	1,45
110	RE 11012	110	135	12	123,3	1	2,5	1	117	127	12,5	24,1	0,4
	RE 11015		145	15	129	1	3	1,6	122	136	23,7	41,5	0,75
	RE 11020		160	20	137	1,5	3,5	1,6	120	140	34	54	1,56
120	RE 12016	120	150	16	136	1	3	1,6	127	141	24,2	43,2	0,72
	RE 12025		180	25	152	2	3,5	2	133	164	66,9	100	2,62
130	RE 13015	130	160	15	146	1	3	1,6	137	152	25	46,7	0,72
	RE 13025		190	25	162	2	3,5	2	143	174	69,5	107	2,82
140	RE 14016	140	175	16	160	1,5	3	1,6	147	162	25,9	50,1	1
	RE 14025		200	25	172	2	3,5	2	154	185	74,8	121	2,96
150	RE 15013	150	180	13	166	1	2,5	1,6	158	172	27	53,5	0,68
	RE 15025		210	25	182	2	3,5	2	164	194	76,8	128	3,16
	RE 15030		230	30	192	2	4,5	3	173	210	100	156	5,3
160	RE 16025	160	220	25	192	2	3,5	2	173	204	81,7	135	3,14
170	RE 17020	170	220	20	196,1	2	3,5	1,6	184	198	29	62,1	2,21
180	RE 18025	180	240	25	210	2	3,5	2	195	225	84	143	3,44
190	RE 19025	190	240	25	219	1,5	3,5	1,6	202	222	41,7	82,9	2,99
200	RE 20025	200	260	25	230	2,5	3,5	2	215	245	84,2	157	4
	RE 20030		280	30	240	2,5	4,5	3	221	258	114	200	6,7
	RE 20035		295	35	247,7	2,5	5	3	225	270	151	252	9,6
220	RE 22025	220	280	25	250,1	2,5	3,5	2	235	265	92,3	171	4,1

Diámetro eje Shaft diameter	Código Code	Dimensiones Dimensions					Orificios engrasadores Greasing holes		Diámetro apoyos Housing diameter		Coeficiente de carga Basic load rating		Peso Weight
		d [mm]	D [mm]	B [mm]	Dp [mm]	(rpm)	a [mm]	b [mm]	ds [mm]	dh [mm]	C [KN]	Co [KN]	
240	RE 24025	240	300	25	272,5	3	3,5	2	256	281	68,3	145	4,5
250	RE 25025	250	310	25	280,9	3	3,5	2	268	293	69,3	150	5
	RE 25030		330	30	287,5	3	4,5	3	269	306	126	244	8,1
	RE 25040		355	40	300,7	3	6	3,5	275	326	195	348	14,8
300	RE 30025	300	360	25	332	3	3,5	2	319	344	75,7	178	5,9
	RE 30035		395	35	345	3	5	3	322	368	183	367	13,4
	RE 30040		405	40	351,6	3	6	3,5	326	377	212	409	17,2
350	RE 35020	350	400	20	376,6	3	3,5	1,6	363	383	54,1	143	3,9
400	RE 40035	400	480	35	440,3	3,5	5	3	422	459	156	370	14,5
	RE 40040		510	40	453,4	3,5	6	3,5	428	479	241	531	23,5
450	RE 45025	450	500	25	476,6	1,5	3,5	1,6	464	484	61,7	182	6,6
500	RE 50025	500	550	25	526,6	1,5	3,5	1,6	514	534	65,5	201	7,3
	RE 50040		600	40	548,8	3,5	6	3	526	572	239	607	26
	RE 50050		625	50	561,6	3,5	6	3,5	536	587	267	653	41,7
600	RE 60040	600	700	40	650	4	6	3	627	673	264	721	29

Ejemplo de denominación completa válida para serie RE y RU / Designation example valid for RE and RU series

1
2
3
4
5
RE 14025 - UU - CC0 - P5 - B

1 Código en tabla / Code on table

2 Símbolo para la obturación / Sealing symbol

Sin símbolo: ninguna obturación / No symbol: without sealing

UU: obturación en ambos lados / sealing on both sides

U: obturación de un lado / sealing on one side only

Sólo para RU / Only for RU

UT: obturación en un lado sólo (lado opuesto fresados aro exterior) / one sealing opposite to countersunk holes side of outer ring

3 Símbolo para los juegos / Clearances symbol

CC0: juego negativo (pre-carga) / negative clearances (preload)

C0: juego positivo / positive clearances

C1: juego positivo (mayor que C0) / positive clearances (more than C0)

4 Símbolo para la clase de precisión / Precision class symbol

Sin símbolo: clase estándar P0 (P5 para RU) / no symbol: standard precision class P0 (P5 for RU)

P2: oscilación radial y axial y tolerancias clase 2 / radial and axial run-out and tolerances class 2

P4: oscilación radial y axial y tolerancias clase 4 / radial and axial run-out and tolerances class 4

P5: oscilación radial y axial y tolerancias clase 5 / radial and axial run-out and tolerances class 5

P6: oscilación radial y axial y tolerancias clase 6 / radial and axial run-out and tolerances class 6

USP: oscilación radial y axial USP / radial and axial run-out class USP

5 Sólo para RU / Only for RU

Símbolo para la clase de precisión de oscilación relativa al aro giratorio / Symbol for ring precision reference

Sin símbolo: aro interior en rotación / No symbol: outer ring rotating

R: aro exterior en rotación / Outer ring rotating

B: aro interior y exterior con posibilidad de rotación / Outer and inner ring both rotating

**FACILITAR LA DENOMINACION COMPLETA PARA RECIBIR DETALLES DE FABRICACION Y PRECISION.
SUBMIT THE REQUEST WITH COMPLETE DESIGNATION TO RECEIVE CONSTRUCTION AND PRECISION DETAILS.**

RU

SERIE DE PRECISIÓN DE RODILLOS CRUZADOS

CROSSED ROLLER PRECISION SERIES

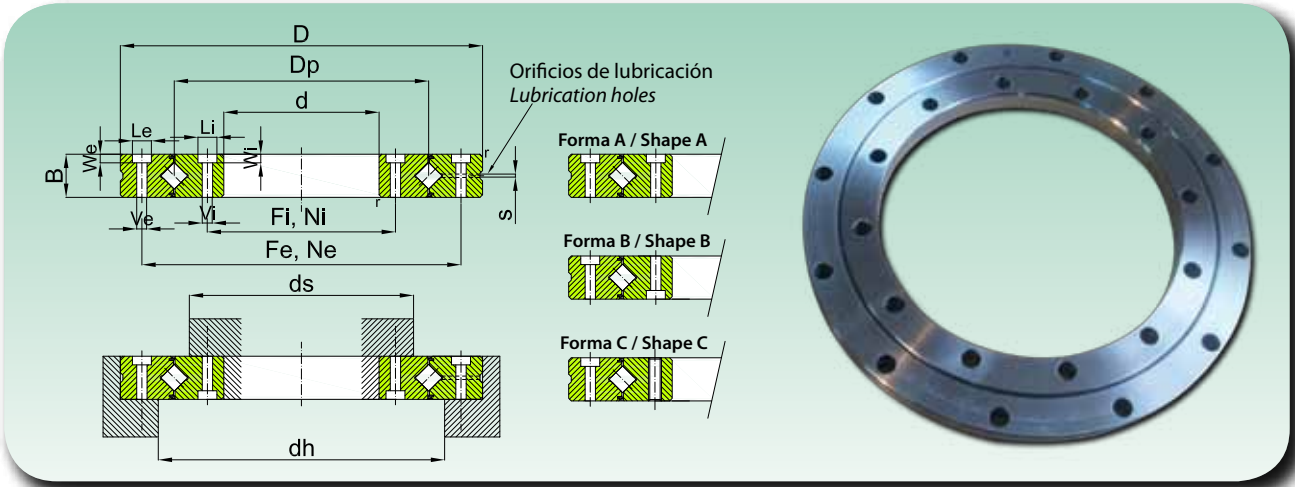

Ø Eje Ø Shaft	Código Code	Forma Shape	Dimensiones Dimensions							Orificios de fijación/Fixing holes										Ø Apoyos Ø Housing		Coef. de carga Basic load rating		Peso / Weight [Kg]
			d [mm]	D [mm]	B [mm]	Dp [mm]	(rpm)	s [mm]	Aro exterior Outer ring					Aro interior Inner ring					ds [mm]	dh [mm]	C [KN]	Co [KN]		
									Fe [mm]	Ne [mm]	Ve [mm]	Le [mm]	We [mm]	Fi [mm]	Ni [mm]	Vi [mm]	Li [mm]	Wi [mm]						
20	RU 42	A	20	70	12	41,5	0,6	3,1	57	6	Ø3,4	Ø6,5	3,3	28	6	M3	-	-	37	47	7,35	8,35	0,29	
35	RU 66	A	35	95	15	66	0,6	3,1	83	8	Ø4,5	Ø8	4,4	45	8	M4	-	-	59	74	17,5	22,3	0,62	
55	RU 85	A	55	120	15	85	0,6	3,1	105	8	Ø5,5	Ø9,5	5,4	65		M5	-	-	79	93	20,3	29,5	1	
80	RU 124	C	80	165	22	124	1	3,1	148	10	Ø5,5	Ø9,5	5,4	97	10	Ø5,5	Ø9,5	5,4	114	134	33,1	50,9	2,6	
	RU 124G	B														M5	-	-						
	RU 124X	A																						
90	RU 148	C	90	210	25	147,5	1,5	3,1	187	12	Ø9	Ø14	8,6	112	12	Ø9	Ø14	8,6	133	162	49,1	76,8	4,9	
	RU 148G	B														M8	-	-						
	RU 148X	A																						
115	RU 178	C	115	240	28	178	1,5	3,1	217	12	Ø9	Ø14	8,6	139	12	Ø9	Ø14	8,6	161	195	80,3	135	6,8	
	RU 178G	B														M8	-	-						
	RU 178X	A																						
160	RU 228	C	160	295	35	227,5	2	6	270	12	Ø11	Ø17,5	10,8	184	12	Ø11	Ø17,5	10,8	208	246	104	172	11,4	
	RU 228G	B														M10	-	-						
	RU 228X	A																						
210	RU 297	C	210	380	40	297,3	2,5	6	350	16	Ø14	Ø20	13	240	16	Ø14	Ø20	13	272	320	156	281	21,3	
	RU 297G	B														M12	-	-						
	RU 297X	A																						
350	RU 445	C	350	540	45	445,4	2,5	6	505	24	Ø14	Ø20	13	385	24	Ø14	Ø20	13	417	473	222	473	35,4	
	RU 445G	B														M12	-	-						
	RU 445X	A																						

VÉASE DESIGNACIÓN PÁG. 147 - CHECK DESIGNATION PAG.147

FACILITAR LA DENOMINACION COMPLETA PARA RECIBIR DETALLES DE FABRICACION Y PRECISION.
SUBMIT THE REQUEST WITH COMPLETE DESIGNATION TO RECEIVE CONSTRUCTION AND PRECISION DETAILS.

CRBH

SERIE DE PRECISIÓN DE RODILLOS CRUZADOS

CROSSED ROLLER PRECISION SERIES

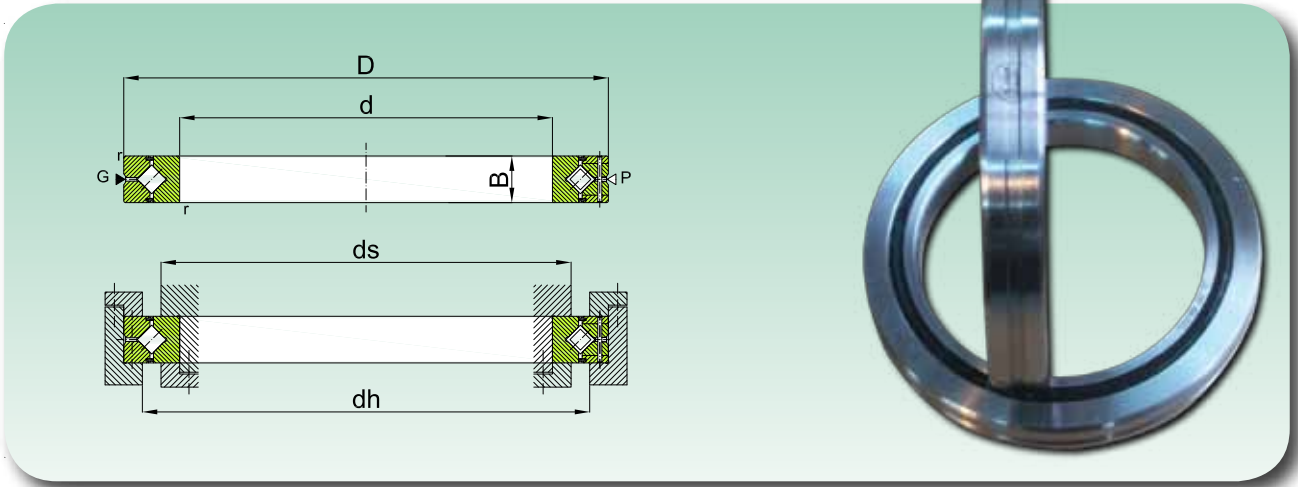

Diámetro eje Shaft diameter	Código/Code	Dimensiones Dimensions				Diámetro apoyos Housing diameter		Coef. de carga Basic load rating		Peso Weight
		d [mm]	D [mm]	B [mm]	(rpm) min	ds [mm]	dh [mm]	C [KN]	Co [KN]	
50	CRBH 5013 A	50	80	13	0.6	56	74	17,3	20,9	0.29
60	CRBH 6013 A	60	90	13	0.6	66	84	18,8	24,3	0.33
70	CRBH 7013 A	70	100	13	0.6	76	94	20,1	27,7	0.38
80	CRBH 8016 A	80	120	16	0.6	88	112	32,1	43,4	0.74
90	CRBH 9016 A	90	130	16	0.6	98	122	33,1	46,8	0.81
100	CRBH 10020 A	100	150	20	0.6	110	140	50,9	72,2	1.45
110	CRBH 11020 A	110	160	20	0.6	120	150	52,4	77,4	1.56
120	CRBH 12025 A	120	180	25	1	132	168	73,4	108,0	2.62
130	CRBH 13025 A	130	190	25	1	142	178	75,9	115,0	2.82
140	CRBH 14025 A	140	200	25	1	152	188	81,9	130,0	2.96
150	CRBH 15025 A	150	210	25	1	162	198	84,3	138,0	3.16
200	CRBH 20025 A	200	260	25	1	212	248	92,3	169,0	4
250	CRBH 25025 A	250	310	25	1.5	262	298	102,0	207,0	4.97

Ejemplo de denominación completa válida para serie CRBH / Designation example valid for CRBH series

1 2 3 4

CRBH 25025 A - UU - T1 - P5

- 1 Código en tabla / Code on table
- 2 Símbolo para la obturación / Sealing symbol
Sin símbolo: ninguna obturación / No symbol: without sealing
UU: obturación en ambos lados / sealing on both sides
U: obturación de un lado / sealing on one side only
- 3 Símbolo para los juegos / Clearances symbol
T1: juego negativo (pre-carga) / negative clearances (preload)
C1: juego positivo / positive clearances
C2: juego positivo (mayor que C0) / positive clearances (more than C0)

- 4 Símbolo para la clase de precisión/ Precision class symbol
P2: oscilación radial y axial y tolerancias clase 2
radial and axial run-out and tolerances class 2
P4: oscilación radial y axial y tolerancias clase 4
radial and axial run-out and tolerances class 4
P5: oscilación radial y axial y tolerancias clase 5
radial and axial run-out and tolerances class 5
P6: oscilación radial y axial y tolerancias clase 6
radial and axial run-out and tolerances class 6

**FACILITAR LA DENOMINACION COMPLETA PARA RECIBIR DETALLES DE FABRICACION Y PRECISION.
SUBMIT THE REQUEST WITH COMPLETE DESIGNATION TO RECEIVE CONSTRUCTION AND PRECISION DETAILS.**

CRBC - CRB

SERIE DE PRECISIÓN DE RODILLOS CRUZADOS

CROSSED ROLLER PRECISION SERIES

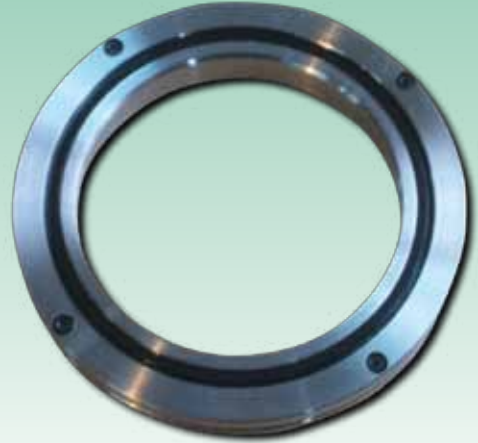
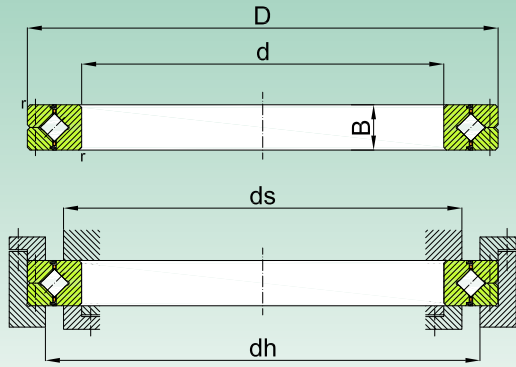

Diámetro eje Shaft diameter	Código/Code		Dimensiones				Diámetro apoyos		CRBC		CRB		Peso Weight
			Dimensions				Housing diameter		Coef. carga		Coef. carga		
	Con jaula With cage	Llenado pleno Full complement	d [mm]	D [mm]	B [mm]	(rpm)	ds [mm]	dh [mm]	C [KN]	Co [KN]	C [KN]	Co [KN]	
50	CRBC 5013	CRB 5013	50	80	13	0.6	55	71	10,7	12,6	14,2	18,4	0.29
60	CRBC 6013	CRB 6013	60	90	13	0.6	64	81	11,6	14,6	15,4	21,5	0.33
70	CRBC 7013	CRB 7013	70	100	13	0.6	75	91	12,3	16,7	17,0	25,5	0.38
80	CRBC 8016	CRB 8016	80	120	16	0.6	86	107	18,2	25,5	24,3	37,5	0.74
90	CRBC 9016	CRB 9016	90	130	16	1	98	118	19,4	28,6	25,9	42,1	0.81
100	CRBC 10020	CRB 10020	100	150	20	1	108	134	31,5	45,1	39,4	61,1	1.45
110	CRBC 11020	CRB 11020	110	160	20	1	118	144	33,5	50,7	41,2	66,7	1.56
120	CRBC 12025	CRB 12025	120	180	25	1.5	132	164	47,7	70,5	59,9	95,4	2.62
130	CRBC 13025	CRB 13025	130	190	25	1.5	140	172	49,2	74,8	61,0	99,8	2.82
140	CRBC 14025	CRB 14025	140	200	25	1.5	151	183	50,7	79,2	64,1	108,0	2.96
150	CRBC 15025	CRB 15025	150	210	25	1.5	160	192	53,8	87,7	65,0	113,0	3.16
	CRBC 15030	CRB 15030	150	230	30	1.5	166	202	69,2	108,0	85,9	144,0	5.3
200	CRBC 20025	CRB 20025	200	260	25	2	208	239	60,2	110,0	75,3	148,0	4
	CRBC 20030	CRB 20030	200	280	30	2	218	262	108,0	178,0	133,0	234,0	6.7
	CRBC 20035	CRB 20035	200	295	35	2	221	274	137,0	215,0	168,0	282,0	9.58
250	CRBC 25025	CRB 25025	250	310	25	2.5	259	290	67,2	136,0	83,9	183,0	4.97
	CRBC 25030	CRB 25030	250	330	30	2.5	265	310	116,0	208,0	146,0	283,0	8.1
	CRBC 25040	CRB 25040	250	355	40	2.5	271	330	179,0	299,0	215,0	382,0	14.8
300	CRBC 30025	CRB 30025	300	360	25	2.5	310	341	73,8	162,0	91,9	217,0	5.88
	CRBC 30035	CRB 30035	300	395	35	2.5	318	372	163,0	299,0	205,0	408,0	13.4
	CRBC 30040	CRB 30040	300	405	40	2.5	321	381	194,0	351,0	235,0	451,0	17.2
400	CRBC 40035	CRB 40035	400	480	35	2.5	414	457	133,0	300,0	165,0	400,0	14.5
	CRBC 40040	CRB 40040	400	510	40	2.5	423	483	222,0	455,0	270,0	590,0	23.5
	CRBC 40070	CRB 40070	400	580	70	2.5	430	532	470,0	811,0	576,0	1060,0	72.4

Diámetro eje Shaft diameter	Código/Code		Dimensiones Dimensions				Diámetro apoyos Housing diameter		CRBC		CRB		Peso Weight
			d	D	B	(rpm)	ds	dh	Coef. carga Basic load rating		Coef. carga Basic load rating		
	Con jaula With cage	Llenado pleno Full complement	[mm]	[mm]	[mm]	[mm]	[mm]	[mm]	[KN]	[KN]	[KN]	[KN]	
400	CRBC 40035	CRB 40035	400	480	35	2.5	414	457	133,0	300,0	165,0	400,0	14.5
	CRBC 40040	CRB 40040	400	510	40	2.5	423	483	222,0	455,0	270,0	590,0	23.5
	CRBC 40070	CRB 40070	400	580	70	2.5	430	532	470,0	811,0	576,0	1060,0	72.4
500	CRBC 50040	CRB 50040	500	600	40	2.5	517	573	212,0	497,0	259,0	648,0	26
	CRBC 50050	CRB 50050	500	625	50	2.5	531	592	247,0	561,0	306,0	747,0	41.7
	CRBC 50070	CRB 50070	500	680	70	2.5	530	633	536,0	1020,0	653,0	1330,0	86.1
600	CRBC 60040	CRB 60040	600	700	40	3	621	676	231,0	581,0	287,0	774,0	30.6
	CRBC 60070	CRB 60070	600	780	70	3	630	734	591,0	1230,0	700,0	1540,0	102
	CRBC 600120	CRB 600120	600	870	120	3	643	817	1250,0	2210,0	1490,0	2800,0	274
700	CRBC 70045	CRB 70045	700	815	45	3	730	785	250,0	681,0	313,0	917,0	46.5
	CRBC 70070	CRB 70070	700	880	70	3	731	834	630,0	1390,0	766,0	1810,0	115
	CRBC 700150	CRB 700150	700	1020	150	3	751	953	1660,0	3010,0	1980,0	3820,0	478
800	CRBC 80070	CRB 80070	800	950	70	4	831	907	417,0	1090,0	513,0	1440,0	109
	CRBC 800100	CRB 800100	800	1030	100	4	840	972	936,0	2040,0	1140,0	2640,0	247

Ejemplo de denominación completa válida para serie CRB(C) / Designation example valid for CRB(C) series

1
2
3
4
CRBC 12025 - UU - T1 - P5

1 Código en tabla / Code on table

2 Símbolo para la obturación / Sealing symbol

Sin símbolo: ninguna obturación / No symbol: without sealing

UU: obturación en ambos lados / sealing on both sides

U: obturación de un lado / sealing on one side only

3 Símbolo para los juegos / Clearances symbol

T1: juego negativo (pre-carga) / negative clearances (preload)

C1: juego positivo / positive clearances

C2: juego positivo (mayor que C0) / positive clearances (more than C0)

4 Símbolo para la clase de precisión / Precision class symbol

P2: oscilación radial y axial y tolerancias clase 2 / radial and axial run-out and tolerances class 2

P4: oscilación radial y axial y tolerancias clase 4 / radial and axial run-out and tolerances class 4

P5: oscilación radial y axial y tolerancias clase 5 / radial and axial run-out and tolerances class 5

P6: oscilación radial y axial y tolerancias clase 6 / radial and axial run-out and tolerances class 6

**FACILITAR LA DENOMINACION COMPLETA PARA RECIBIR DETALLES DE FABRICACION Y PRECISION.
SUBMIT THE REQUEST WITH COMPLETE DESIGNATION TO RECEIVE CONSTRUCTION AND PRECISION DETAILS.**

SX

SERIE DE PRECISIÓN DE RODILLOS CRUZADOS

CROSSED ROLLER PRECISION SERIES

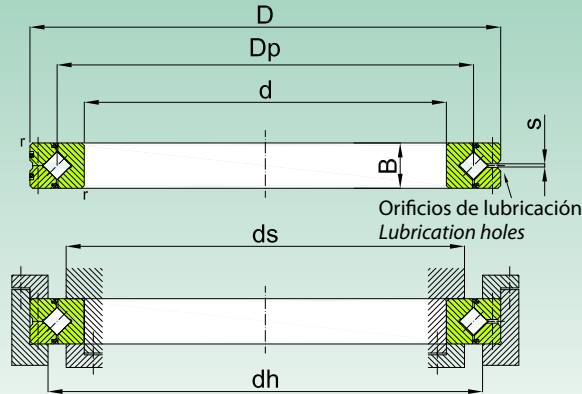

Diámetro eje Shaft diameter	Código Code	Dimensiones Dimensions						Diámetro apoyos Housing diameter		Coef. carga axial Axial load rating		Coef. carga radial Radial load rating		Peso Weight
		d [mm]	D [mm]	B [mm]	Dp [mm]	(rpm)	s [mm]	ds [mm]	dh [mm]	C kN	Co kN	Cr kN	Cor kN	
70	SX 011814	70	90	10	80	0,6	1,2	79,5	80,5	18	60	12	30	0,3
90	SX 011818	90	115	13	102	1	1,2	101,5	102,5	26	96	17	47	0,4
100	SX 011820	100	125	13	112	1	1,2	111,5	112,5	28	106	18	52	0,5
120	SX 011824	120	150	16	135	1	1,5	134,4	135,6	41	153	26	75	0,8
140	SX 011828	140	175	18	157	1,1	1,5	156,3	157,7	64	237	41	116	1,1
160	SX 011832	160	200	20	180	1,1	1,5	179,2	180,8	69	272	44	133	1,7
180	SX 011836	180	225	22	202	1,1	2	201,2	202,8	98	381	63	187	2,3
200	SX 011840	200	250	24	225	1,5	2	224,2	225,8	106	425	68	208	3,1
240	SX 011848	240	300	28	270	2	2	269,2	270,8	149	612	95	300	5,3
300	SX 011860	300	380	38	340	2,1	2,5	339,2	340,8	245	1027	156	504	12
340	SX 011868	340	420	38	380	2,1	2,5	379,2	380,8	265	1148	167	563	13,5
400	SX 011880	400	500	46	450	2,5	2,5	449	451	385	1699	244	833	24
500	SX 0118/500	500	620	56	560	3	2,5	558,8	561,2	560	2538	355	1244	44

Ejemplo de denominación completa válida para serie SX / Designation example valid for SX series

1 2

SX 011814 - RLO

1 Código en tabla / Code on table

2 Símbolo para los juegos / Clearances symbol

USP: juego negativo (pre-carga) / negative clearances (preload)

RLO: juego positivo / positive clearances

FACILITAR LA DENOMINACION COMPLETA PARA RECIBIR DETALLES DE FABRICACION Y PRECISION.
SUBMIT THE REQUEST WITH COMPLETE DESIGNATION TO RECEIVE CONSTRUCTION AND PRECISION DETAILS.



Rodamientos de precisión YRT, para mesas giratorias

Turntable precision bearing YRT

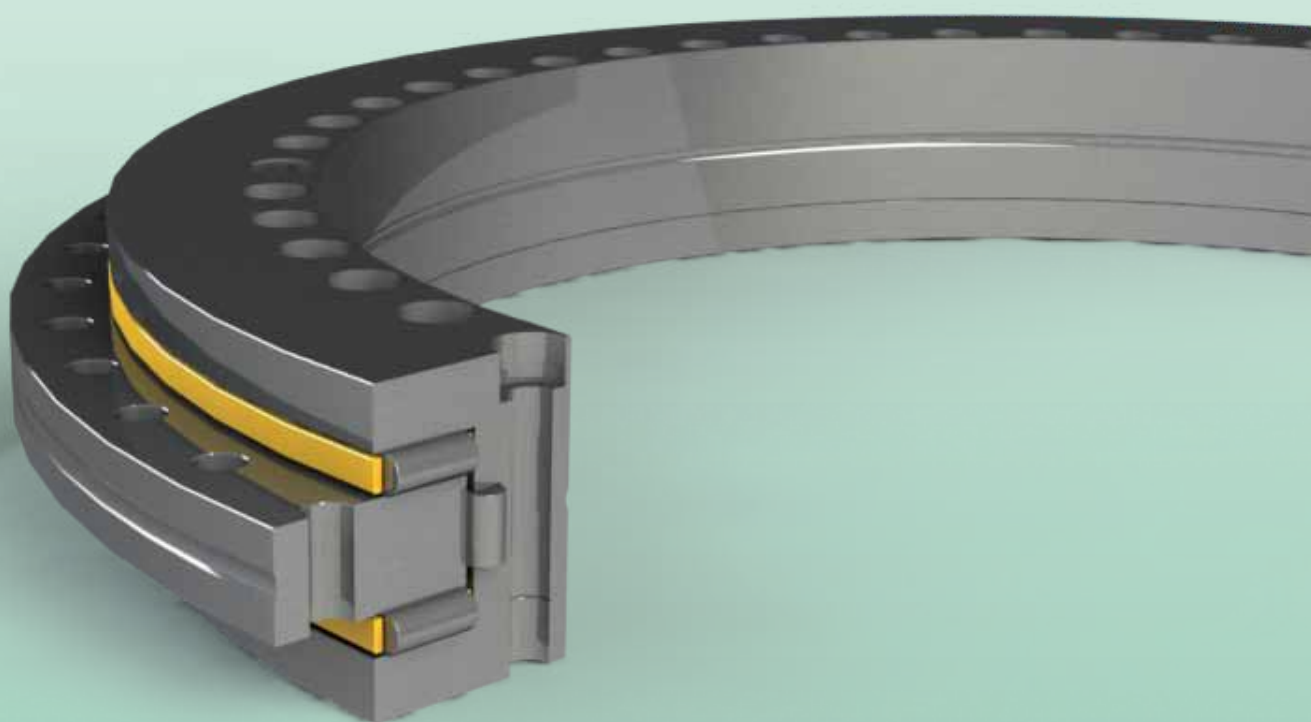

YRT/YRTS/ZKLDF SERIES

YRT

SERIE PARA VELOCIDADES DE ROTACIÓN ESTÁNDAR

STANDARD ROTATING SPEED SERIES

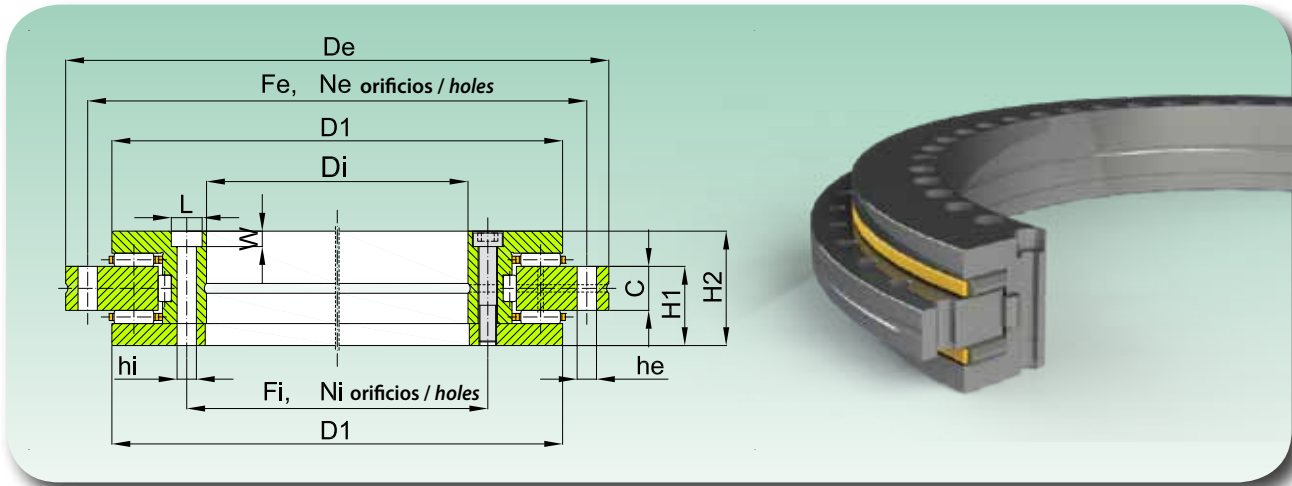

Código Code	Dimensiones Dimensions						Orificios de fijación Fixing Holes						Oscilación Radial y Axial Radial Run-Out		
	De	D1	Di	C	H1	H2	Fe	Ne	he	fi	Ni	hi		L	W
	[mm]	[mm]	[mm]	[mm]	[mm]	[mm]	[mm]	[-]	[mm]	[mm]	[-]	[mm]		[mm]	[mm]
YRT 50	126 -0,011	105	50 -0,008	10	20 ±0,125	30	116	12	5,6	63	10	5,6	-	-	2
YRT 80	146 -0,011	130	80 -0,09	12	23,35 ±0,15	35	138	12	4,6	92	10	5,6	10	4	3
YRT 100	185 -0,015	160	100 -0,010	12	25 ±0,175	38	170	15	5,6	112	16	5,6	10	5,4	3
YRT 120	210 -0,015	184	120 -0,010	12	26 ±0,175	40	195	21	7	135	22	7	11	6,2	3
YRT 150	240 -0,015	214	150 -0,013	12	26 ±0,175	40	225	33	7	165	34	7	11	6,2	3
YRT 180	280 -0,018	244	180 -0,013	15	29 ±0,175	43	260	45	7	194	46	7	11	6,2	4
YRT 200	300 -0,018	274	200 -0,015	15	30 ±0,175	45	285	45	7	215	46	7	11	6,2	4
YRT 260	385 -0,020	345	260 -0,018	18	36,5 ±0,20	55	365	33	9,3	280	34	9,3	15	8,2	6
YRT 325	450 -0,023	415	325 -0,023	20	40 ±0,20	60	430	33	9,3	342	34	9,3	15	8,2	6
YRT 395	525 -0,028	486	395 -0,023	20	42,5 ±0,20	65	505	45	9,3	415	46	9,3	15	8,2	6
YRT 460	600 -0,028	560	460 -0,023	22	46 ±0,225	70	580	45	9,3	482	46	9,3	15	8,2	6
YRT 580	750 -0,035	700	580 -0,025	30	60 ±0,25	90	720	42	11,4	610	46	11,4	18	11	10
YRT 650	870 -0,050	800	650 -0,038	34	78 ±0,25	122	830	42	14	680	46	14	20	13	10
YRT 850	1095 -0,063	1018	850 -0,050	37	80,5 ±0,30	124	1055	54	18	890	58	18	26	17	12
YRT 950	1200 -0,063	1130	950 -0,050	40	86 ±0,30	132	1160	54	18	990	58	18	26	17	12
YRT 1030	1800 -0,080	1215	1030 -0,072	40	92,5 ±0,40	145	1255	66	18	1075	60	18	26	17	15

- Rodamiento levemente precargado
- El rodamiento requiere una elevada calidad de las superficies de contacto para funcionar perfectamente
- La fuerza de fricción dinámica ha sido ensayada a una velocidad de 5 rpm. La fuerza de fricción estática debe ser de 2-2,5 veces la fuerza de fricción dinámica
- El par de apriete se deberá aplicar en tres pasadas, al 40-70-100% del dato presente en la tabla, siguiendo una secuencia de apriete en cruz

- Slightly preloaded bearing
- The bearing requires an high quality of companion surfaces in order to work perfectly
- Dynamic frictional torque is tested at speed 5 r/min. Static frictional torque should be 2 - 2,5 times of dynamic frictional torque
- Tightening torque must be applied on 3 stages, at 40-70-100% of listed data, according crosswise tightening sequence

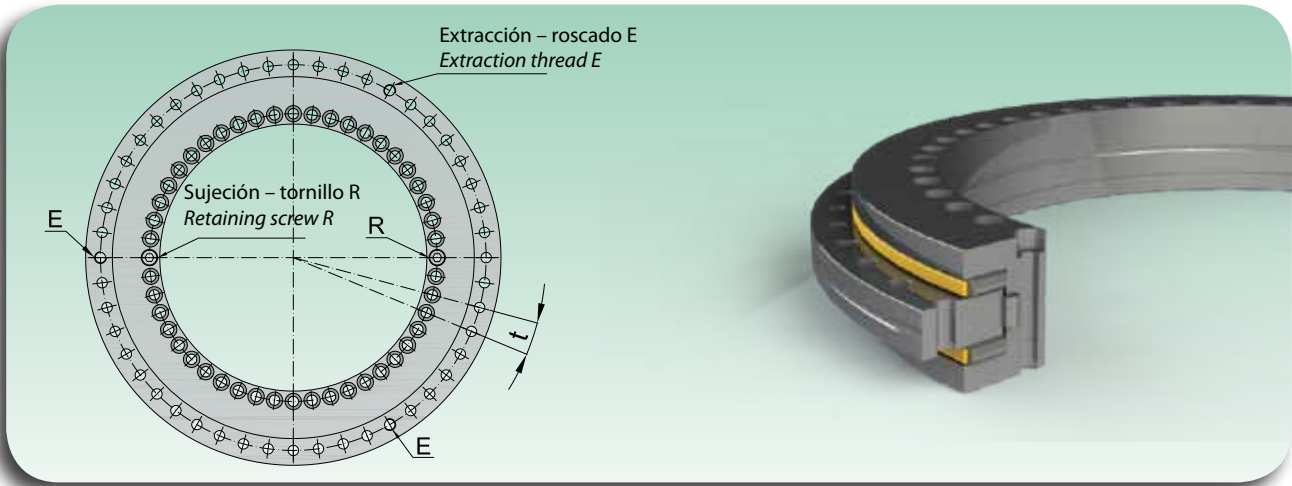

Código Code	Velocidad límite Limiting speed rpm	Fuerza de fricción dinámica Dynamic friction torque [Nm]	Coeficiente de carga Basic load rating				N. torn. de ensamblado Retaining screws n. R [-]	Orificios de extracción Extraction holes		Distancia de perforación Holes pitch [nxt°]	Par apriete tornillos Screw tightening torque [Nm]	Peso Weight [kg]
			Axial/Axial		Radial/Radial			Tipo Type [-]	Cantidad Quantity [-]			
			Ca	Coa	Cr	Cor						
YRT 50	440	2,5	38	158	28,5	49,5	2x180°	-	-	12 x 30°	8,5	1,6
YRT 80	530	3	56	255	42,5	100	2x180°	-	-	12 x 30°	8,5	2,4
YRT 100	430	3	75,5	415	47,5	120	2x180°	M5	3x120°	18 x 20°	8,5	4,1
YRT 120	340	7	102	540	52	143	2x180°	M8	3x120°	24 x 15°	14	5,3
YRT 150	320	10	112	630	56	170	2x180°	M8	3x120°	36 x 10°	14	6,2
YRT 180	280	12	118	710	69,5	200	2x180°	M8	3x120°	48 x 7,5°	14	7,7
YRT 200	260	14	120	765	81,5	220	2x180°	M8	3x120°	48 x 7,5°	14	9,7
YRT 260	200	20	160	1060	93	290	2x180°	M12	3x120°	36 x 10°	34	18,3
YRT 325	170	40	275	1930	120	345	2x180°	M12	3x120°	36 x 10°	34	25
YRT 395	140	55	300	2280	186	655	2x180°	M12	3x120°	48 x 7,5°	34	33
YRT 460	120	70	355	2800	200	765	2x180°	M12	3x120°	48 x 7,5°	34	45
YRT 580	80	140	490	4250	228	965	2x180°	M12	6x60°	48 x 7,5°	68	89
YRT 650	65	200	1040	8000	490	18000	2x180°	M12	6x60°	48 x 7,5°	116	170
YRT 850	50	300	1000	8650	455	1730	2x180°	M16	6x60°	60 x 6°	284	253
YRT 950	40	600	1290	11400	530	2040	2x180°	M16	6x60°	60 x 6°	284	312
YRT 1030	35	800	1380	12000	620	2650	12x30°	M16	6x60°	72 x 5°	284	375

**PARA CONSTRUCCIONES Y PRECISIONES DIFERENTES DE LAS ESTÁNDARES ELEVAR SOLICITUD ESPECÍFICA A NUESTRA OFICINA COMERCIAL.
FOR CONSTRUCTIONS AND PRECISION CLASS DIFFERENT FROM STANDARD TYPES PLEASE SEND SPECIFIC REQUEST TO OUR COMMERCIAL OFFICE.**

YRTS

SERIE PARA ALTA VELOCIDAD DE ROTACIÓN

HIGH ROTATION SPEED SERIES

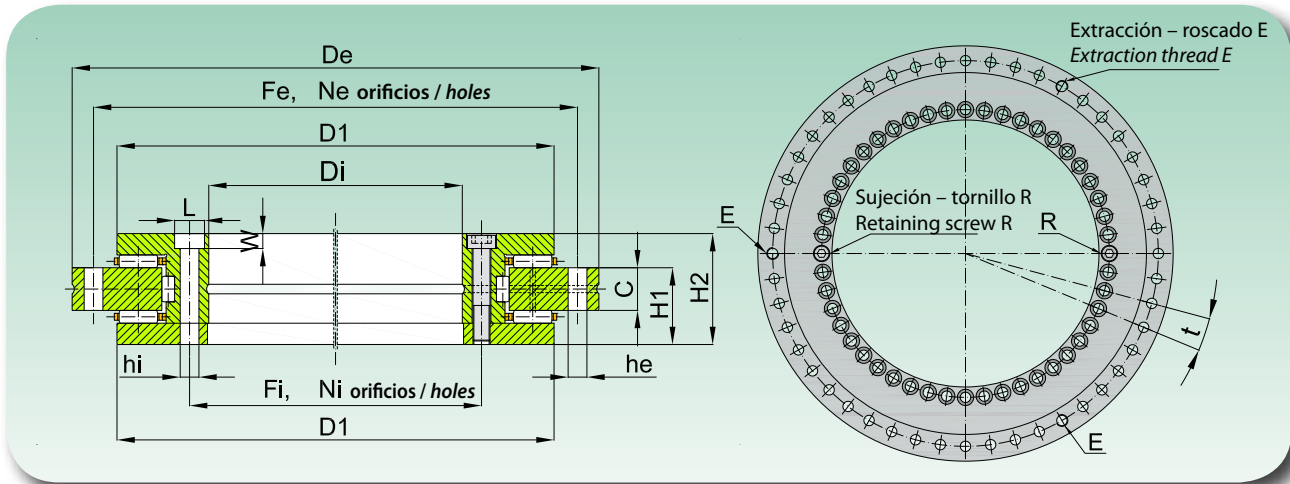

Código Code	Dimensiones/Dimensions						Orificios de fijación/Fixing Holes							Oscilación Radial y Axial Axial and Radial Run-Out [μm]	
	De	D1	Di	C	H1	H2	Fe	Ne	he	fi	Ni	hi	L		W
	[mm]	[mm]	[mm]	[mm]	[mm]	[mm]	[mm]	[-]	[mm]	[mm]	[-]	[mm]	[mm]		[mm]
YRTS 200	300 -0,018	274	200 -0,015	15	30 ±0,175	45	285	45	7	215	46	7	11	6,2	4
YRTS 260	385 -0,020	345	260 -0,018	18	36,5 ±0,20	55	365	33	9,3	280	34	9,3	15	8,2	6
YRTS 325	450 -0,023	415	325 -0,023	20	40 ±0,20	60	430	33	9,3	342	34	9,3	15	8,2	6
YRTS 395	525 -0,028	486	395 -0,023	20	42,5 ±0,20	65	505	45	9,3	415	46	9,3	15	8,2	6
YRTS 460	600 -0,028	560	460 -0,023	22	46 ±0,225	70	580	45	9,3	482	46	9,3	15	8,2	6

Código Code	Velocidad límite Limiting speed rpm	Fuerza de fricción dinámica Dynamic friction torque [Nm]	Coeficiente de carga Basic load rating				N. torn. de ensamblado Retaining screws n.R [-]	Orificios de extracción Extraction holes		Distancia de perforación Holes pitch [nXα°]	Par apriete tornillos Screw tightening torque [Nm]	Peso Weight [kg]
			Axial/Axial		Radial/Radial			Tipo Type	Cantidad Quantity			
			Ca	Coa	Cr	Cor		[-]	[-]			
YRTS 200	1160	-	155	840	94	226	2	M8	3	48 x 7,5°	14	9,7
YRTS 260	910	-	173	1050	110	305	2	M12	3	36 x 10°	34	18,3
YRTS 325	760	-	191	1260	109	320	2	M12	3	36 x 10°	34	25
YRTS 395	650	-	214	1540	121	390	2	M12	3	48 x 7,5°	34	33
YRTS 460	560	-	221	1690	168	570	2	M12	3	48 x 7,5°	34	45

- El par de apriete se deberá aplicar en tres pasadas, al 40-70-100% del dato presente en la tabla, siguiendo una secuencia de apriete en cruz
- El rodamiento requiere una elevada calidad de las superficies de contacto para funcionar perfectamente

- Tightening torque must be applied on 3 stages, at 40-70-100% of listed data, according crosswise tightening sequence
 - The bearing requires a high quality of companion surfaces in order to work perfectly

TOLERANCIAS DE ELABORACIÓN ALOJAMIENTO DE LOS YRT

YRT HOUSING AND SHAFT MACHINING TOLERANCES

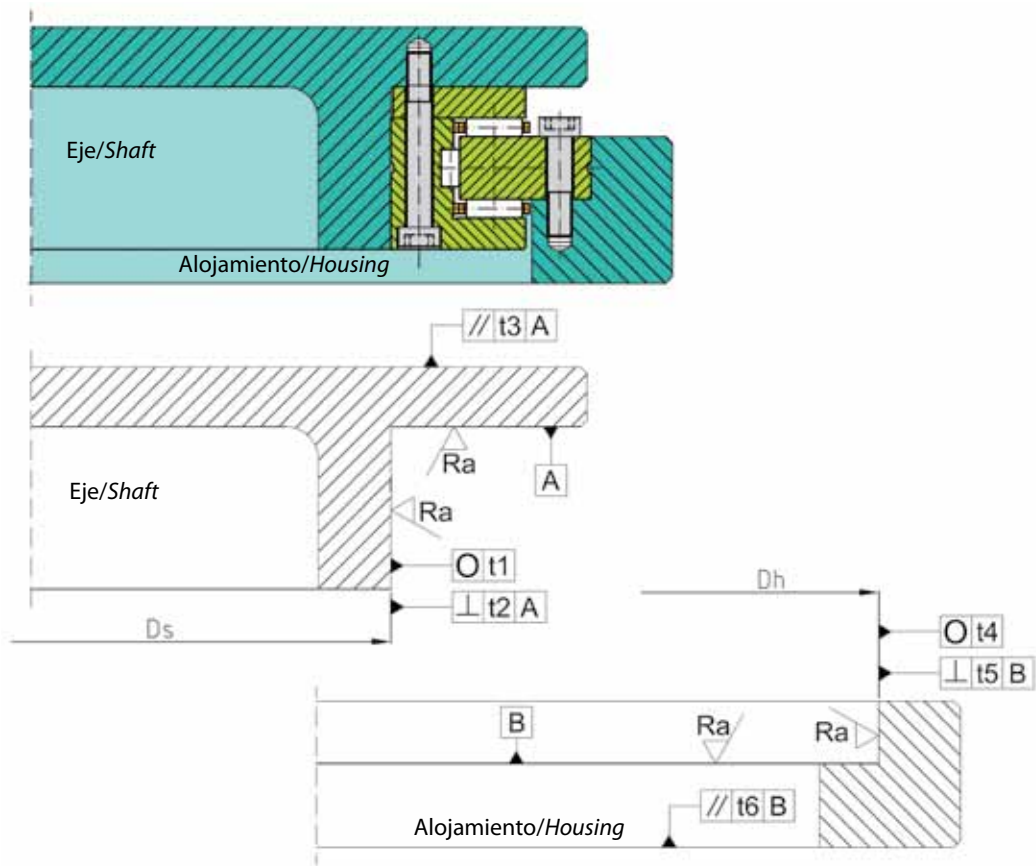

Código Code	Eje Shaft					Alojamiento Housing				
	D_s [mm]	t_1 [μm]	t_2 [μm]	t_3 [μm]	R_a [μm]	D_h [mm]	t_4 [μm]	t_5 [μm]	t_6 [μm]	R_a [μm]
YRT 50	50-0,011	4	3	3	0,4	126 +0,018/-0,007	8	5	5	0,8
YRT 80	80-0,0113	5	3	3	0,4	146 +0,018/-0,007	8	5	5	0,8
YRT 100	100-0,015	6	4	4	0,4	185 +0,022/-0,007	10	7	7	0,8
YRT 120	120-0,015	6	4	4	0,4	210 +0,022/-0,007	10	7	7	0,8
YRT 150	150-0,015	8	5	5	0,8	240 +0,022/-0,007	10	7	7	0,8
YRT 180	180-0,018	8	5	5	0,8	280 +0,025/-0,007	12	8	8	0,8
YRT/S 200	200-0,020	10	7	7	0,8	300 +0,025/-0,007	12	8	8	0,8
YRT/S 260	260-0,023	12	8	8	0,8	385 +0,029/-0,007	13	9	9	0,8
YRT/S 325	325-0,025	13	9	9	0,8	450 +0,033/-0,007	15	10	10	0,8
YRT/S 395	395-0,025	13	9	9	0,8	525 +0,034/-0,010	16	11	11	1,6
YRT/S 460	460-0,027	15	10	10	0,8	600 +0,034/-0,010	16	11	11	1,6
YRT 580	580-0,028	16	11	11	1,6	750 +0,038/-0,012	18	12	12	1,6
YRT 650	650-0,032	18	12	12	1,6	870 +0,044/-0,012	20	14	14	1,6
YRT 850	850-0,036	20	14	14	1,6	1095 +0,052/-0,014	24	16	16	1,6
YRT 950	950-0,036	20	14	14	1,6	1200 +0,052/-0,014	24	16	16	1,6
YRT 1030	1030-0,045	25	16	16	1,6	1300 +0,060/-0,016	27	18	18	1,6

Tabla de las tolerancias para eje y alojamiento ($1 \mu\text{m} = 0,001 \text{ mm}$)
 Tolerance table for shaft and housing ($1 \mu\text{m} = 0,001 \text{ mm}$)

ZKLDF

SERIE ESTÁNDAR

STANDARD SERIES

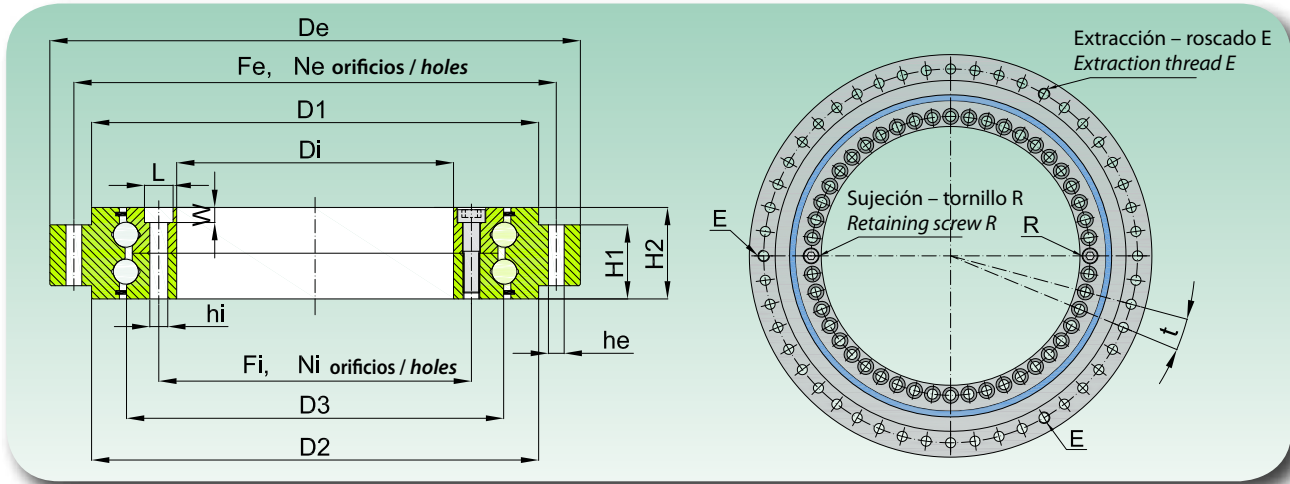

Código Code	Dimensiones/Dimensions								Orificios de fijación/Fixing holes								Oscilación Radial y Axial Axial and Radial Run-Out [μm]
	De	D1	D2	D3	Di	C	H1	H2	Fe	Ne	he	fi	Ni	hi	L	W	
	[mm]	[mm]	[mm]	[mm]	[mm]	[mm]	[mm]	[mm]	[mm]	[-]	[mm]	[mm]	[-]	[mm]	[mm]	[mm]	
ZKLDF100	185 -0,015	160	158	136	100 -0,010	25 ±0,175	38	170	15	5,6	112	16	5,6	10	5,4	3	4
ZKLDF120	210 -0,015	184	181	159	120 -0,010	26 ±0,175	40	195	21	7	135	22	7	11	6,2	3	6
ZKLDF150	240 -0,015	214	211	188	150 -0,013	26 ±0,175	40	225	33	7	165	34	7	11	6,2	3	6
ZKLDF200	300 -0,018	274	271	243	200 -0,015	30 ±0,175	45	285	45	7	215	46	7	11	6,2	4	6
ZKLDF260	385 -0,020	345	348	313	260 -0,018	36,5 ±0,20	55	365	33	9,3	280	34	9,3	15	8,2	6	6
ZKLDF325	450 -0,023	415	413	380	325 -0,023	40 ±0,20	60	430	33	9,3	342	34	9,3	15	8,2	6	6
ZKLDF395	525 -0,028	486	488	450	395 -0,023	42,5 ±0,20	65	505	45	9,3	415	46	9,3	15	8,2	6	6
ZKLDF460	600 -0,028	560	563	520	460 -0,023	46 ±0,225	70	580	45	9,3	482	46	9,3	15	8,2	6	6

Código Code	Velocidad límite Limiting speed [r/min]	Fuerza de fricción dinámica Dynamic friction torque [Nm]	Coeficiente de carga Basic load rating		N. torn. de ensamblado Retaining screws n. R [-]	Orificios de extracción Extraction holes		Distancia de perforación Holes pitch [nxt°]	Par apriete tornillos Screw tightening torque [Nm]	Peso Weight [kg]
			Ca	Coa		Tipo Type	Cantidad Quantity			
ZKLDF100	2800	1,6	67	251	2	M5	3	18 x 20°	8,5	4,5
ZKLDF120	2400	2	72	315	2	M8	3	24 x 15°	14	6
ZKLDF150	2000	3	76	365	2	M8	3	36 x 10°	14	7,5
ZKLDF200	1600	4,5	112	550	2	M8	3	48 x 7,5°	14	11
ZKLDF260	1200	7,5	155	920	2	M12	3	36 x 10°	34	22
ZKLDF325	1000	11	165	1110	2	M12	3	36 x 10°	34	28
ZKLDF395	800	16	214	1470	2	M12	3	48 x 7,5°	34	39
ZKLDF460	700	21	255	1860	2	M12	3	48 x 7,5°	34	50

- El par de apriete se deberá aplicar en tres pasadas, al 40-70-100% del dato presente en la tabla, siguiendo una secuencia de apriete en cruz
- El rodamiento requiere una elevada calidad de las superficies de contacto para funcionar perfectamente.

- Tightening torque must be applied on 3 stages, at 40-70-100% of listed data, according crosswise tightening sequence
- The bearing requires a high quality of companion surfaces in order to work perfectly



PARTE 4 - INSTALACIÓN Y MANTENIMIENTO

PART 4 - INSTALLATION AND MAINTENANCE

CONTROL DE LA PLANEIDAD - *FLATNESS CHECK*

La corona giratoria, si bien proyectada para resistir a los máximos esfuerzos de compresión y flexión, conserva una elasticidad estructural intrínseca debida a su geometría, es decir por su reducida sección respecto a su gran diametro. Esta elasticidad estructural, con la fijación mediante tornillería del rodamiento en la estructura de soporte, produce una "adaptación" del rodamiento giratorio mismo respecto a los errores de planaridad de la superficie, que si no permanece dentro de ciertos límites, puede provocar problemas en la rotación. A continuación se exponen las diferencias máximas respecto a la planaridad ∂_p e ∂_r en dirección circunferencial y radial, **para rodamientos con juegos estándares.**

*The slewing ring, even though designed to resist to the maximum compressive and tilting loads, shows an intrinsic structural elasticity due to its own geometry, that is a reduced section compared to a large diameter. This structural elasticity, when the bearing is fixed by bolts to the companion structure, involves an "adaptation" of the bearing itself to the flatness deviation of the mounting surface. These deviations, if not contained into the limits, may generate rotational problems. Below, the permissible flatness deviations ∂_p e ∂_r , measured along the circumferential and radial directions, **valid for standard clearance bearings.***

TIPO DE RODAMIENTO BEARING TYPE	DIAMETRO DE RODADURA / RACEWAY DIAMETER										
	<500	<750	<1000	<1250	<1500	<2000	<2500	<3000	<3500	<4000	<4500
	[mm]	[mm]	[mm]	[mm]	[mm]	[mm]	[mm]	[mm]	[mm]	[mm]	[mm]
BOLAS / BALL	0,10	0,12	0,15	0,17	0,19	0,22	0,25	0,30	0,35	0,40	0,50
RODILLOS / ROLLER	0,07	0,09	0,11	0,13	0,15	0,17	0,19	0,23	0,25	0,30	0,35

Tabla de las discrepancias circunferenciales máximas $\partial_{p\max}$ en función del diámetro de rodadura.
Para rodamientos con juego reducido y precargados contactar nuestra Oficina Técnica.

*Table of values of maximum circumferential deviations $\partial_{p\max}$ depending on raceway diameter.
For reduced clearance or preloaded bearings please contact our Technical Office.*

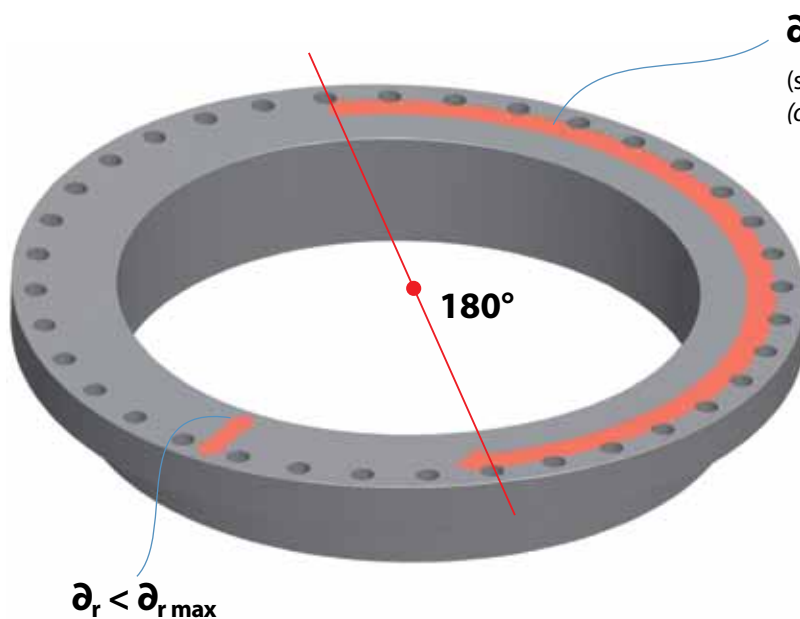

$\partial_p (0 \div 180) < \partial_{p\max}$

(sólo un pico permitido en un arco de 0 ÷ 180°)
(only one permissible peak in a arc of 0 ÷ 180°)

Para el valor máximo de discrepancia ∂_r radial asumir el siguiente valor:

About the maximum radial deviation ∂_r please refer to the following value:

$\partial_{r\max} = 0,25 \times \partial_{p\max}$

APRIETE DE LA TORNILLERÍA - BOLTS TIGHTENING

Respetar las siguientes reglas:

1. utilizar llaves dinamométricas o un tensionador hidráulico
2. utilizar siempre tornillos con vástago parcialmente roscado
3. utilizar tornillos, tuercas y arandelas planas clase 10.9, con las que se han calculado los gráficos de resistencia
4. no reutilizar la tornillería
5. controlar el apriete cada 600 horas de trabajo

Strictly follow these rules:

1. use dynamometric wrench or a hydraulic preloading tool
2. use only bolts partial threaded bolts
3. use bolts, nuts and plane washers class 10.9, the same of resistance catalogue graph
4. do not reuse bolts, nuts and washers
5. check tightening every 600 working hours

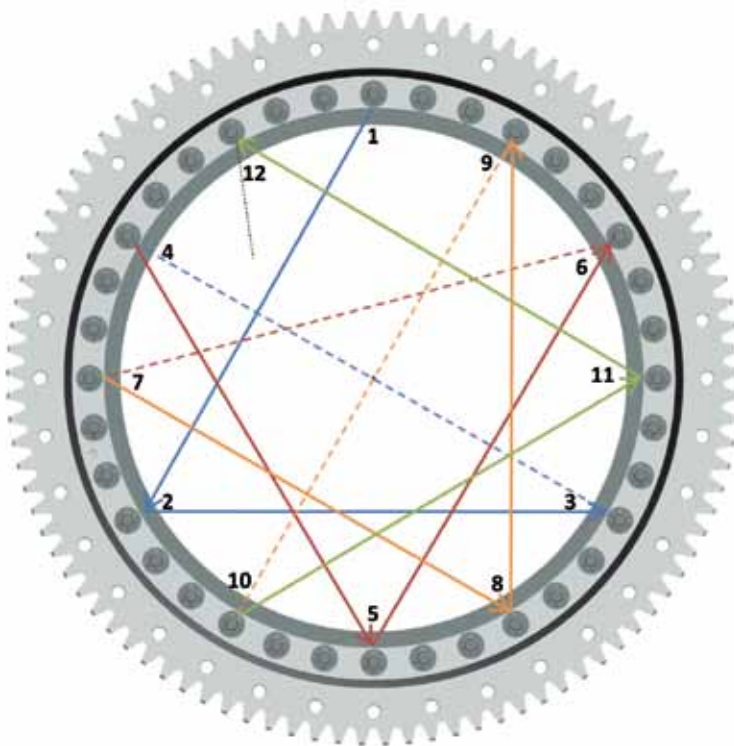

Secuencia de apriete:

se aconseja realizar el apriete en tres pasadas al 30-70-100% del valor de par de la tabla. Controlar la rotación durante el apriete.

Tightening sequence:

we recommend to tight on three steps at 30-70-100% of below torque values. Check rotation during tightening.

ROSCADO THREAD	A_s [mm ²]	F_m (Q10.9) $v = 90\%$ $\mu_G = 0.14$ [N]	TENSIONADOR HIDRÁULICO HYDRAULIC W.	LLAVE DINAMOMÉTRICA MECHANICAL W.
			M_A (Q10.9) $\mu_k = 0.14$ [Nm]	M_A (Q10.9) $\mu_k = 0.14$ [Nm]
M 10	58	38500	75	68
M 12	84,3	56000	130	117
M 14	115	77000	205	184
M 16	157	106000	310	279
M 18	192	129000	430	387
M 20	245	166000	620	558
M 22	303	208000	830	747

ROSCADO THREAD	A_s [mm ²]	F_m (Q10.9) $v = 90\%$ $\mu_G = 0.14$ [N]	TENSIONADOR HIDRÁULICO HYDRAULIC W.	LLAVE DINAMOMÉTRICA MECHANICAL W.
			M_A (Q10.9) $\mu_k = 0.14$ [Nm]	M_A (Q10.9) $\mu_k = 0.14$ [Nm]
M 24	353	239000	1060	954
M 27	459	315000	1550	1395
M 30	561	385000	2100	1890
M 33	694	480000	2800	2520
M 36	817	560000	3700	3330
M 39	976	670000	4800	4320

Valores de pre-carga (F_m) y par de apriete (M_a) para tornillería clase 10.9 (al 90% de la carga de deformación) con rosca levemente lubricada.

Pre-tensioning (F_m) and fastening torque (M_a) values for bolts class 10.9 (at 90% of yield stress) with lightly lubricated thread.

OPERACIONES PRELIMINARES - *PRELIMINARY OPERATIONS*

Las operaciones que preceden el posicionamiento del rodamiento en la respectiva estructura son las siguientes (respetar la secuencia):

1. limpieza con solventes químicos y control visual de las superficies de acople de las estructuras. Las superficies no deberán presentar rebabas ni defectos de mecanizado, por ejemplo cerca de los orificios, ni residuos de soldadura o pintura.
2. control con comparador o con la utilización de medidores láser del máximo error de planaridad de las superficies de acople según los valores límites indicados en la página 140.
3. eliminación de la capa de aceite de protección de las superficies de la corona giratoria y del dentado utilizando solventes. Se aconseja evitar todo contacto del solvente con las obturaciones de labio del rodamiento en modo tal de impedir posibles alteraciones o infiltraciones.

The preliminary operations to be performed before positioning the slew bearing on companion structures are (please follow the succession):

1. clean with chemical solvents and perform a visual check of the mounting surfaces of companion structures. Surfaces must be free from burrs or machining defects, for example in proximity of holes, or else welding or painting residues.
2. check, with a gauge device or a laser measuring device, the flatness values of companion structures observing limit values listed on page 140.
3. remove the protective oil from the bearing surfaces and gear surfaces, using a chemical solvent. In order to avoid any sealing damages, do not put in contact the solvent with the sealing.

Antes de la operación de montaje **efectuar** el control y la preparación de las superficies.

*The checking and preparation of the mounting surfaces **must** come before the mounting operation.*



MONTAJE - INSTALLATION

Las operaciones que siguen se refieren a la fijación del rodamiento en la estructura de acople. Tener en cuenta el ejemplo aplicativo expuesto a continuación.

- Para fijar el rodamiento en la estructura de acople es necesario en primis **colocar el respectivo soft spot** en la posición correcta: en el aro interior el mismo coincide con el tapón y por lo tanto se deberá orientar el aro con el tapón para formar un ángulo de aproximadamente 90° con la dirección de máximo esfuerzo operativo (flexión y compresión) en modo tal de forzar lo mínimo posible el camino de rodadura en este punto (gap de dureza).
- Antes de **apretar la tornillería** del aro interior controlar mediante rotaciones completas que el rodamiento no presentes puntos duros: luego fijar la tornillería del aro. Controlar nuevamente que el rodamiento gire uniformemente.

Following operations concern the fastening of the bearing to the companion structure. Please refer to the image below.

- In order to fasten the bearing to the companion structure it is firstly necessary to set the soft spot in the right position. On the inner ring the soft spot coincides with the filling plug, so the ring must be oriented with the filling plug at about 90° from the maximum operative load direction in order to minimize the stress in that raceway point (hardness gap).*
- Before fastening the bearing with bolts check the free rotation of the bearing: it must be without any tight spot. Then tight the bolts and finally check rotation again .*

Aro exterior / Outer ring



Marcado "S" / Stamped "S"

Aro interior / Inner ring



Soft spot del tapón / Filling plug's soft spot

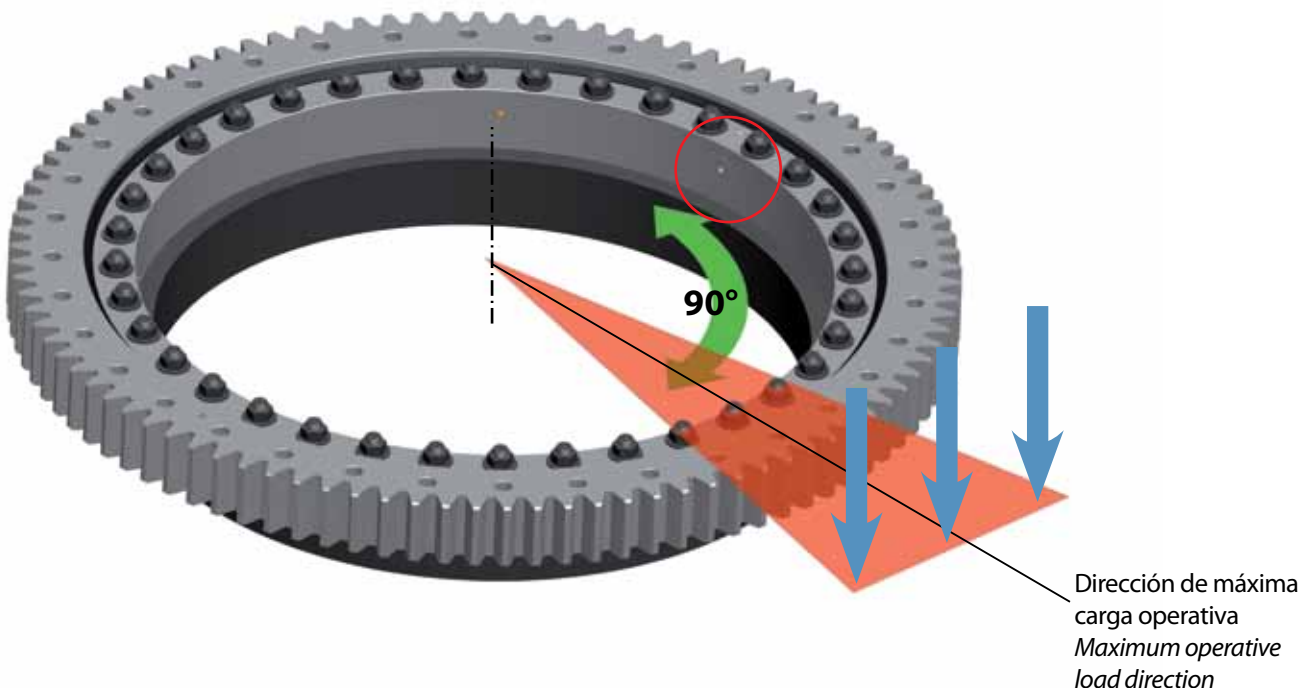

MONTAJE - INSTALLATION

6. Fijar el aro dentado en la segunda estructura y si resulta oportuno poner el soft spot, definido por la letra "S" grabada, a 90° aproximadamente de la posición de máximo carga. Efectuar luego el apriete de la tornillería.
 7. Será necesario luego **posicionar** el motorreductor que determina la rotación de la estructura. Su reglaje se logra regulando el juego δ_f del piñón en el punto de máxima excentricidad del dentado (o mínima, para las coronas giratorias dentadas interiores) definido por **tres dientes pintados de verde** (véase imagen inferior). En este punto se evidencia el máximo valor de run out del dentado por afuera de la circunferencia original, por lo tanto regulando el juego rodamiento giratorio-piñón al valor de $0,03 \div 0,04$ veces el valor del módulo en todos los restantes puntos, la rotación se verificará sin interferencias.
6. Fasten the geared ring to the second companion structure and, if suitable, set the soft spot defined by the stamped letter "S" at 90° from the maximum load direction. Then fasten the bolts.
7. Now it is necessary to assemble the gearbox to the structure. The fine position is determined by checking the backlash δ_f of the pinion teeth in the point of maximum eccentricity of the bearing gear, defined by three green painted teeth (see image below). This point represents the maximum run-out value of the gear outside the pitch diameter so, adjusting in this point the clearance pinion-bearing between 0,03 and 0,04 the module value, the rotation in all the other points will be ensured.

MÓDULO MODULE	MIN δ_f	MAX δ_f
	[mm]	[mm]
4	0,12	0,16
4,5	0,13	0,18
5	0,15	0,2
6	0,18	0,24
8	0,24	0,32
10	0,3	0,4
12	0,36	0,48
14	0,42	0,56
16	0,48	0,64
18	0,54	0,72
20	0,6	0,8
22	0,66	0,88
24	0,72	0,96
25	0,75	1
28	0,84	1,12
30	0,9	1,2

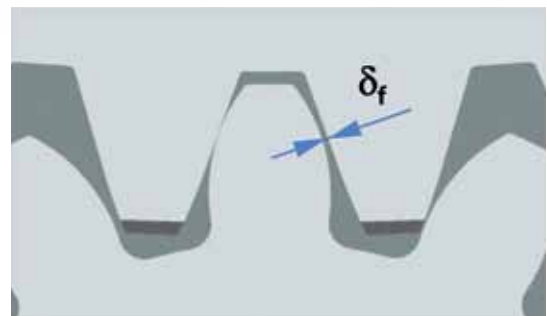
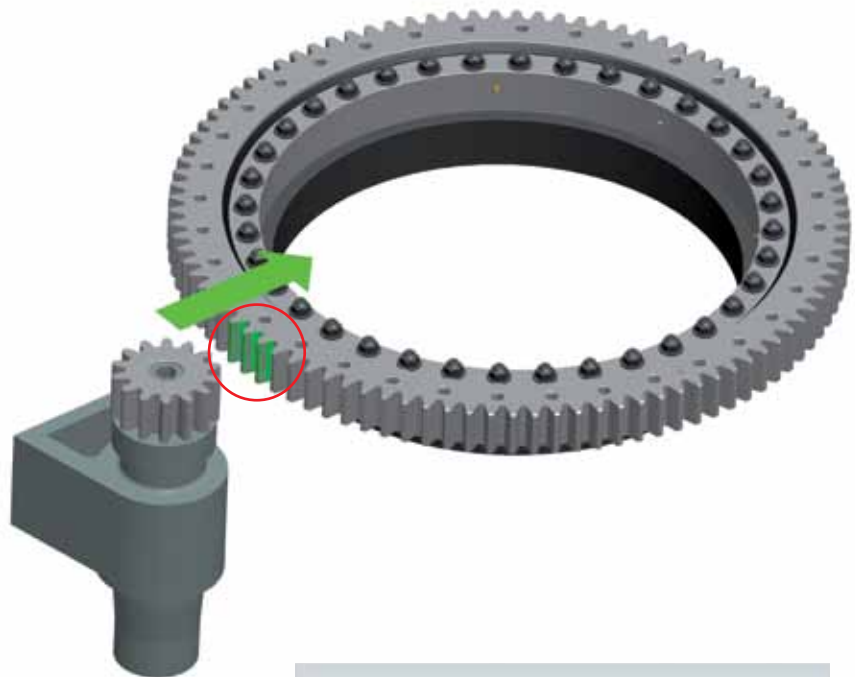

Para controlar el juego de engrane utilizar un calibre de espesor
 To check the setting of the pinion backlash use a thickness gauge.

LUBRICACIÓN DE LOS CAMINOS DE RODADURA - *RACEWAY LUBRICATION*

La lubricación de los caminos de rodadura se efectúa inmediatamente después del montaje o en fases intermedias, cuando la operación resulte más cómoda. Se deberá de todos modos efectuar siempre una re-lubricación del rodamiento antes de poner en función la máquina o después de un prolongado período de parada. Es conveniente que durante el funcionamiento exista siempre una película de grasa fresca en el borde de la obturación, que impida la contaminación con agentes externos.

La operación de reengrase se deberá efectuar:

- ✓ cada 100 horas de actividad de la máquina en la cual está montado (no sólo de rotación)
- ✓ con la corona giratoria en rotación
- ✓ utilizando todos los engrasadores

La condición ideal es cuando aparece una película de grasa fresca en todo el borde de las obturaciones.

El reengrase sirve también para evacuar los caminos de rodadura de eventual suciedad interna acumulada. Si no resulta posible girar la corona giratoria durante el reengrase es necesario prever un mayor número de engrasadores.

Véase la lista de grasas detallada a continuación, las cuales podrán también mezclarse siempre que resulten compatibles (atención al ΔT).

The raceway lubrication may be conducted just after the installation of the bearing or in a intermediate phase. In any case an accurate re-greasing of the bearing must be performed before the machine start-up or before a long standstill time. It is an optimum condition that, during machine activity, the sealing shall be always protected by a layer of fresh grease coming out from the raceway, in order to avoid external contamination.

The re-greasing operation must be performed:

- ✓ every 100 hours of machine activity (not only rotation time)
- ✓ with the bearing in continuous rotation
- ✓ using whole greases

The operation is completed when a collar of fresh grease appears along the sealing of the bearing.

The re-greasing is also useful to evacuate the raceway from eventual internal moisture. If the bearing cannot rotate during this operation, the bearing design must include a major number of greasers. If necessary, lubricants can be mixed (check ΔT).

FABRICANTE PRODUCER	NOMBRE DE LA GRASA (ΔT) GREASE NAME (ΔT)
	GR MU EP 2 -20° to +110
	ARALUB HLP 2 -20° to +130 °C
	ENERGREASE LS-EP 2 -20° to +130 °C
	SPHEEROL EPL 2 -20°C to +120°C
	LAGERMEISTER EP 2 -20°C to +130°C











FABRICANTE PRODUCER	NOMBRE DE LA GRASA (ΔT) GREASE NAME (ΔT)
	BEACON EP 2 -20°C to +120°C
	MOBILUX EP 2 -20°C to +120°C
	ALVANIA EP 2 -20° to +130 °C
	MULTIS EP 2 -25° to +120 °C
	CENTOPLEX EP 2 -25° to +130 °C

Lubricantes para los caminos de rodadura / *Lubricant for raceways*

LUBRICACIÓN DEL DENTADO - GEAR LUBRICATION

La lubricación del dentado se deberá planificar en función de la utilización y del ambiente en el cual se instalará el rodamiento. Se aconseja instalar un sistema de lubricación automática del dentado, por ejemplo cerca del piñón, en modo tal de redistribuir la grasa en las zonas más necesarias. Es necesario de todos modos efectuar siempre manualmente una lubricación completa en todo el dentado antes de la puesta en función de la máquina, con un pincel limpio o un sistema spray, quitando la grasa en exceso.

The gear lubrication may be planned in function of the working characteristics and the environment conditions in which the bearing has been installed. We suggest to design an automatic lubrication gear system, for example in proximity of the pinion, in order to redistribute the grease on the most used part of the bearing gear. In any case, a complete gear lubrication must be manually performed just before the machine start-up, using a clean brush or a spray system, and then removing exceeded grease.

FABRICANTE PRODUCER	NOMBRE DE LA GRASA (ΔT) GREASE NAME (ΔT)	FABRICANTE PRODUCER	NOMBRE DE LA GRASA (ΔT) GREASE NAME (ΔT)
	GR MU EP 2 -20° to +110		Multi purpose grease (Molly) -20°C to +130°C
	ARALUB MKA-Z-1 -25° to +180 °C		MOBILGEAR OGL 461 -20°C to +120°C
	ENERGREASE LC2 -30° to +140 °C		MALLEUS OGH -10° to +200 °C
	LMX -20°C to +120°C		GARDREXA GR-1 AL -20° to + 200 °C
	CEPLATTYN KG 10 HMF -10°C to +140°C		GRAFLOSCON C-SG 0 ultra -30° to +200 °C

Lubricantes para el dentado de corona giratoria y piñón / Lubricant for pinion and bearing gear

MANIPULACIÓN Y ALMACENAJE - *HANDLING & STORAGE*

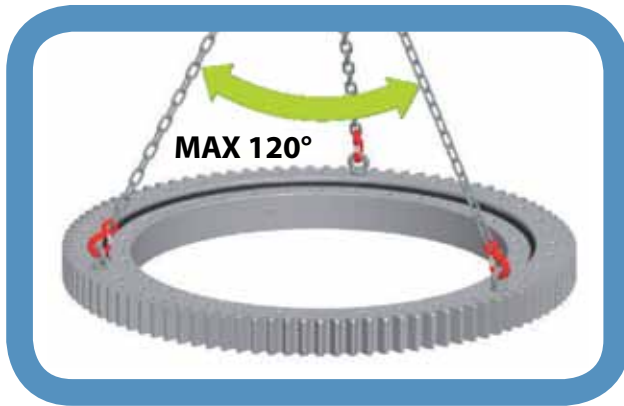

MANIPULACIÓN / *HANDLING*

Para una manipulación óptima del rodamiento utilizar como mínimo 3 anillos embulonados en los orificios de la corona giratoria y distribuidos en modo uniforme a lo largo de la circunferencia. No abrir el ángulo de las cadenas a más de 120°.

For an optimal handling of the bearing, use at least 3 eyebolts fixed to the bearings holes, equally spaced along the circumference. Do not exceed the chain angle over 120°.

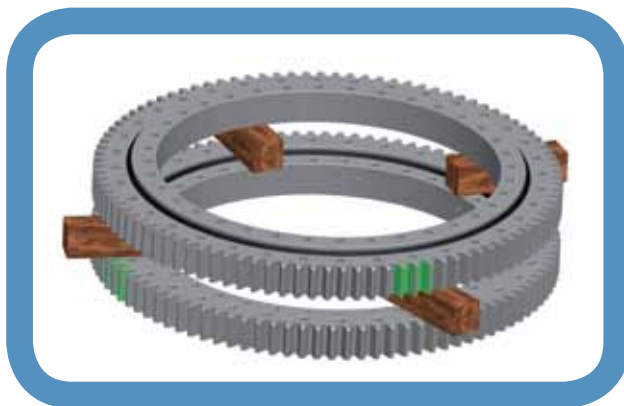

Si resulta necesario apilar rodamientos, para evitar daños a las superficies de contacto, intercalar entre los rodamientos apilados espaciadores de madera entre los aros.

If the bearings must be piled, interpose wooden spacers between matching rings, in order to avoid damages on bearing surfaces.



ALMACENAJE / *STORAGE*

Almacenar los rodamientos horizontalmente en sus cajones de madera o bien en los respectivos pallets, protegidos con celofán, evitando el contacto directo con el suelo.

Storage the bearings horizontally in their own wooden crate or else on their pallet protected with cellophane, avoiding direct contact with the ground.



Almacenarlos en lo posible en ambiente cerrado y siempre protegidos de los agentes atmosféricos, en zonas con temperaturas constantes y lejos de zonas húmedas. Controlar el estado del aceite protector cada 6-12 meses en función del tipo de ambiente de almacenaje.

Stock the bearings preferably in indoor dry areas at constant temperature, in any case repaired from weather agents and humidity. Check the protective oil coating every 6-12 months basing on stock conditions.





PARTE 5 - TABLAS DE EQUIVALENCIAS DE LAS CORONAS GIRATORIAS

PART 5 - CROSSED REFERENCE TABLES FOR SLEWING BEARINGS

LISTADO DE LAS CORONAS GIRATORIAS PARA EXCAVADORAS - LIST OF SLEWING RING FOR EXCAVATORS



- 1 - Komatsu PC40-10
- 2 - Komatsu PW60-5
- 3 - Komatsu PC60-5(1)
- 4 - Komatsu PC60-5(2)
- 5 - Komatsu PC60-6(Z=76)
- 6 - Komatsu PC60-6(Z=80)
- 7 - Komatsu PC60-7(Z=76)
- 8 - Komatsu PC60-7(Z=80)
- 9 - Komatsu PC90-6
- 10 - Komatsu PC100-5
- 11 - Komatsu PC120-5
- 12 - Komatsu PC120-6(4D95)
- 13 - Komatsu PC120-6(4D102)
- 14 - Komatsu PC130-7
- 15 - Komatsu PC150-7
- 16 - Komatsu PC20HT
- 17 - Komatsu PC200-1
- 18 - Komatsu PC200-2
- 19 - Komatsu PC200-3
- 20 - Komatsu PC200-5
- 21 - Komatsu PC200-6 (1)
- 22 - Komatsu PC200-6 (2)
- 23 - Komatsu PC200-6(New)
- 24 - Komatsu PC200-6(6D95)
- 25 - Komatsu PC200-7
- 26 - Komatsu PC200-8
- 27 - Komatsu PC220-3
- 28 - Komatsu PC220-5
- 29 - Komatsu PC220-7
- 30 - Komatsu PC220-8
- 31 - Komatsu PC228
- 32 - Komatsu PC240-8
- 33 - Komatsu PC300-2
- 34 - Komatsu PC300-3
- 35 - Komatsu PC300-5
- 36 - Komatsu PC300-6
- 37 - Komatsu PC350-6
- 38 - Komatsu PC360-7
- 39 - Komatsu PC400-1
- 40 - Komatsu PC400-3
- 41 - Komatsu PC400-5
- 42 - Komatsu PC400-6
- 43 - Komatsu PC450-5
- 44 - Komatsu PC450-6
- 45 - Komatsu PC450-7
- 46 - Komatsu PC650
- 47 - Hitachi EX60-1
- 48 - Hitachi EX60-2,3
- 49 - Hitachi EX60-5
- 50 - Hitachi EX90
- 51 - Hitachi EX100-5
- 52 - Hitachi EX120-2
- 53 - Hitachi EX120-3
- 54 - Hitachi ZX120
- 55 - Hitachi EX120-1
- 56 - Hitachi EX120-5
- 57 - Hitachi EX150
- 58 - Hitachi EX160WD-1
- 59 - Hitachi EX200-1
- 60 - Hitachi EX200-2,3,5
- 61 - Hitachi ZX200
- 62 - Hitachi EX210-5
- 63 - Hitachi ZX210
- 64 - Hitachi EX220-5
- 65 - Hitachi ZX225U (1)
- 66 - Hitachi ZX225U (2)
- 67 - Hitachi ZX230
- 68 - Hitachi ZX240
- 69 - Hitachi ZX270
- 70 - Hitachi EX300-1
- 71 - Hitachi EX300-2
- 72 - Hitachi EX300-3
- 73 - Hitachi EX300-5
- 74 - Hitachi ZX330
- 75 - Hitachi ZX350-5
- 76 - Hitachi ZX450H
- 77 - Kato HD250-7
- 78 - Kato HD450-5
- 79 - Kato HD450-7
- 80 - Kato HD450
- 81 - Kato HD512
- 82 - Kato HD516
- 83 - Kato HD770SE
- 84 - Kato HD770-1
- 85 - Kato HD770-2
- 86 - Kato HD700-2
- 87 - Kato HD700-5
- 88 - Kato HD700-7
- 89 - Kato HD800-5
- 90 - Kato HD800-7
- 91 - Kato HD820-1
- 92 - Kato HD820-3
- 93 - Kato HD1250/1430
- 94 - Kobelco SK120-5
- 95 - Kobelco SK130-7
- 96 - Kobelco SK07-1
- 97 - Kobelco SK07-1-N2
- 98 - Kobelco SK07-N2 (1)
- 99 - Kobelco SK07-N2 (2)
- 100 - Kobelco SK07-2
- 101 - Kobelco SK907B
- 102 - Kobelco SK09
- 103 - Kobelco SK03
- 104 - Kobelco SK04
- 105 - Kobelco SK60-5
- 106 - Kobelco SK60-6
- 107 - Kobelco SK200-3/5
- 108 - Kobelco SK200-6
- 109 - Kobelco SK210-6E
- 110 - Kobelco SK200-8
- 111 - Kobelco SK235
- 112 - Kobelco SK330-3
- 113 - Kobelco SK350
- 114 - Kobelco SK450-6E
- 115 - Sumitomo SH60-1
- 116 - Sumitomo SH120-1
- 117 - Sumitomo SH120-2
- 118 - Sumitomo SH120-3
- 119 - Sumitomo SH120
- 120 - Sumitomo SH140
- 121 - Sumitomo SH145
- 122 - Sumitomo SH200A1
- 123 - Sumitomo SH200A2
- 124 - Sumitomo SH200A3
- 125 - Sumitomo SH20002
- 126 - Sumitomo SH20003
- 127 - Sumitomo SH220-2
- 128 - Sumitomo SH220-3
- 129 - Sumitomo SH225
- 130 - Sumitomo SH260
- 131 - Sumitomo SH265
- 132 - Sumitomo SH280
- 133 - Sumitomo SH300-2
- 134 - Sumitomo SH300-3
- 135 - Sumitomo SH330
- 136 - Sumitomo SH340
- 137 - Sumitomo SH350
- 138 - Sumitomo SH40T
- 139 - Sumitomo SH430
- 140 - Sumitomo DH55-3
- 141 - Daewoo DH55-5
- 142 - Daewoo DH200-3
- 143 - Daewoo DH220-2
- 144 - Daewoo DH220-3
- 145 - Daewoo DH220-5
- 146 - Daewoo DH220-7LC
- 147 - Daewoo DH225-7
- 148 - Daewoo DH280
- 149 - Daewoo DH290-5
- 150 - Daewoo DH300-5
- 151 - Daewoo DH300-7
- 152 - Daewoo DH10L
- 153 - Daewoo DH320
- 154 - Daewoo DH330-3
- 155 - Caterpillar CAT110
- 156 - Caterpillar CAT215
- 157 - Caterpillar CAT215B
- 158 - Caterpillar CAT225
- 159 - Caterpillar CAT280
- 160 - Caterpillar CAT200B
- 161 - Caterpillar CAT305.5
- 162 - Caterpillar CAT320B
- 163 - Caterpillar CAT320C
- 164 - Caterpillar CAT320D
- 165 - Caterpillar CAT320L
- 166 - Caterpillar CAT325
- 167 - Caterpillar CAT325B
- 168 - Caterpillar CAT325C
- 169 - Caterpillar CAT330C
- 170 - Hyundai R55-7
- 171 - Hyundai R60-5
- 172 - Hyundai R60-7(1)
- 173 - Hyundai R60-7(2)
- 174 - Hyundai R110-7
- 175 - Hyundai R130-5
- 176 - Hyundai R130-7
- 177 - Hyundai R170-5
- 178 - Hyundai R200-5
- 179 - Hyundai R200-7
- 180 - Hyundai R210-3
- 181 - Hyundai R215-7
- 182 - Hyundai R220-5
- 183 - Hyundai R225-7
- 184 - Hyundai R260LC-7
- 185 - Hyundai R290
- 186 - Hyundai R305LC-7
- 187 - Hyundai R300
- 188 - Volvo EC210B
- 189 - Volvo EC210
- 190 - Volvo EC290
- 191 - Volvo EC360
- 192 - Samsung PS132
- 193 - Samsung PS210
- 194 - Samsung PS292
- 195 - Samsung MX08-2
- 196 - Liebherr 914
- 197 - Liebherr 924
- 198 - Liebherr 934
- 199 - Case CX240
- 200 - Mitsubishi 230
- 201 - Atlas 3306



LISTADO DE EQUIVALENCIA DE LAS CORONAS GIRATORIAS - SLEWING BEARING CROSS REFERENCE LIST

CÓDIGO ISB ISB CODE	ROTHERDE	IMO	SKF	MRI	TORRIANI	RIMA	INA
ZK con perforación / with holes							
ZK.22.0500.100-1SPPN				I.1.050-159/259			
ZK.22.0700.100-1SPPN				I.1.070-159/259			
ZK.22.0800.100-1SPPN				I.1.080-159/259			
ZK.22.0880.100-1SPPN				I.1.088-159/259			
ZK.22.1000.100-1SPPN				I.1.100-159/259			
ZK.22.1100.100-1SPPN							
ZK sin perforación / no holes							
ZK.22.0500.100-1SN				I.1.050-150/250	I.500.22.00.A-T	2UI.050.00	
ZK.22.0700.100-1SN				I.1.070-150/250	I.700.22.00.A-T	2UI.070.00	
ZK.22.0800.100-1SN				I.1.080-150/250	I.800.22.00.A-T	2UI.080.00	
ZK.22.0880.100-1SN				I.1.088-150/250	I.880.22.00.A-T	2UI.088.00	
ZK.22.1000.100-1SN				I.1.100-150/250	I.1000.22.00.A-T	2UI.100.00	
ZK.22.1100.100-1SN					I.1100.22.00.A-T	2UI.110.00	
NK con perforación / with holes							
NK.22.0400.100-1PPN				I.1.040-179/279			
NK.22.0500.100-1PPN				I.1.050-179/279			
NK.22.0700.100-1PPN				I.1.070-179/279			
NK.22.0800.100-1PPN				I.1.080-179/279			
NK.22.0880.100-1PPN				I.1.088-179/279			
NK.22.1000.100-1PPN				I.1.100-179/279			
NK.22.1100.100-1PPN							
NK sin perforación / no holes							
NK.22.0400.100-1N				I.1.040-170/270	I.400.22.00.A/SD-T	2UN.040.00	
NK.22.0500.100-1N				I.1.050-170/270	I.500.22.00.A/SD-T	2UN.050.00	
NK.22.0700.100-1N				I.1.070-170/270	I.700.22.00.A/SD-T	2UN.070.00	
NK.22.0800.100-1N				I.1.080-170/270	I.800.22.00.A/SD-T	2UN.080.00	
NK.22.0880.100-1N				I.1.088-170/270	I.880.22.00.A/SD-T	2UN.088.00	
NK.22.1000.100-1N				I.1.100-170/270	I.1000.22.00.A/SD-T	2UN.100.00	
NK.22.1100.100-1N					I.1100.22.00.A/SD-T	2UN.110.00	
EBL.20 S							
EBL.20.0314.200-1STPN		91-20 0311/1-07102					
EBL.20.0414.200-1STPN	231.20.0400.013	91-20 0411/1-07112	RKS.21 0411		E.505.20.00.C	2CE.050.00	VLA 20 0414 N
EBL.20.0544.200-1STPN	231.20.0500.013	91-20 0541/1-07122	RKS.21 0541		E.650.20.00.C	2CE.064.00	VLA 20 0544 N
EBL.20.0644.200-1STPN	231.20.0600.013	91-20 0641/1-07132	RKS.21 0641		E.750.20.00.C	2CE.074.00	VLA 20 0644 N
EBL.20.0744.200-1STPN	231.20.0700.013	91-20 0741/1-07142	RKS.21 0741		E.850.20.00.C	2CE.083.00	VLA 20 0744 N
EBL.20.0844.200-1STPN	231.20.0800.013	91-20 0841/1-07152	RKS.21 0841		E.950.20.00.C	2CE.095.00	VLA 20 0844 N
EBL.20.0944.200-1STPN	231.20.0900.013	91-20 0941/1-07162	RKS.21 0941		E.1050.20.00.C	2CE.104.00	VLA 20 0944 N
EBL.20.1094.200-1STPN	231.20.1000.013	91-20 1091/1-07172	RKS.21 1091		E.1200.20.00.C	2CE.119.00	VLA 20 1094 N
EBL.20 P							
EBL.20.0314.201-2STPN		91-20 0311/1-07103					
EBL.20.0414.201-2STPN	231.21.0475.013	91-20 0411/1-07113					
EBL.20.0544.201-2STPN	231.21.0575.013	91-20 0541/1-07123					
EBL.20.0644.201-2STPN	231.21.0675.013	91-20 0641/1-07133					
EBL.20.0744.201-2STPN	231.21.0775.013	91-20 0741/1-07143					
EBL.20.0844.201-2STPN	231.21.0875.013	91-20 0841/1-07153					
EBL.20.0944.201-2STPN	231.21.0975.013	91-20 0941/1-07163					
EBL.20.1094.201-2STPN	231.21.1075.013	91-20 1091/1-07173					

Nota: esta es una tabla de referencia. Se aconseja siempre de controlar la correspondencia con los dibujos o tablas
 Note: this table is for reference use only. Please always check adaptability with drawings or tables comparison

Código ISB ISB Code	ROTHERDE	IMO	SKF	MRI	TORRIANI	RIMA	INA
EBL.30 S							
EBL.30.0955.200-1STPN	281.30.0900.013	91-32 0955/1-06115			E.1100.32.00.C	2PE.100.00	
EBL.30.1055.200-1STPN	281.30.1000.013	91-32 1055/1-06125			E.1200.32.00.C	2PE.120.00	
EBL.30.1155.200-1STPN	281.30.1100.013	91-32 1155/1-06135			E.1300.32.00.C	2PE.130.00	
EBL.30.1255.200-1STPN	281.30.1200.013	91-32 1255/1-06145			E.1400.32.00.C	2PE.140.00	
EBL.30.1355.200-1STPN	281.30.1300.013	91-32 1355/1-06155			E.1500.32.00.C	2PE.150.00	
EBL.30.1455.200-1STPN	281.30.1400.013	91-32 1455/1-06165			E.1600.32.00.C	2PE.160.00	
EBL.30 P							
EBL.30.0955.201-2STPN	281.30.0975.013						
EBL.30.1055.201-2STPN	281.30.1075.013						
EBL.30.1155.201-2STPN	281.30.1175.013						
EBL.30.1255.201-2STPN	281.30.1275.013						
EBL.30.1355.201-2STPN	281.30.1375.013						
EBL.30.1455.201-2STPN	281.30.1475.013						
ZBL.20 S							
ZBL.20.0314.200-1SPTN		92-20 0311/1-07202					
ZBL.20.0414.200-1SPTN	232.20.0400.013	92-20 0411/1-07212	RKS.22 0411		I.505.20.00.C	2CI.051.00	VLI 20 0414 N
ZBL.20.0544.200-1SPTN	232.20.0500.013	92-20 0541/1-07222	RKS.22 0541		I.650.20.00.C	2CI.064.00	VLI 20 0544 N
ZBL.20.0644.200-1SPTN	232.20.0600.013	92-20 0641/1-07232	RKS.22 0641		I.750.20.00.C	2CI.074.00	VLI 20 0644 N
ZBL.20.0744.200-1SPTN	232.20.0700.013	92-20 0741/1-07242	RKS.22 0741		I.850.20.00.C	2CI.084.00	VLI 20 0744 N
ZBL.20.0844.200-1SPTN	232.20.0800.013	92-20 0841/1-07252	RKS.22 0841		I.950.20.00.C	2CI.094.00	VLI 20 0844 N
ZBL.20.0944.200-1SPTN	232.20.0900.013	92-20 0941/1-07262	RKS.22 0941		I.1050.20.00.C	2CI.104.00	VLI 20 0944 N
ZBL.20.1094.200-1SPTN	232.20.1000.013	92-20 1091/1-07272	RKS.22 1091		I.1200.20.00.C	2CI.119.00	VLI 20 1094 N
ZBL.20 P							
ZBL.20.0314.201-2SPTN		92-20 0311/1-07203					
ZBL.20.0414.201-2SPTN	232.21.0475.013	92-20 0411/1-07213					
ZBL.20.0544.201-2SPTN	232.21.0575.013	92-20 0541/1-07223					
ZBL.20.0644.201-2SPTN	232.21.0675.013	92-20 0641/1-07233					
ZBL.20.0744.201-2SPTN	232.21.0775.013	92-20 0741/1-07243					
ZBL.20.0844.201-2SPTN	232.21.0875.013	92-20 0841/1-07253					
ZBL.20.0944.201-2SPTN	232.21.0975.013	92-20 0941/1-07263					
ZBL.20.1094.201-2SPTN	232.21.1075.013	92-20 1091/1-07273					
ZBL.30 S							
ZBL.30.0955.200-1SPTN	282.30.0900.013	92-32 0955/1-06215			I.1100.32.00.C	2PI.110.00	
ZBL.30.1055.200-1SPTN	282.30.1000.013	92-32 1055/1-06225			I.1200.32.00.C	2PI.120.01	
ZBL.30.1155.200-1SPTN	282.30.1100.013	92-32 1155/1-06235			I.1300.32.00.C	2PI.130.00	
ZBL.30.1255.200-1SPTN	282.30.1200.013	92-32 1255/1-06245			I.1400.32.00.C	2PI.140.00	
ZBL.30.1355.200-1SPTN	282.30.1300.013	92-32 1355/1-06255			I.1500.32.00.C	2PI.150.00	
ZBL.30.1455.200-1SPTN	282.30.1400.013	92-32 1455/1-06265			I.1600.32.00.C	2PI.160.00	
ZBL.30 P							
ZBL.30.0955.201-2SPTN	281.30.0975.013						
ZBL.30.1055.201-2SPTN	281.30.1075.013						
ZBL.30.1155.201-2SPTN	281.30.1175.013						
ZBL.30.1255.201-2SPTN	281.30.1275.013						
ZBL.30.1355.201-2SPTN	281.30.1375.013						
ZBL.30.1455.201-2SPTN	281.30.1475.013						
NBL.20 S							
NBL.20.0314.200-1PPN		90-20 0311/0-07002				2C.0418.00	
NBL.20.0414.200-1PPN	230.20.0400.013	90-20 0411/0-07012	RKS.23 0411		SD.505.20.00.C	2C.0518.00	VLU 20 0414 N
NBL.20.0544.200-1PPN	230.20.0500.013	90-20 0541/0-07022	RKS.23 0541		SD.650.20.00.C	2C.0648.00	VLU 20 0544 N
NBL.20.0644.200-1PPN	230.20.0600.013	90-20 0641/0-07032	RKS.23 0641		SD.750.20.00.C	2C.0748.00	VLU 20 0644 N
NBL.20.0744.200-1PPN	230.20.0700.013	90-20 0741/0-07042	RKS.23 0741		SD.850.20.00.C	2C.0848.00	VLU 20 0744 N
NBL.20.0844.200-1PPN	230.20.0800.013	90-20 0841/0-07052	RKS.23 0841		SD.950.20.00.C	2C.0948.00	VLU 20 0844 N

Código ISB ISB Code	ROTHE ERDE	IMO	SKF	MRI	TORRIANI	RIMA	INA
NBL.20.0944.200-1PPN	230.20.0900.013	90-20 0941/0-07062	RKS.23 0941		SD.1050.20.00.C	2C.1048.00	VLU 20 0944 N
NBL.20.1094.200-1PPN	230.20.1000.013	90-20 1091/0-07072	RKS.23 1091		SD.1200.20.00.C	2C.1198.00	VLU 20 1094 N
NBL.20 P							
NBL.20.0314.201-2PPN		90-20 0311/0-07003					
NBL.20.0414.201-2PPN	230.21.0475.013	90-20 0411/0-07013					
NBL.20.0544.201-2PPN	230.21.0575.013	90-20 0541/0-07023					
NBL.20.0644.201-2PPN	230.21.0675.013	90-20 0641/0-07033					
NBL.20.0744.201-2PPN	230.21.0775.013	90-20 0741/0-07043					
NBL.20.0844.201-2PPN	230.21.0875.013	90-20 0841/0-07053					
NBL.20.0944.201-2PPN	230.21.0975.013	90-20 0941/0-07063					
NBL.20.1094.201-2PPN	230.21.1075.013	90-20 1091/0-07073					
NBL.30 S							
NBL.30.0955.200-1PPN	280.30.0900.013	90-32 0955/0-06015			SD.1100.32.00.C	2CP.110.00	
NBL.30.1055.200-1PPN	280.30.1000.013	90-32 1055/0-06025			SD.1200.32.00.C	2CP.120.01	
NBL.30.1155.200-1PPN	280.30.1100.013	90-32 1155/0-06035			SD.1300.32.00.C	2CP.130.00	
NBL.30.1255.200-1PPN	280.30.1200.013	90-32 1255/0-06045			SD.1400.32.00.C	2CP.140.00	
NBL.30.1355.200-1PPN	280.30.1300.013	90-32 1355/0-06055			SD.1500.32.00.C	2CP.150.00	
NBL.30.1455.200-1PPN	280.30.1400.013	90-32 1455/0-06065			SD.1600.32.00.C	2CP.160.00	
NBL.30 P							
NBL.30.0955.201-2PPN	280.30.0975.013						
NBL.30.1055.201-2PPN	280.30.1075.013						
NBL.30.1155.201-2PPN	280.30.1175.013						
NBL.30.1255.201-2PPN	280.30.1275.013						
NBL.30.1355.201-2PPN	280.30.1375.013						
NBL.30.1455.201-2PPN	280.30.1475.013						
EB1.20 S							
EB1.20.0314.200-1STPN		11-20 0311/1-02102					
EB1.20.0414.200-1STPN	061.20.0414.500.01.1503	11-20 0411/1-02112	RKS.061.20.0414	E.1.051-200	E.505.20.00 B	2IE.050.00	VSA 20 0414 N
EB1.20.0544.200-1STPN	061.20.0544.500.01.1503	11-20 0541/1-02122	RKS.061.20.0544	E.1.062-200	E.650.20.00 B	2IE.064.00	VSA 20 0544 N
EB1.20.0644.200-1STPN	061.20.0644.500.01.1503	11-20 0641/1-02132	RKS.061.20.0644		E.750.20.00 B	2IE.074.00	VSA 20 0644 N
EB1.20.0744.200-1STPN	061.20.0744.500.01.1503	11-20 0741/1-02142	RKS.061.20.0744		E.850.20.00 B	2IE.083.00	VSA 20 0744 N
EB1.20.0844.200-1STPN	061.20.0844.500.01.1503	11-20 0841/1-02152	RKS.061.20.0844		E.950.20.00 B	2IE.095.00	VSA 20 0844 N
EB1.20.0944.200-1STPN	061.20.0944.500.01.1503	11-20 0941/1-02162	RKS.061.20.0944		E.1050.20.00 B	2IE.104.00	VSA 20 0944 N
EB1.20.1094.200-1STPN	061.20.1094.500.01.1503	11-20 1091/1-02172	RKS.061.20.1094		E.1200.20.00 B	2IE.119.00	VSA 20 1094 N
EB1.20 P							
EB1.20.0314.201-2STPN		11-20 0311/1-02103					
EB1.20.0414.201-2STPN	061.20.0414.575.01.1403	11-20 0411/1-02113					
EB1.20.0544.201-2STPN	061.20.0544.575.01.1403	11-20 0541/1-02123					
EB1.20.0644.201-2STPN	061.20.0644.575.01.1403	11-20 0641/1-02133					
EB1.20.0744.201-2STPN	061.20.0744.575.01.1403	11-20 0741/1-02143					
EB1.20.0844.201-2STPN	061.20.0844.575.01.1403	11-20 0841/1-02153					
EB1.20.0944.201-2STPN	061.20.0944.575.01.1403	11-20 0941/1-02163					
EB1.20.1094.201-2STPN	061.20.1094.575.01.1403	11-20 1091/1-02173					
EB1.25 S							
EB1.25.0455.200-1STPN		11-25 0455/1-04110					
EB1.25.0555.200-1STPN		11-25 0555/1-04120					
EB1.25.0655.200-1STPN		11-25 0655/1-04130					
EB1.25.0755.200-1STPN		11-25 0755/1-04140					VSA 25 0755 N
EB1.25.0855.200-1STPN	061.25.0855.500.11.1503	11-25 0855/1-03110					VSA 25 0855 N
EB1.25.0955.200-1STPN	061.25.0955.500.11.1503	11-25 0955/1-03120					VSA 25 0955 N
EB1.25.1055.200-1STPN	061.25.1055.500.11.1503	11-25 1055/1-03130					VSA 25 1055 N

Nota: esta es una tabla de referencia. Se aconseja siempre de controlar la correspondencia con los dibujos o tablas
Note: this table is for reference use only. Please always check adaptability with drawings or tables comparison

Código ISB ISB Code	ROTHERDE	IMO	SKF	MRI	TORRIANI	RIMA LEONESSA	INA
EB1.25.1155.200-1STPN	061.25.1155.500.11.1503	11-25 1155/1-03140					
EB1.25.1255.200-1STPN	061.25.1255.500.11.1503	11-25 1255/1-03150					
EB1.25.1355.200-1STPN	061.25.1355.500.11.1503	11-25 1355/1-03160					
EB1.25.1455.200-1STPN	061.25.1455.500.11.1503	11-25 1455/1-03170					
EB1.25 P							
EB1.25.0455.201-2STPN							
EB1.25.0555.201-2STPN							
EB1.25.0655.201-2STPN							
EB1.25.0755.201-2STPN					E.900.25.00.B		VSA 25 0755 N ZT
EB1.25.0855.201-2STPN	061.25.0855.575.11.1403				E.1000.25.00.B		VSA 25 0855 N ZT
EB1.25.0955.201-2STPN	061.25.0955.575.11.1403				E.1100.25.00.B		VSA 25 0955 N ZT
EB1.25.1055.201-2STPN	061.25.1055.575.11.1403				E.1200.25.00.B		VSA 25 1055 N ZT
EB1.25.1155.201-2STPN	061.25.1155.575.11.1403						
EB1.25.1255.201-2STPN	061.25.1255.575.11.1403						
EB1.25.1355.201-2STPN	061.25.1355.575.11.1403						
EB1.25.1455.201-2STPN	061.25.1455.575.11.1403						
EB1.25 R							
EB1.25.1204.400 -1SPPN			RKS.061.25.1204				
EB1.25.1314.400-1SPPN			RKS.061.25.1314				
EB1.25.1424.400 -1SPPN			RKS.061.25.1424				
EB1.25.1534.400 -1SPPN			RKS.061.25.1534				
EB1.25.1644.400 -1SPPN			RKS.061.25.1644				
EB1.25.1754.400 -1SPPN			RKS.061.25.1754				
EB1.25.1904.400 -1SPPN			RKS.061.25.1904				
EB1.50 S							
EB1.50.1900.400 -1SPPN		11-50 1900/2-06400					
EB1.50.2130.400-1SPPN		11-50 2130/2-06410					
EB1.50.2355.400 -1SPPN		11-50 2355/2-06420					
EB1.50.2645.400 -1SPPN		11-50 2645/2-06430					
EB1 STOCK							
EB1.20.0224.200-1STTN						VE030A00	
EB1.22.0225.400-1SPPN				E.1.032-400			
EB1.22.0228.200-1SPPN					E.318.22.00.D.1		
EB1.22.0308.200-1SPPN				E.1.040-200	E.403.22.00.D.1		
EB1.20.0344.200-1STTN							
EB1.25.0475.202-1SPPN				E.1.060-200	E.595.25.00.D.6	VE059A00/A10	
EB1.20.0662.200-1STTN						VE079A00	
EB1.22.0758.201-1SPPN				E.1.086-200*		VE086A00*	
EB1.25.0854.200-1SPPN				E.1.097-200		VE097A00*	
EB1.25.0856.200-1STPN						VE097A02	
EB1.25.1076.200-1SPPN				E.1.120-205			
EB1.25.1076.201-1STPN						2IE.120.00	
EB1.25.1525.200-1STPN				E.1.167-200			
ZB1.20 S							
ZB1.20.0314.200-1SPTN							
ZB1.20.0414.200-1SPTN	062.20.0414.500.01.1503	12-20 0411/1-02212	RKS.062.20.0414		I.486.20.00 B	2DI.048.00	VSI 20 0414 N
ZB1.20.0544.200-1SPTN	062.20.0544.500.01.1503	12-20 0541/1-02222	RKS.062.20.0544		I.616.20.00 B	2DI.061.00	VSI 20 0544 N
ZB1.20.0644.200-1SPTN	062.20.0644.500.01.1503	12-20 0641/1-02232	RKS.062.20.0644		I.716.20.00 B	2DI.071.00	VSI 20 0644 N
ZB1.20.0744.200-1SPTN	062.20.0744.500.01.1503	12-20 0741/1-02242	RKS.062.20.0744		I.816.20.00 B	2DI.081.00	VSI 20 0744 N
ZB1.20.0844.200-1SPTN	062.20.0844.500.01.1503	12-20 0841/1-02252	RKS.062.20.0844		I.916.20.00 B	2DI.091.00	VSI 20 0844 N
ZB1.20.0944.200-1SPTN	062.20.0944.500.01.1503	12-20 0941/1-02262	RKS.062.20.0944		I.1016.20.00 B	2DI.101.00	VSI 20 0944 N
ZB1.20.1094.200-1SPTN	062.20.1094.500.01.1503	12-20 1091/1-02272	RKS.062.20.1094		I.1166.20.00 B	2DI.116.00	VSI 20 1094 N

Código ISB ISB Code	ROTHERDE	IMO	SKF	MRI	TORRIANI	INA
ZB1.20 P						
ZB1.20.0314.201-2SPTN		12-20 0311/1-02203				
ZB1.20.0414.201-2SPTN	062.20.0414.575.01.1403	12-20 0411/1-02213				
ZB1.20.0544.201-2SPTN	062.20.0544.575.01.1403	12-20 0541/1-02223				
ZB1.20.0644.201-2SPTN	062.20.0644.575.01.1403	12-20 0641/1-02233				
ZB1.20.0744.201-2SPTN	062.20.0744.575.01.1403	12-20 0741/1-02243				
ZB1.20.0844.201-2SPTN	062.20.0844.575.01.1403	12-20 0841/1-02253				
ZB1.20.0944.201-2SPTN	062.20.0944.575.01.1403	12-20 0941/1-02263				
ZB1.20.1094.201-2SPTN	062.20.1094.575.01.1403	12-20 1091/1-02273				
ZB1.25 S						
ZB1.25.0455.200-1SPTN		12-25 0455/1-04210				
ZB1.25.0555.200-1SPTN		12-25 0555/1-04220				
ZB1.25.0655.200-1SPTN		12-25 0655/1-04230				
ZB1.25.0755.200-1SPTN		12-25 0755/1-04240				VSI 25 0755 N
ZB1.25.0855.200-1SPTN	062.25.0855.500.11.1503	12-25 0855/1-03210				VSI 25 0855 N
ZB1.25.0955.200-1SPTN	062.25.0955.500.11.1503	12-25 0955/1-03220				VSI 25 0955 N
ZB1.25.1055.200-1SPTN	062.25.1055.500.11.1503	12-25 1055/1-03230				VSI 25 1055 N
ZB1.25.1155.200-1SPTN	062.25.1155.500.11.1503	12-25 1155/1-03240				
ZB1.25.1255.200-1SPTN	062.25.1255.500.11.1503	12-25 1255/1-03250				
ZB1.25.1355.200-1SPTN	062.25.1355.500.11.1503	12-25 1355/1-03260				
ZB1.25.1455.200-1SPTN	062.25.1455.500.11.1503	12-25 1455/1-03270				
ZB1.25 P						
ZB1.25.0455.201-2SPTN						
ZB1.25.0555.201-2SPTN						
ZB1.25.0655.201-2SPTN						
ZB1.25.0755.201-2SPTN					I.855.25.00.B	VSI 25 0755 N ZT
ZB1.25.0855.201-2SPTN	062.25.0855.575.11.1403				I.955.25.00.B	VSI 25 0855 N ZT
ZB1.25.0955.201-2SPTN	062.25.0955.575.11.1403				I.1055.25.00.B	VSI 25 0955 N ZT
ZB1.25.1055.201-2SPTN	062.25.1055.575.11.1403				I.1155.25.00.B	VSI 25 1055 N ZT
ZB1.25.1155.201-2SPTN	062.25.1155.575.11.1403					
ZB1.25.1255.201-2SPTN	062.25.1255.575.11.1403					
ZB1.25.1355.201-2SPTN	062.25.1355.575.11.1403					
ZB1.25.1455.201-2SPTN	062.25.1455.575.11.1403					
ZB1.25 R						
ZB1.25.1204.400-1SPPN			RKS.062.25.1204			
ZB1.25.1314.400-1SPPN			RKS.062.25.1314			
ZB1.25.1424.400-1SPPN			RKS.062.25.1424			
ZB1.25.1534.400-1SPPN			RKS.062.25.1534			
ZB1.25.1644.400-1SPPN			RKS.062.25.1644			
ZB1.25.1754.400-1SPPN			RKS.062.25.1754			
ZB1.25.1904.400-1SPPN			RKS.062.25.1904			
ZB1.50 S						
ZB1.50.1800.400-1SPPN		12-50 1800/2-06500				
ZB1.50.2000.400-1SPPN		12-50 2000/2-06510				
ZB1.50.2240.400-1SPPN		12-50 2240/2-06520				
ZB1.50.2490.400-1SPPN		12-50 2490/2-06530				
ZB1.50.2800.400-1SPPN		12-50 2800/2-06540				
ZB1 STOCK						
ZB1.16.0260.400-1SPPN				I.1.032-400		
ZB1.20.0310.200-2SPTN						VI040A01
ZB1.16.0400.200-1RTTN				I.1.046-728*		

Nota: esta es una tabla de referencia. Se aconseja siempre de controlar la correspondencia con los dibujos o tablas. *Controlar pequeñas diferencias.
Note: this table is for reference use only. Please always check adaptability with drawings or tables comparison. *Check small differences.

Código ISB ISB Code	ROTHERDE	IMO	SKF	MRI	TORRIANI	RIMA	INA
ZB1.20.0465.200-1RPTN				I.1.054-730*			
ZB1.25.0488.200-2SPPN				I.1.057-201			
ZB1.20.0568.200-2RPPN				I.1.064-732			
ZB1.20.0605.200-1RTTN				I.1.069-733			
ZB1.25.0663.200-1SPPN				I.1.075-201			
ZB1.25.0663.201-1SPPN					I.750.25.00.D.1		
ZB1.25.0763.200-1SPPN				I.1.085-200			
ZB1.25.0762.200-1SPPN					I.850.25.00.D.1		
ZB1.25.0763.202-1RPTN				I.1.085-731			
ZB1.25.0860.200-1SPPN				I.1.095-201			
ZB1.25.0862.200-1SPPN					I.950.25.00.D.1		
ZB1.25.0862.201-1SPTN							
ZB1.28.1879.200-1SPPN							
NB1.20 S							
NB1.20.0314.200-1PPN		10-20 0311/0-02002					
NB1.20.0414.200-1PPN	060.20.0414.500.01.1503	10-20 0411/0-02012	RKS.060.20.0414	S.1.049-241	SD.486.20.00 B	2CS.048.00	VSU 20 0414
NB1.20.0544.200-1PPN	060.20.0544.500.01.1503	10-20 0541/0-02022	RKS.060.20.0544	S.1.062-241	SD.616.20.00 B	2CS.061.00	VSU 20 0544
NB1.20.0644.200-1PPN	060.20.0644.500.01.1503	10-20 0641/0-02032	RKS.060.20.0644		SD.716.20.00 B	2CS.071.00	VSU 20 0644
NB1.20.0744.200-1PPN	060.20.0744.500.01.1503	10-20 0741/0-02042	RKS.060.20.0744		SD.816.20.00 B	2CS.081.00	VSU 20 0744
NB1.20.0844.200-1PPN	060.20.0844.500.01.1503	10-20 0841/0-02052	RKS.060.20.0844		SD.916.20.00 B	2CS.091.00	VSU 20 0844
NB1.20.0944.200-1PPN	060.20.0944.500.01.1503	10-20 0941/0-02062	RKS.060.20.0944		SD.1016.20.00 B	2CS.101.00	VSU 20 0944
NB1.20.1094.200-1PPN	060.20.1094.500.01.1503	10-20 1091/0-02072	RKS.060.20.1094		SD.1166.20.00 B	2CS.116.00	VSU 20 1094
NB1.20 P							
NB1.20.0314.201-2PPN		10-20 0311/0-02003					
NB1.20.0414.201-2PPN	060.20.0414.575.01.1403	10-20 0411/0-02013					
NB1.20.0544.201-2PPN	060.20.0544.575.01.1403	10-20 0541/0-02023					
NB1.20.0644.201-2PPN	060.20.0644.575.01.1403	10-20 0641/0-02033					
NB1.20.0744.201-2PPN	060.20.0744.575.01.1403	10-20 0741/0-02043					
NB1.20.0844.201-2PPN	060.20.0844.575.01.1403	10-20 0841/0-02053					
NB1.20.0944.201-2PPN	060.20.0944.575.01.1403	10-20 0941/0-02063					
NB1.20.1094.201-2PPN	060.20.1094.575.01.1403	10-20 1091/0-02073					
NB1.25 S							
NB1.25.0455.200-1PPN		10-25 0455/0-04010					
NB1.25.0555.200-1PPN		10-25 0555/0-04020					
NB1.25.0655.200-1PPN		10-25 0655/0-04030					
NB1.25.0755.200-1PPN		10-25 0755/0-04040					VSU 25 0755
NB1.25.0855.200-1PPN	060.25.0855.500.11.1503	10-25 0855/0-03010					VSU 25 0855
NB1.25.0955.200-1PPN	060.25.0955.500.11.1503	10-25 0955/0-03020					VSU 25 0955
NB1.25.1055.200-1PPN	060.25.1055.500.11.1503	10-25 1055/0-03030					VSU 25 1055
NB1.25.1155.200-1PPN	060.25.1155.500.11.1503	10-25 1155/0-03040					
NB1.25.1255.200-1PPN	060.25.1255.500.11.1503	10-25 1255/0-03050					
NB1.25.1355.200-1PPN	060.25.1355.500.11.1503	10-25 1355/0-03060					
NB1.25.1455.200-1PPN	060.25.1455.500.11.1503	10-25 1455/0-03070					
NB1.25 P							
NB1.25.0755.201-2PPN							VSU 25 0755 ZT
NB1.25.0855.201-2PPN	060.25.0855.575.11.1403						VSU 25 0855 ZT
NB1.25.0955.201-2PPN	060.25.0955.575.11.1403						VSU 25 0955 ZT
NB1.25.1055.201-2PPN	060.25.1055.575.11.1403						VSU 25 1055 ZT
NB1.25.1155.201-2PPN	060.25.1155.575.11.1403						
NB1.25.1255.201-2PPN	060.25.1255.575.11.1403						
NB1.25.1355.201-2PPN	060.25.1355.575.11.1403						
NB1.25.1455.201-2PPN	060.25.1455.575.11.1403						

Código ISB ISB Code	ROTHE ERDE	IMO	SKF	MRI	TORRIANI	LEONESSA	INA
NB1.25 R							
NB1.25.1204.400-1PPN			RKS.060.25.1204				
NB1.25.1314.400-1PPN			RKS.060.25.1314				
NB1.25.1424.400-1PPN			RKS.060.25.1424				
NB1.25.1534.400-1PPN			RKS.060.25.1534				
NB1.25.1644.400-1PPN			RKS.060.25.1644				
NB1.25.1754.400-1PPN			RKS.060.25.1754				
NB1.25.1904.400-1PPN			RKS.060.25.1904				
NB1 STOCK							
NB1.14.0179.200-1PPN							VU 14 0179 (ZT)
NB1.14.0179.201-1PPN					SD.234.14.00.D.1		
NB1.20.0220.200-1PPN							VU 20 0220 (ZT)
NB1.20.0260.200-1PPN					SD.329.20.00.D.1	V032A02	
NB1.20.0260.201-1PPN				S.1.033-241			
NB1.20.0260.202-1PPN							VU 20 0260 (ZT)
NB1.22.0308.200-1PPN						VS040A00	
NB1.25.0308.200-1PPN				S.1.039-341			
NB1.25.0475.200-1PPN							

Código ISB ISB Code	MRI
EB2	
EB2.22.0307.200-1SPPN	E.2.043-201
EB2.22.0383.200-1SPPN	E.2.050-201
EB2.25.0475.200-1SPPN	E.2.060-300
EB2.25.0575.200-1SPPN	E.2.071-200
EB2.20.0752.200-1SPPN	E.2.086-206
EB2.25.0821.200-1SPPN	E.2.098-203
EB2.20.0968.200-1SPPN	E.2.108-200
EB2.25.1077.200-1SPPN	E.2.120-204
EB2.28.1215.200-1SPPN	E.2.138-306
EB2.22.0383.400-1SPPN	E.2.050-404
EB2.25.0475.400-1SPPN	E.2.062-402
EB2.25.0575.400-1SPPN	E.2.070-400
EB2.25.0980.400-1SPPN	E.2.114-300
EB2.25.0980.400-1RPPN	E.2.114-603
EB2.28.1117.400-1SPPN	E.2.129-300
EB2.28.1215.400-1SPPN	E.2.138-400
EB2.30.1249.400-1SPPN	E.2.148-403
EB2.35.1249.400-1SPPN	E.2.148-603**
EB2.30.1391.400-1SPPN	E.2.160-302
EB2.35.1402.400-1SPPN	E.2.160-400
EB2.25.1391.400-1SPPN	E.2.160-604**
EB2.35.1390.400-1SPPN	E.2.163-400
EB2.30.1578.400-1SPPN	E.2.180-400
EB2.35.1578.400-1SPPN	E.2.181-400

** Dientes no templados
** Gear not hardenend

Código ISB ISB Code	MRI
ZB2	
ZB2.22.0625.400-1SPPN	I.2.070-400
ZB2.22.0763.400-1SPPN	I.2.085-303
ZB2.20.0763.400-1RPPN	I.2.085-832
ZB2.22.0885.400-1SPPN	I.2.098-401
ZB2.20.0897.200-1SPPN	I.2.097-203
ZB2.25.0972.400-1SPPN	I.2.107-400
ZB2.22.1088.200-1SPPN	I.2.116-201
ZB2.22.1088.201-1SPPN	I.2.116-306
ZB2.22.1088.400-1SPPN	I.2.116-401
ZB2.25.1103.200-1SPPN	I.2.120-201
ZB2.25.1103.400-1SPPN	I.2.120-400
ZB2.25.1103.401-1SPPN	I.2.120-412
ZB2.30.1143.400-1SPPN	I.2.125-401
ZB2.28.1222.400-1SPPN	I.2.134-303/401
ZB2.28.1222.401-1SPPN	I.2.134-310
ZB2.30.1351.400-1SPPN	I.2.146-302/404
ZB2.30.1351.401-1SPPN	I.2.146-303/400
ZB2.30.1351.403-1SPPN	I.2.146-408
ZB2.40.1386.400-1SPPN	I.2.153-403
ZB2.40.1386.401-1SPPN	I.2.153-408
ZB2.30.1613.200-1SPPN	I.2.175-300
ZB2.30.1613.401-1SPPN	I.2.175-401
ZB2.45.1605.400-1SPPN	I.2.178-400
ZB2.45.1605.401-1SPPN	I.2.178-402
ZB2.35.1935.400-1SPPN	I.2.210-400
ZB2.35.2003.400-1SPPN	I.2.218-401

Nota: esta es una tabla de referencia. Se aconseja siempre de controlar la correspondencia con los dibujos o tablas. *Controlar pequeñas diferencias.
Note: this table is for reference use only. Please always check adaptability with drawings or tables comparison. *Check small differences.

Código ISB ISB Code	SKF	INA	ROLLIX
ER1.14 S			
ER1.14.0414.200-1STPN	RKS.161.14.0414		
ER1.14.0544.200-1STPN	RKS.161.14.0544		
ER1.14.0644.200-1STPN	RKS.161.14.0644		
ER1.14.0744.200-1STPN	RKS.161.14.0744		
ER1.14.0844.200-1STPN	RKS.161.14.0844		
ER1.14.0944.200-1STPN	RKS.161.14.0944		
ER1.14.1094.200-1STPN	RKS.161.14.1094		
ER1.14 PR			
ER1.14.0414.200-3STPN		XSA 14 0414	
ER1.14.0544.200-3STPN		XSA 14 0544	
ER1.14.0644.200-3STPN		XSA 14 0644	
ER1.14.0744.200-3STPN		XSA 14 0744	
ER1.14.0844.200-3STPN		XSA 14 0844	
ER1.14.0944.200-3STPN		XSA 14 0944	
ER1.14.1094.200-3STPN		XSA 14 1094	
ER1.16 S			
ER1.16.1204.400-1SPPN	RKS.161.16.1204		
ER1.16.1314.400-1SPPN	RKS.161.16.1314		
ER1.16.1424.400-1SPPN	RKS.161.16.1424		
ER1.16.1534.400-1SPPN	RKS.161.16.1534		
ER1.16.1644.400-1SPPN	RKS.161.16.1644		
ER1.16.1754.400-1SPPN	RKS.161.16.1754		
ER1.20.1904.400-1SPPN	RKS.161.20.1904		
ER1.20/30			
ER1.20.0307.400-1SPPN			06.0307.00
ER1.25.0400.400-1SPPN			06.0400.00
ER1.25.0475.400-1SPPN			06.0475.22
ER1.30.0508.400-1SPPN			06.0508.00
ER1.25.0574.400-1SPPN			06.0574.09
ER1.25.0675.400-1SPPN			06.0675.00
ER1.25.0734.400-1SPPN			06.0734.00
ER1.30.0823.400-1SPPN			06.0823.18
ER1.30.0980.400-1SPPN			06.0980.09
ER1.36/50			
ER1.36.1116.400-1SPPN			06.1116.00
ER1.36.1250.400-1SPPN			06.1250.21
ER1.45.1390.400-1SPPN			06.1390.03
ER1.45.1595.400-1SPPN			06.1595.04
ER1.45.1790.400-1SPPN			06.1790.09
ER1.50.2002.400-1SPPN			06.2002.00
ER1.50.2242.400-1SPPN			06.2242.00
ER1.50.2500.400-1SPPN			06.2500.01
ER1.50.2810.400-1SPPN			06.2810.09
ZR1.14 S			
ZR1.14.0414.200-1SPTN	RKS.162.14.0414		
ZR1.14.0544.200-1SPTN	RKS.162.14.0544		
ZR1.14.0644.200-1SPTN	RKS.162.14.0644		
ZR1.14.0744.200-1SPTN	RKS.162.14.0744		
ZR1.14.0844.200-1SPTN	RKS.162.14.0844		
ZR1.14.0944.200-1SPTN	RKS.162.14.0944		
ZR1.14.1094.200-1SPTN	RKS.162.14.1094		

Código ISB ISB Code	SKF	INA	ROLLIX
ZR1.14 PR			
ZR1.14.0414.200-3SPTN		XSI 14 0414	
ZR1.14.0544.200-3SPTN		XSI 14 0544	
ZR1.14.0644.200-3SPTN		XSI 14 0644	
ZR1.14.0744.200-3SPTN		XSI 14 0744	
ZR1.14.0844.200-3SPTN		XSI 14 0844	
ZR1.14.0944.200-3SPTN		XSI 14 0944	
ZR1.14.1094.200-3SPTN		XSI 14 1094	
ZR1.16 S			
ZR1.16.1204.400-1SPPN	RKS.162.16.1204		
ZR1.16.1314.400-1SPPN	RKS.162.16.1314		
ZR1.16.1424.400-1SPPN	RKS.162.16.1424		
ZR1.16.1534.400-1SPPN	RKS.162.16.1534		
ZR1.16.1644.400-1SPPN	RKS.162.16.1644		
ZR1.16.1754.400-1SPPN	RKS.162.16.1754		
ZR1.20.1904.400-1SPPN	RKS.162.20.1904		
ZR1.16/25			
ZR1.16.0380.400-1SPPN			07.0380.01
ZR1.20.0489.400-1SPPN			07.0489.11
ZR1.20.573.400-1SPPN			07.0573.00
ZR1.25.0673.400-1SPPN			07.0673.00
ZR1.25.0714.400-1SPPN			-
ZR1.25.0770.400-1SPPN			07.0770.00
ZR1.25.0849.400-1SPPN			07.0849.00
ZR1.25.0946.400-1SPPN			07.0946.05
ZR1.25.1050.400-1SPPN			-
ZR1.30/50			
ZR1.30.1140.400-1SPPN			07.1140.13
ZR1.36.1304.400-1SPPN			07.1304.04
ZR1.40.1385.400-1SPPN			07.1385.03
ZR1.45.1606.400-1SPPN			07.1606.00
ZR1.45.1830.400-1SPPN			07.1830.00
ZR1.50.1997.400-1SPPN			07.1997.04
ZR1.50.2400.400-1SPPN			07.2400.00
ZR1.50.2810.400-1SPPN			07.2810.09
NR1.14 S			
NR1.14.0414.200-1PPN	RKS.160.14.0414		
NR1.14.0544.200-1PPN	RKS.160.14.0544		
NR1.14.0644.200-1PPN	RKS.160.14.0644		
NR1.14.0744.200-1PPN	RKS.160.14.0744		
NR1.14.0844.200-1PPN	RKS.160.14.0844		
NR1.14.0944.200-1PPN	RKS.160.14.0944		
NR1.14.1094.200-1PPN	RKS.160.14.1094		
NR1.14 PR			
NR1.14.0414.200-3PPN		XSU 14 0414	
NR1.14.0544.200-3PPN		XSU 14 0544	
NR1.14.0644.200-3PPN		XSU 14 0644	
NR1.14.0744.200-3PPN		XSU 14 0744	
NR1.14.0844.200-3PPN		XSU 14 0844	
NR1.14.0944.200-3PPN		XSU 14 0944	
NR1.14.1094.200-3PPN		XSU 14 1094	

Código ISB ISB Code	IMO	SKF
NR1.16.1204.400-1PPN		RKS.160.16.1204
NR1.16.1314.400-1PPN		RKS.160.16.1314
NR1.16.1424.400-1PPN		RKS.160.16.1424
NR1.16.1534.400-1PPN		RKS.160.16.1534
NR1.16.1644.400-1PPN		RKS.160.16.1644
NR1.16.1754.400-1PPN		RKS.160.16.1754
NR1.20.1904.400-1PPN		RKS.160.20.1904
ER3.20/25		
ER3.20.1250.400-1SPPN	31-20 1250/2-06700	
ER3.20.1400.400-1SPPN	31-20 1400/2-06710	
ER3.20.1600.400-1SPPN	31-20 1600/2-06720	
ER3.20.1800.400-1SPPN	31-20 1800/2-06730	
ER3.20.2000.400-1SPPN	31-20 2000/2-06740	
ER3.25.1800.400-1SPPN	31-25 1800/2-06800	
ER3.25.2000.400-1SPPN	31-25 2000/2-06810	
ER3.25.2240.400-1SPPN	31-25 2240/2-06820	
ER3.25.2500.400-1SPPN	31-25 2500/2-06830	
ER3.25.2800.400-1SPPN	31-25 2800/2-06840	
ER3.32/40		
ER3.32.2240.400-1SPPN	31-32 2240/2-07300	
ER3.32.2500.400-1SPPN	31-32 2500/2-07310	
ER3.32.2800.400-1SPPN	31-32 2800/2-07320	
ER3.32.3150.400-1SPPN	31-32 3150/2-07330	
ER3.32.3550.400-1SPPN	31-32 3550/2-07340	
ER3.32.4000.400-1SPPN	31-32 4000/2-07350	
ER3.40.2800.400-1SPPN	31-40 2800/2-07420	
ER3.40.3150.400-1SPPN	31-40 3150/2-07430	
ER3.40.3550.400-1SPPN	31-40 3550/2-07440	
ER3.40.4000.400-1SPPN	31-40 4000/2-07450	
ER3.40.4500.400-1SPPN	31-40 4500/2-07460	
ZR3.20/25		
ZR3.20.1250.400-1SPPN	32-20 1250/2-06750	
ZR3.20.1400.400-1SPPN	32-20 1400/2-06760	
ZR3.20.1600.400-1SPPN	32-20 1600/2-06770	
ZR3.20.1800.400-1SPPN	32-20 1800/2-06780	
ZR3.20.2000.400-1SPPN	32-20 2000/2-06790	
ZR3.25.1800.400-1SPPN	32-25 1800/2-06850	
ZR3.25.2000.400-1SPPN	32-25 2000/2-06860	
ZR3.25.2240.400-1SPPN	32-25 2240/2-06870	
ZR3.25.2500.400-1SPPN	32-25 2500/2-06880	
ZR3.25.2800.400-1SPPN	32-25 2800/2-06890	
ZR3.32/40		
ZR3.32.2240.400-1SPPN	32-32 2240/2-07360	
ZR3.32.2500.400-1SPPN	32-32 2500/2-07370	
ZR3.32.2800.400-1SPPN	32-32 2800/2-07380	
ZR3.32.3150.400-1SPPN	32-32 3150/2-07390	
ZR3.32.3550.400-1SPPN	32-32 3550/2-07400	
ZR3.32.4000.400-1SPPN	32-32 4000/2-07410	
ZR3.40.2800.400-1SPPN	32-40 2800/2-07470	
ZR3.40.3150.400-1SPPN	32-40 3150/2-07480	
ZR3.40.3550.400-1SPPN	32-40 3550/2-07490	
ZR3.40.4000.400-1SPPN	32-40 4000/2-07500	
ZR3.40.4500.400-1SPPN	32-40 4500/2-07510	



Nota: esta es una tabla de referencia.
Se aconseja controlar la correspondencia.
Note: this table is for reference use only.
Please always check adaptability with drawings or tables comparison



Introducción

Los suministros de los productos presentes en este documento están regulados por las siguientes condiciones generales de venta. Se hará necesario un acuerdo previo escrito con el proveedor en para ulteriores y eventuales cláusulas y/o condiciones particulares requeridas por los clientes.

Se considerarán inaceptables todas las cláusulas y/o condiciones contractuales en contraste con lo expuesto en las presentes condiciones de venta.

1) Ofertas y órdenes

Las ofertas mantienen una validez de 30 días a contar desde la fecha de comunicación al cliente. Transcurrido dicho lapso sin haber recibido la orden, el proveedor tendrá la facultad de aceptar o rechazar la orden tardía. Todas las órdenes deberán indicar siempre la tipología del producto, la cantidad y la fecha de entrega requerida. El proveedor se reserva el derecho de suministrar eventualmente otros productos con las mismas características merceológicas que las solicitadas.

Las órdenes resultan vinculantes para el cliente, incluso cuando no están formuladas por escrito. El proveedor tendrá la misma obligación en el momento del envío de la confirmación de orden de compra (excluidas las excepciones a los puntos dos y cinco).

2) Precios

Los precios válidos de referencia son los indicados en la oferta y/o en la aceptación de la orden y se refieren sólo a productos estándares. Los precios relativos a tipologías especiales de producto y/o no estándares o bien bajo específicos requerimientos del cliente, se acordarán, en cada específica instancia, entre las partes. El proveedor se reserva el derecho, por exigencias productivas y/o de suministro, de suministrar una cantidad de producto con una variación equivalente al $\pm 15\%$ respecto a la cantidad acordada con el cliente. Si durante el suministro, se verifican aumentos, causados por variaciones como por ejemplo: aumento de las materias primas, del coste de la mano de obra, del coste de los transportes, de los impuestos y tributos, como así también otros aumentos que impliquen aumentos de los costes del producto para el proveedor, este último podrá, a su entero juicio, adecuar los precios, comunicando dicho aumento al cliente. Las cotizaciones de los productos, se considerarán siempre franco la sede del proveedor, estando excluidos siempre de dicha cotización el embalaje y el IVA.

3) Entrega

La entrega se considerará finalizada y ultimada en el momento en el cual los productos se pongan a disposición del cliente en el banco, en la sede del proveedor o en el momento de la entrega al transportista. Si el cliente no ha dado precisas instrucciones sobre las modalidades de expedición de los productos o no los ha retirado tempestivamente, el proveedor podrá conservarlos en su propia sede; los riesgos y peligros y los respectivos gastos estarán a cargo del cliente y el proveedor no tendrá responsabilidad alguna en lo que se refiere a la conservación o expedición de los productos con medios propios o mediante transportistas.

4) Plazos de entrega

Los plazos de entrega indicados por el proveedor son indicativos y no tienen un carácter esencial ni perentorio. Su incumplimiento no podrá ser considerado como motivo de rescisión del contrato ni dará derecho a ningún tipo de indemnización. El proveedor respetará los plazos acordados en la medida de lo posible, ya que la entrega depende también de terceros. El proveedor podrá rescindir el contrato y/o modificar los plazos de entrega, sin que esto constituya motivo de resarcimiento ni pago de indemnizaciones por eventuales daños que sufrieran los clientes, en los siguientes casos:

- I. Incumplimiento de los pagos y/o deudas por parte del cliente.
- II. Dificultades en fase de suministro de los productos.
- III. Modificaciones a las condiciones contractuales después de la recepción de la orden.
- IV. Casos de fuerza mayor, no imputables a la voluntad del proveedor, como por ejemplo, huelgas de cualquier tipo, calamidades naturales, epidemias, revueltas, tumultos, guerras, bloqueos aduaneros, que puedan afectar al proveedor mismo o a sus fuentes de suministro.
- V. Inexactitudes o retardos por parte del cliente en la confirmación del orden. Por los hechos expuestos en los puntos I-III-V el proveedor podrá siempre exigir una indemnización al cliente.

Introduction

The supply of the products covered by this document is governed by the following general conditions of sale. Any additional clauses and/or special conditions requested by Customers shall only be valid in case of prior written agreement with the Supplier.

All contract clauses and/or conditions in conflict with the terms set out below shall be considered unacceptable.

1) Offers and orders

Offers are valid for 30 days from the date of communication to the Customer. If no order is received within this period, the Supplier shall have the option of accepting or rejecting late orders, at its own discretion. All orders must always state the type of product, the quantity and the delivery date required. The Supplier reserves the right to supply different products with the same characteristics as those ordered.

Orders are binding on the Customer even if not in writing. Orders shall also be binding on the Supplier once the confirmation of order has been dispatched (with the exceptions in points two and five below).

2) Prices

The valid reference prices are those stated in the offer and/or the order acceptance, and refer to standard products only. The prices relating to special and/or nonstandard product types, or to specific requests from the Customer, shall be agreed between the parties for each order on a one-off basis. Depending on production and/or procurement requirements, the Supplier reserves the right to supply a quantity of product with variation of $\pm 15\%$ from the quantity agreed with the Customer. Over a series of shipments, if increases occur due to variations such as increases in raw material costs, in the cost of labour, freight costs, taxes and duties, or any other increases which lead to increases in the cost of the product for the Supplier, the latter may adjust the prices accordingly, at its own absolute discretion, informing the Customer of the amount of any such increase. Quotations for products are ex-works Supplier's factory, not including packaging or VAT.

3) Delivery

Delivery is considered to have taken place when the products are placed on the Customer's disposal on the counter on the Supplier's premises, or on consignment to the carrier/ forwarding agent. If the Customer has not given clear instructions concerning the procedures for shipment of the products, or has not arranged for their prompt collection, the Supplier may store them on its own premises, at the Customer's risk and expense, without any responsibility for their conservation, or may ship them using its own vehicles or carriers of its choice.

4) Delivery terms

The delivery terms stated by the Supplier are guideline and not binding. In no case shall failure to meet them constitute grounds for termination of the contract and/or for compensation for any damage of any kind. Delivery terms shall be complied with as far as possible, since delivery depends on third parties over which the Supplier has no control. The Supplier may terminate the contract and/or modify the delivery terms, without this constituting grounds for compensation and/or payment of damages for any costs or losses incurred by the Customer, in the following cases:

- I. Failure to meet payment terms and/or outstanding debts on the part of the Customer.
- II. Difficulty in procurement of the products.
- III. Modifications of the contract conditions after receipt of the order.
- IV. Circumstances of force majeure, beyond the Supplier's control, such as, for example, strikes of various kinds, natural disasters, epidemics, uprisings, riots, wars or customs blockades which may affect the Supplier itself or its sources of supply.
- V. Inaccuracies or delays on the part of the Customer in confirming the order. In the circumstances listed in points I-III-V, the Supplier may request compensation from the Customer.

5) Expediciones

Las expediciones estarán siempre a cargo de los clientes, como así también los riesgos y peligros inherentes a la misma, incluso en los casos de expediciones franco domicilio del cliente. En el caso de eventuales adulteraciones o falta de productos imputables al transportista, el cliente tendrá la obligación de presentar un reclamo directamente al transportista. El proveedor podrá aceptar reclamos por eventuales diferencias, cualitativas y cuantitativas de los productos sólo si el cliente efectúa dichos reclamos por escrito dentro de los ocho días, a contar desde la fecha de recepción de los productos, so pena de caducidad de todo derecho de reclamo más allá de dicho plazo. Si el cliente no da instrucciones detalladas, no podrá imputarse ninguna responsabilidad al proveedor por la elección de los medios de transporte, en lo que se refiere a las tarifas aplicadas por los transportistas. Además, si no subsiste un acuerdo entre las partes, los gastos de expedición estarán siempre a cargo del cliente. En el caso que los gastos de transporte estén a cargo del proveedor, incluso parcialmente, el mismo podrá elegir los medios de transporte más económicos, a su entero juicio. Ulteriores recargos y costes adicionales de transporte estarán exclusivamente a cargo del cliente. En caso de eventuales errores de entrega causados por el cliente, con la consecuente devolución de los productos, el proveedor tendrá el derecho de cargar al cliente los eventuales gastos de expedición y el 15% del precio de los productos.

6) Pagos

El cliente no podrá suspender ni retardar los pagos de las mercancías por ningún motivo. Dichos pagos se deberán efectuar al domicilio del proveedor, como se indica en los documentos que acompañan la expedición de los productos. No se considerarán válidos los pagos efectuados en lugares diversos, salvo en los casos en los cuales existan acuerdos previos con el proveedor en este sentido.

Una vez transcurridos los plazos indicados, el proveedor tendrá derecho a exigir el pago, además de la suma correspondiente al precio de la mercancía, de los intereses de demora, según Euribor más un 3%, con el derecho además de iniciar las pertinentes acciones legales contra el cliente moroso.

El proveedor tiene la facultad de suspender transitoriamente la fabricación o el suministro de los productos aún en fase de orden; además podrá anular la parte residual de la orden misma, comunicándolo al cliente, el cual no tendrá derecho a ningún tipo de indemnización.

El proveedor tendrá el derecho de exigir el pago de las sumas adeudadas por las entregas ya efectuadas. Eventuales reclamos inherentes a productos en curso de fabricación, listos para su expedición o ya en poder del cliente, no liberarán al cliente de sus obligaciones, debiendo el mismo por lo tanto efectuar los pagos acordados y en las fechas estipuladas.

7) Garantía

La garantía tiene una validez de un año a contar desde la fecha de la entrega de los productos; la misma se circunscribe exclusivamente a la reparación o sustitución gratuita de las piezas reconocidas como no conformes respecto a las especificaciones expuestas en los catálogos técnicos.

La responsabilidad de la garantía del proveedor decae para los productos que han sufrido adulteraciones, esfuerzos impropios de servicio, lubricaciones o reparaciones erróneas o bien errores en fase de montaje, como así también en todos los casos de problemas vinculados a una utilización impropia por parte del cliente y por lo tanto no imputables al proveedor.

El cliente además tiene la obligación de avisar al proveedor sobre eventuales defectos, vicios o no conformidades de los productos dentro de los ocho días de la recepción de los mismos (en forma escrita), so pena, en caso contrario, de caducidad de la garantía. No se aceptarán reclamos una vez transcurridos dichos plazos.

Los reclamos no justifican la anulación ni la reducción de las órdenes del cliente, ni dan lugar a indemnizaciones y/o resarcimientos a cargo del proveedor. No se aceptan devoluciones de productos sin una previa autorización del proveedor. No se aceptan devoluciones de suministros, en el caso de productos que se envíen no íntegros o adulterados o bien contruados, elaborados y/o modificados por parte del cliente. El material no conforme se deberá enviar, previa autorización del proveedor, libre de todo gasto (franco destino). En el documento de envío se deberán exponer los datos del DDT o la respectiva factura de venta (Fecha y n° - obligatorio por ley). El proveedor no se asume ninguna responsabilidad por incidentes que puedan verificarse en la utilización de sus productos.

5) Shipments

Shipments are always made on the Customer's behalf and therefore at its risk, even in case of delivery "freight prepaid". In case of tampering or missing items for which the carrier/forwarding agent is specifically to blame, the Customer shall be responsible for placing a claim directly with the carrier/forwarding agent. The Supplier will only be able to accept claims for any differences in the quality or quantity of the products if submitted by the Customer, in writing within eight days after the date of receipt of the products; otherwise, all claims shall become null and void. In the absence of detailed instructions from the Customer, the Supplier shall not be responsible for the choice of means of transport or for the rates charged by the carriers/forwarding agents. Moreover, in the absence of agreement between the parties, the shipment expenses shall be payable by the Customer. If even just a part of the freight costs is to be met by the Supplier, the latter shall be permitted to make use of the most economical means of transport, at its own absolute discretion. Any additional freight costs and/or charges shall be solely for the Customer's account. For errors in delivery caused by the Customer which result in return of the products, the Supplier shall be entitled to charge the Customer the shipment expenses, if due, plus 15% of the price of the products.

6) Payment

The Customer shall not be permitted to suspend or delay payments for goods for any reason, and payments must be made to the Supplier's domicile, as stated in the documents which accompany the shipment of the products. Payments made to other places shall not be considered valid unless agreed in advance with the Supplier.

Once the specified payment terms have passed, the Supplier shall be entitled to payment, not only of the capital sum due for the price of the goods, but also of interest at the Euribor rate increased by 3%, and retains the right to take legal action against any Customer late with payments.

The Supplier shall be entitled to temporarily suspend the manufacture or supply of any products still on order; it may also cancel the remainder of the order, informing the Customer, which shall not be entitled to compensation of any kind. The Supplier shall be entitled to obtain payment of the sums due to it for the deliveries already made. In case of any disputes concerning products being manufactured, ready for shipment or already in the Customer's possession, the latter shall not be released from its obligations and must pay the amounts due to the Supplier at the date set.

7) Warranty

The warranty is valid for one year from the date of delivery of the products; it is limited solely to the repair or replacement, free of charge, of pieces acknowledged not to comply with the specifications stated in the technical catalogues.

The Supplier's warranty ceases to apply to all products which have been tampered with, operated with overloads, improperly lubricated or repaired, or incorrectly assembled; in other words, for all problems caused by improper use by the Customer, for which the Supplier is not responsible.

The Customer is also obliged to inform the Supplier about any defects, faults or nonconformity of the products within eight days after the date of receipt of the same (in writing); otherwise, the warranty shall become null and void. No claims shall be accepted once the above terms have expired.

Claims shall not constitute grounds for the cancellation or reduction of orders on the part of the Customer, or the payment of damages and/or compensation on the part of the Supplier. No returns of products are accepted unless authorised in advance.

No returns are accepted of products which are not intact, have been tampered with, or have been specifically built, processed and/or modified for the Customer. Nonconforming material must be returned, further to the Supplier's authorisation, with all expenses paid (freight prepaid). The return document must contain the details of the original transport document or invoice (date and number - compulsory by law).

The Supplier does not accept any responsibility for accidents occurring during the use of its products.

8) Ofertas y órdenes

El proveedor, cuando acepte órdenes para productos especiales o realizados según particulares requerimientos del cliente, deberá siempre recibir un diseño técnico detallado antes de iniciar la producción de los mismos. Después de haber aceptado la orden y de haber recibido el diseño técnico, el proveedor enviará al cliente una muestra del producto. Una vez que el cliente ha recibido y examinado la muestra deberá enviar una confirmación escrita al proveedor para que el mismo ultime el suministro. En el caso que el cliente, por motivos no imputables al proveedor rechace en modo total o parcial el suministro, el proveedor podrá ejercitar el derecho de cobrar los gastos por la realización de las muestras de productos, como así también por la pérdida de beneficios y por eventuales perjuicios sufridos, en los casos de productos no comercializables. El proveedor se encargará del retiro y la sustitución del material no conforme, cuando el cliente demuestre en modo evidente que las características del producto suministrado no corresponden a las de las muestras entregadas. De todos modos el proveedor no aceptará ninguna ulterior responsabilidad ni el cliente tendrá derecho a indemnizaciones de ningún tipo.

9) Materiales

Los materiales utilizados para la fabricación de los productos, presentes en este catálogo, pueden sufrir actualizaciones exclusivamente mejorativas, dentro de su propia categoría. El cliente no podrá por lo tanto reclamar por estas modificaciones ante el Proveedor.

10) Validez y derogaciones de las Condiciones Generales de Venta

Cualquier tipo de derogación o modificación de las condiciones generales de venta aquí expuestas, se deberá acordar entre las partes en forma escrita.

11) Domicilio del Cliente

El domicilio del Cliente será aquel en el cual el cliente tiene su sede legal, a menos que el mismo comunique por escrito otro domicilio. El proveedor por lo tanto efectuará todas las comunicaciones y envíos de productos a dicha sede.

12) Tribunal competente

Para toda eventual controversia entre las partes resultará competente el tribunal donde se encuentra la sede legal del proveedor.

8) Special and/or custom-made products

If the Supplier accepts orders for special products or those made to the Customer's own technical specifications, it must always receive a detailed technical drawing before proceeding with production. After accepting the order and further to consignment of the technical drawing, the Supplier shall send the Customer a sample lot of the product. After viewing the sample lot, the Customer shall send the Supplier written confirmation for production of the entire ordered amount. If, due to circumstances beyond the Supplier's control, the Customer refuses delivery of all or part of the goods, the Supplier shall be entitled to reimbursement of the expenses for production of the sample lot, and for compensation for loss of earnings and for any damages incurred, since these products are not marketable.

The Supplier shall collect and replace non-conforming material if the Customer clearly demonstrates that the characteristics of the product supplied differ from those of the samples consigned, without any liability on the part of the Supplier and with waiver on the part of the Customer of any request for compensation on any grounds.

9) Materials

The materials used to manufacture the products featured in this catalogue may be updated exclusively for improvement purposes within their range, therefore the Customer is not entitled to have recourse to these upgrades to lodge any claim with the Supplier.

10) Validity and waivers of the General Conditions of Sale

Any waivers or modifications of the aforesaid general conditions of sale must be agreed between the parties in writing.

11) Customer's Domicile

The Customer shall be domiciled in the place where it has its registered office, unless otherwise notified in writing. The Supplier shall therefore send all communications and shipments of products to the relevant address.

12) Legal jurisdiction

The law court of the Supplier's registered office shall have jurisdiction over all disputes of any kind.



© Copyright ISB®

Está prohibida la reproducción, incluso parcial, del contenido de este Catálogo Técnico. No se acepta ningún tipo de responsabilidad en caso de errores u omisiones. Las medidas no son vinculantes. Marca registrada Italia-EU.

The reproduction, even partial, of the contained concerning this Technical Catalogue, is forbidden. Liability for possible errors and/or omissions are not accepted. Sizes are not binding.™ Registered in Italy-EU.



Política ambiental

El presente **Catálogo Técnico ISB®** ha sido realizado con **material ecológico certificado FSC**. El proceso productivo del papel se lleva a cabo respetando las normativas vigentes. **DS/EN ISO 14001 e ISO 9001:2000**. La plastificación de la portada se realizó utilizando material biodegradable; las tintas para la impresión son de base vegetal. Por favor continúe Usted también con su compromiso por la protección del medio ambiente.

Environmental policy

This ISB® Technical Catalogue has been produced with 100% ecological material certified FSC. Manufacturing process follows the regulations in force: DS/EN ISO 14001 and ISO 9001:2000. Plasticization of the cover page has been achieved using biodegradable materials, inks used are vegetable based. Please continue your actions in order to protect the environment and recycle properly.



CORONAS GIRATORIAS
SLEWING BEARINGS

01.07.2012 ©Copyright 



79991021

